

PARTS MANUAL

MAGNUM

MODEL	HP	ENGINE SPECS
-------	----	--------------

M18	18	24500-24682
-----	----	-------------

M20	20	49500-49620
-----	----	-------------

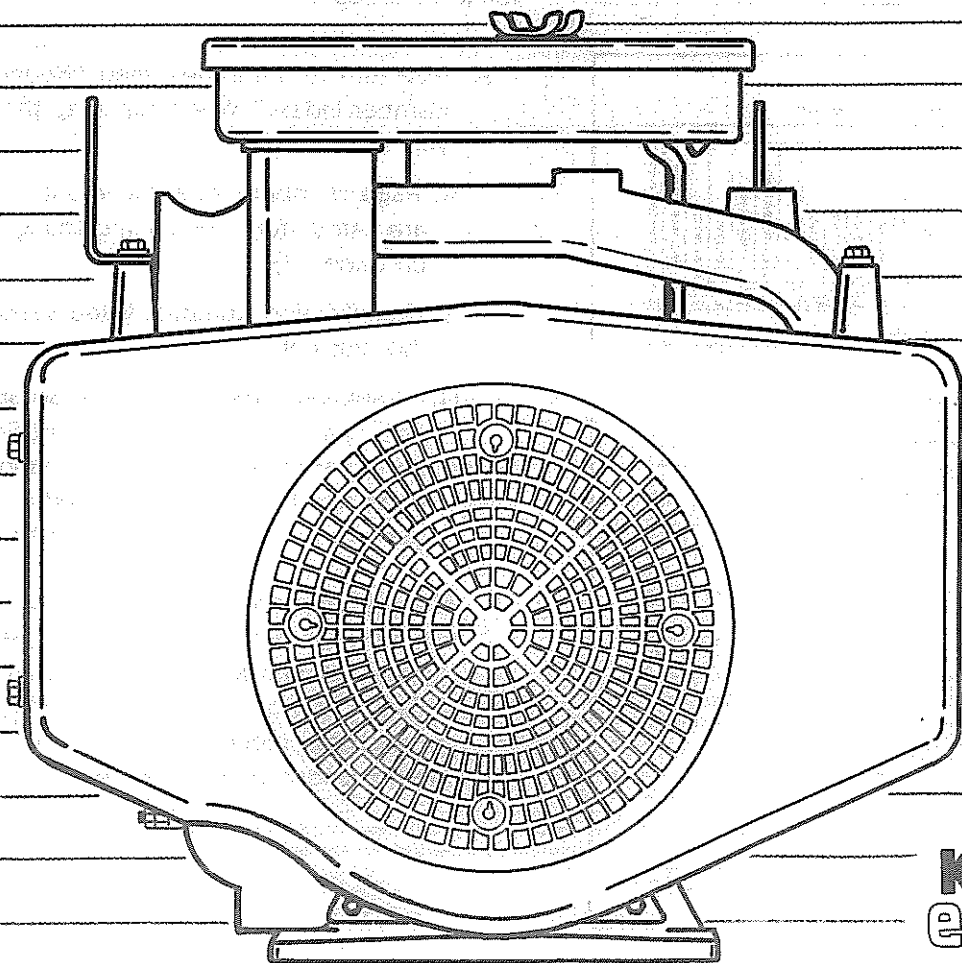

KOHLER
engines

HOW TO FIND PART NUMBERS

- Turn the page of the parts manual to the "Composite Exploded View." Notice the boxed groupings identified by their function along with a corresponding number. The group function and number applies to all engine models.

For example:

Function (Group Description)	Group Number
Air Intake	1
Baffles & Shroud	2
Breather & Vent	3
Camshaft & Valves	4
Carburetor	5
Electric Starter	11
Ignition	18
etc.	

Remember the Group Number in which you located your part. (If the part you need is not illustrated, locate a major engine function related to your part and use that Group Number.)

Example: You need an air cleaner cover for M18, specification 24501. The air cleaner cover is found in Group 1.

- Now turn to the pages titled "Specification Number Index." When scanning these pages, you'll notice;

- Page Numbers indexing where Group Parts are listed (for Group 1 the listing begins on page 13);
- Specification Numbers listed vertically down the first column;
- "Variation" Numbers in the Group Number columns. (These numbers specifically identify a particular group (combination) of parts used in a particular model - and are used to locate the specific part numbers.)

☞ Locate your specification number in the first column. Go across the page to the Group Number column for your part. Jot down the Variation Number found in that column. For our example (spec. 24501), the variation number under Group 1 is "14".

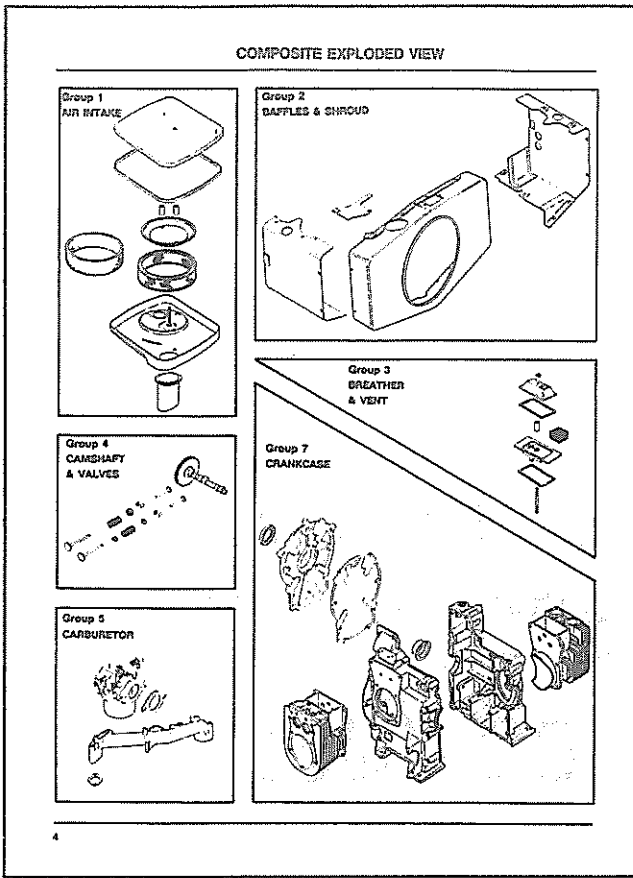

SPECIFICATION NUMBER INDEX M18

Group Title & Number	Variation Number																															
	1	2	3	4	5	7	8	9	10	11	12	13	14	15	16	17	18	19	20	21	22	23	24	25	26	27	28	29	30	31	32	
Page No.	13	15	18	20	21	23	29	31	32	33	35	37	39	41	43	45	48	49	50	51	53	54										
Grid No.	A13	B1	B4	B5	B10	B14	C3	C5	C4	C6	C8	C10	C12	C14	D5	D6	D7	D9	D10	D11												
24509	14	77	4	39	62	100	80	11	13	9	300	56	5	21	29	-	-	-	-	-	-	-	-	-	-	-	-	-	-	-	-	
24521	14	77	4	39	62	100	80	11	13	9	300	56	5	21	29	-	-	-	-	-	-	-	-	-	-	-	-	-	-	-	-	
24522	14	77	4	39	62	107	66	11	13	9	300	56	5	23	29	-	-	-	-	-	-	-	-	-	-	-	-	-	-	-	-	
24523	14	77	4	39	62	100	80	11	13	9	31	56	5	21	29	-	-	-	-	-	-	-	-	-	-	-	-	-	-	-	-	
24524	14	77	4	39	62	100	80	11	13	9	18	52	5	22	29	-	-	-	-	-	-	-	-	-	-	-	-	-	-	-	-	
24525	14	77	4	39	62	107	102	11	13	9	15	55	5	22	16	6	-	-	-	-	-	-	-	-	-	-	-	-	-	-	-	
24526	14	102	4	39	62	102	102	14	0	15	57	52	22	16	16	-	-	-	-	-	-	-	-	-	-	-	-	-	-	-	-	
24527	14	102	4	39	62	102	102	14	0	15	57	52	22	16	16	-	-	-	-	-	-	-	-	-	-	-	-	-	-	-	-	
24528	13	79	4	39	62	102	102	14	0	15	57	52	22	16	16	-	-	-	-	-	-	-	-	-	-	-	-	-	-	-	-	
24529	29	61	3	23	29	29	29	29	29	29	29	29	29	29	29	-	-	-	-	-	-	-	-	-	-	-	-	-	-	-	-	
24510	33	62	3	23	29	29	29	29	29	29	29	29	29	29	29	-	-	-	-	-	-	-	-	-	-	-	-	-	-	-	-	
24511	34	63	3	23	29	29	29	29	29	29	29	29	29	29	29	-	-	-	-	-	-	-	-	-	-	-	-	-	-	-	-	
24512	300	300	3	23	29	29	29	29	29	29	29	29	29	29	29	-	-	-	-	-	-	-	-	-	-	-	-	-	-	-	-	
24513	37	78	3	23	29	102	61	14	15	10	14	80	6	21	45	-	-	-	-	-	-	-	-	-	-	-	-	-	-	-	-	
24514	43	85	3	23	31	102	60	14	14	8	34	58	2	21	40	-	-	-	-	-	-	-	-	-	-	-	-	-	-	-	-	
24515	13	79	3	29	13	105	80	11	14	0	201	56	5	21	43	-	-	-	-	-	-	-	-	-	-	-	-	-	-	-	-	
24519	14	88	4	39	62	102	63	11	13	9	7	59	19	21	31	-	-	-	-	-	-	-	-	-	-	-	-	-	-	-	-	
24521	35	77	4	39	62	102	63	11	13	9	34	69	5	21	31	-	-	-	-	-	-	-	-	-	-	-	-	-	-	-	-	
24522	10	79	3	23	15	176	99	11	14	0	34	56	6	400	31	-	-	-	-	-	-	-	-	-	-	-	-	-	-	-	-	
24523	14	77	4	39	13	102	80	31	13	9	24	55	5	21	39	-	-	-	-	-	-	-	-	-	-	-	-	-	-	-	-	
24524	14	60	4	39	61	100	141	11	13	9	7	200	36	21	29	-	-	-	-	-	-	-	-	-	-	-	-	-	-	-	-	
24525	13	84	3	29	12	105	80	14	13	9	7	59	19	21	31	-	-	-	-	-	-	-	-	-	-	-	-	-	-	-	-	
24526	34	73	3	29	29	100	80	14	13	9	302	56	5	45	30	-	-	-	-	-	-	-	-	-	-	-	-	-	-	-	-	
24529	13	110	3	17	19	118	114	11	14	0	304	201	5	21	29	-	-	-	-	-	-	-	-	-	-	-	-	-	-	-	-	
24528	14	60	4	39	62	102	103	25	13	9	400	52	201	21	29	-	-	-	-	-	-	-	-	-	-	-	-	-	-	-	-	
24529	22	85	3	23	25	112	114	11	13	9	35	59	5	21	29	-	-	-	-	-	-	-	-	-	-	-	-	-	-	-	-	
24530	42	112	4	33	25	122	100	11	13	9	31	55	5	21	39	-	-	-	-	-	-	-	-	-	-	-	-	-	-	-	-	
24533	14	77	4	39	62	102	102	14	0	15	57	52	22	16	16	-	-	-	-	-	-	-	-	-	-	-	-	-	-	-	-	
24540	14	77	4	39	62	102	102	14	0	15	57	52	22	16	16	-	-	-	-	-	-	-	-	-	-	-	-	-	-	-	-	
24541	13	110	3	23	13	102	80	11	14	0	69	69	10	21	29	-	-	-	-	-	-	-	-	-	-	-	-	-	-	-	-	
24542	14	77	4	39	13	100	80	11	13	9	6	58	5	21	29	-	-	-	-	-	-	-	-	-	-	-	-	-	-	-	-	
24543	14	77	4	39	13	100	80	11	13	9	0	0	56	5	22	18	8	-	-	-	-	-	-	-	-	-	-	-	-	-	-	
24544	14	102	4	39	45	104	110	11	13	9	15	58	5	21	45	-	-	-	-	-	-	-	-	-	-	-	-	-	-	-	-	
24545	14	113	4	39	25	100	80	11	13	9	21	56	5	21	42	-	-	-	-	-	-	-	-	-	-	-	-	-	-	-	-	
24546	14	112	4	39	25	100	80	11	13	9	21	56	5	21	42	-	-	-	-	-	-	-	-	-	-	-	-	-	-	-	-	
24547	14	112	4	39	25	100	80	11	13	9	21	56	5	21	42	-	-	-	-	-	-	-	-	-	-	-	-	-	-	-	-	
24548	14	112	4	39	25	100	80	11	13	9	21	56	5	21	42	-	-	-	-	-	-	-	-	-	-	-	-	-	-	-	-	
24549	204	319	4	39	13	100	80	11	13	9	18	56	301	21	29	-	-	-	-	-	-	-	-	-	-	-	-	-	-	-	-	
24550	27	72	4	39	12	121	60	11	13	9	40	58	5	17	31	-	-	-	-	-	-	-	-	-	-	-	-	-	-	-	-	
24553	13	73	3	29	13	100	80	11	14	0	21	55	5	21	34	-	-	-	-	-	-	-	-	-	-	-	-	-	-	-	-	
24554	14	84	4	39	13	102	102	11	13	9	21	59	302	21	29	-	-	-	-	-	-	-	-	-	-	-	-	-	-	-	-	
24555	14	102	4	39	43	116	80	31	14	9	13	59	9	24	29	-	-	-	-	-	-	-	-	-	-	-	-	-	-	-	-	

6 Consult your Kohler engine parts supplier for any specifications not listed. For Short Blocks, and Replacement Engines refer to Section Guide TP-2000-C.

HOW TO FIND PART NUMBERS

M10 & M20

Index Number	Description	Part Number	Index Number	Description	Part Number
1	Nut, wing 1/4"-28	X-276-7	4	Seal, element cover (1)	231922
1	Nut, wing 1/4"-28 (1)	X-276-7	4	Seal, element cover (2)	41022 02
2	Cover, air cleaner-square	52 082 02	5	Cover, air cleaner element	52 082 02
3	Seal, air cleaner	52 082 01	6	Pre-cleaner	52 083 01
4	Seal, element cover	47 043 01	7	Element, air cleaner	52 083 01

2 Cover, air cleaner-square
 14, 31, 35, 37, 42, 51, 60, 302, 303, 304, 305, 306
52 082 02

3. Go to the page for your Group (page 13) and look at the illustrations to find the one most similar to the original part.

A. Each part in the illustration is identified with an index number or letter. Use that identifier to locate the part description in the listing.

B. Find your "Variation Number", from Step 2, immediately below the description.

C. The correct part number will be in the column to the right of your variation number.

For our example, the air cleaner cover that looks like the original is index number 2. Looking in the listing next to index 2, we find our Variation Number (14), is shown, so the correct part number is 52 082 02.

Special Features

Near the end of the Parts Manual Binder is a separate section devoted to repair options for major damage. "Selection Guides" for each model engine give several different methods of repairing Kohler Engines . . . with the choice dependent on shop facilities, costs, and allowable downtime of the engine and/or equipment.

Selection guides are easy references for determining part numbers of Replacement Engines or Short Blocks. They also list part numbers of crankshafts installed in original engines.

Here is what you'll find:

- Engine model is identified on each page for easy reference;
- Bold column heads identify the various re-power options for every engine spec;
- All crankshaft changes required for Replacement Engines are flagged with "Yes;"
- Replacement Engines and Short Blocks.

M10, M20

There are several methods of repowering M10, M20 engines to consider—with the choice depending on your shop facilities, repair costs, and allowable downtime of the engine.

- Engine Replacement:** When decision is to replace, use a Kohler Replacement Engine—No modifications required.
- Short Block Replacement:** When engine including the crankshaft is extensively damaged or worn internally.
- Complete Overhaul:** Re-bore cylinder and grind crankshaft, using appropriate oversize and/or undersize replacement parts.

This Selection Guide provides an easy reference for determining the part number of the Replacement Engine or Short Block required for the repair method selected. It also lists the part number of the crankshaft installed in the original engine.

Locate the engine specification number in the index below. Select the part number of the repair method listed in the adjacent columns.

M10 ENGINE SPECIFICATIONS							
Engine Spec No.	Replacement Engine	Original Engine Crankshaft No.	Replac. Short Block	Engine Spec No.	Replacement Engine	Original Engine Crankshaft No.	Replac. Short Block
24500 ¹	24500 ¹	52 014 03	52 522 09	24545	---	52 014 00	52 522 72
24501 ¹	24501 ¹	52 014 03	52 522 09	24546	---	52 014 03	52 522 09
24502 ¹	24502 ¹	52 014 00	52 522 70	24548	---	52 014 06	52 522 74
24503 ¹	24503 ¹	52 014 03	52 522 09	24550	---	52 014 03	52 522 09
24504 ¹	24504 ¹	52 014 00	52 522 09	24552	---	52 014 00	52 522 70
24505 ¹	24505 ¹	52 014 70	52 522 14	24553	---	52 014 03	52 522 09
24506	24506	52 014 00	52 522 71	24554	24500	52 014 70	52 522 14
24507	---	52 014 03	52 522 09	24555	---	52 014 05	52 522 09
24508	24508	52 014 03	52 522 09	24557	---	52 014 03	52 522 09
24509	---	52 014 03	52 522 09	24558	---	52 014 00	52 522 70
24510	---	52 014 06	52 522 73	24559	---	52 014 05	52 522 09
24511	24510	52 014 03	52 522 09	24561	---	52 014 03	52 522 09
24512	---	52 014 06	52 522 74	24562	---	52 014 03	52 522 09
24513	---	52 014 06	52 522 74	24563	---	52 014 06	52 522 74
24514	---	52 014 03	52 522 09	24564	---	52 014 06	52 522 24
24515	---	52 014 00	52 522 09	24565	---	52 014 03	52 522 09
24516	24515	52 014 03	52 522 09	24566	24555	52 014 03	52 522 09
24517	---	52 014 70	52 522 14	24567	---	52 014 03	52 522 09
24518	24506	52 014 00	52 522 70	24568	---	52 014 02	52 522 09
24519	---	52 014 03	52 522 09	24569	---	52 014 03	52 522 09
24520	---	52 014 70	52 522 14	24570	---	52 014 09	52 522 16
24521	---	52 014 13	52 522 01	24571	---	52 014 03	52 522 09
24522	---	52 014 03	52 522 09	24572	---	52 014 04	52 522 11
24523	---	52 014 05	52 522 09	24573	---	52 014 05	52 522 09
24524	---	52 014 03	52 522 09	24574	---	52 014 05	52 522 09
24525	---	52 014 05	52 522 09	24575	---	52 014 05	52 522 09
24526	---	52 014 03	52 522 09	24576	---	52 014 03	52 522 09
24527	---	52 014 05	52 522 09	24577	---	52 014 03	52 522 09
24528	24532	52 014 70	52 522 14	24578	---	52 014 09	52 522 16
24529	---	52 014 05	52 522 73	24579	---	52 014 03	52 522 09
24530	---	52 014 06	52 522 09	24580	---	52 014 04	52 522 11
24531	---	52 014 03	52 522 09	24581	---	52 014 04	52 522 11
24532	---	52 014 03	52 522 09	24582	---	52 014 04	52 522 11
24533	---	52 014 05	52 522 09	24583	---	52 014 04	52 522 11
24534	---	52 014 05	52 522 09	24584	---	52 014 04	52 522 11
24535	---	52 014 03	52 522 09	24585	---	52 014 04	52 522 11
24536	---	52 014 03	52 522 09	24586	---	52 014 04	52 522 11
24537	---	52 014 03	52 522 09	24587	---	52 014 04	52 522 11
24538	---	52 014 03	52 522 09	24588	---	52 014 04	52 522 11
24539	---	52 014 03	52 522 09	24589	---	52 014 04	52 522 11
24540	---	52 014 03	52 522 09	24590	---	52 014 04	52 522 11
24541	---	52 014 03	52 522 09	24591	---	52 014 04	52 522 11
24542	---	52 014 03	52 522 09	24592	---	52 014 04	52 522 11
24543	24531 ¹	52 014 03	52 522 09	24593	---	52 014 04	52 522 11
24544	24533	52 014 03	52 522 09	24594	---	52 014 04	52 522 11

¹Basic Engine
²Governor gear 52 542 03 must be ordered with Short Block. Installation Instruction (77-303-A) will be included with Short Block.

All Short Blocks include an overhaul gasket set.

COMPOSITE EXPLODED VIEW

**Group 1
AIR INTAKE**

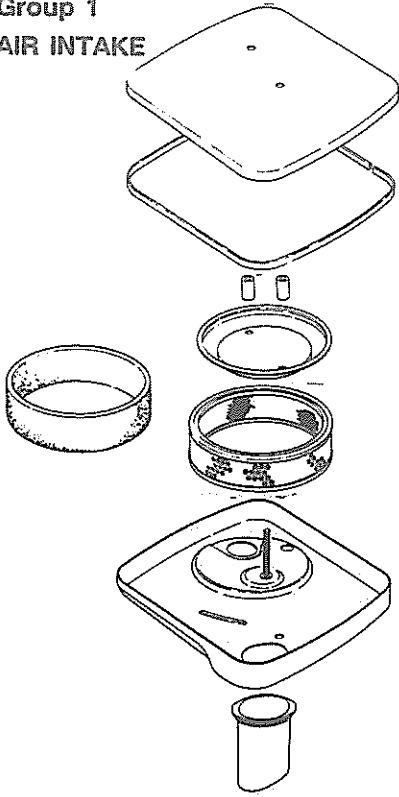

**Group 2
BAFFLES & SHROUD**

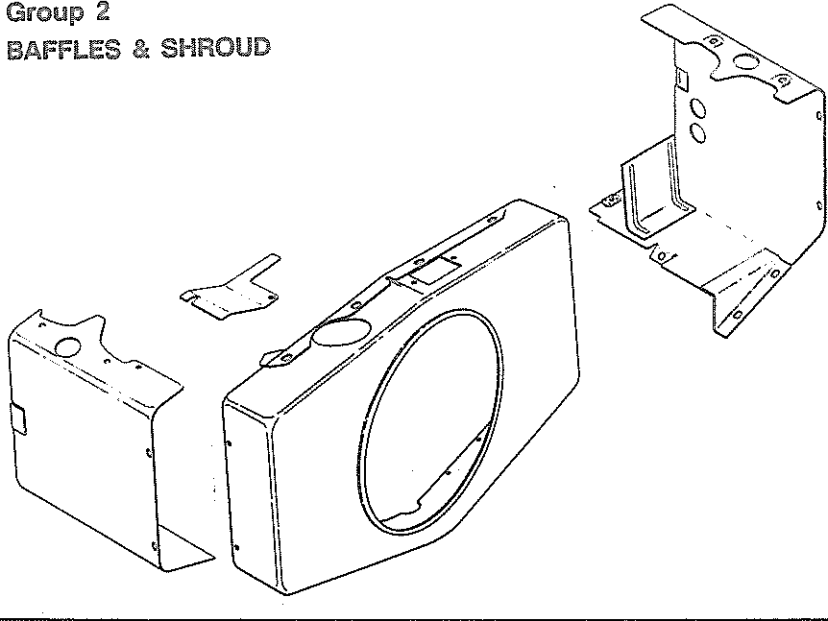

**Group 3
BREATHER
& VENT**

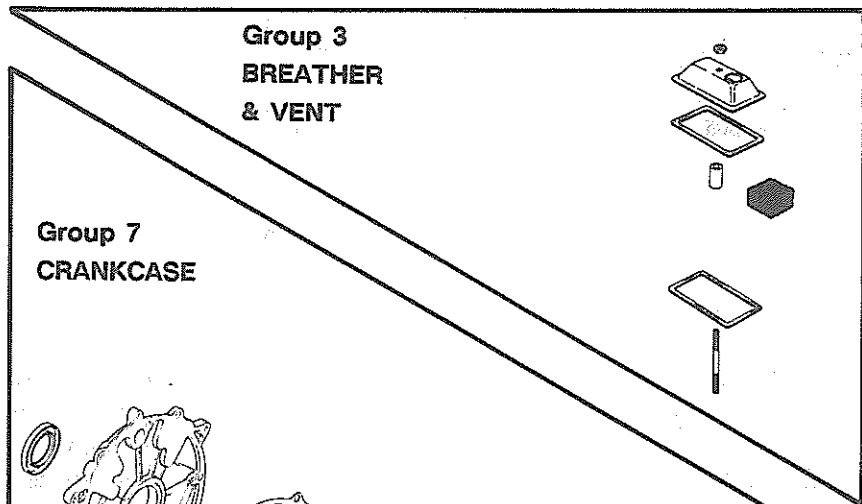

**Group 4
CAMSHAFT
& VALVES**

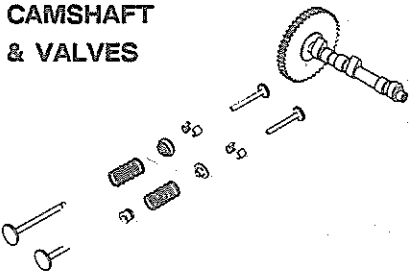

**Group 5
CARBURETOR**

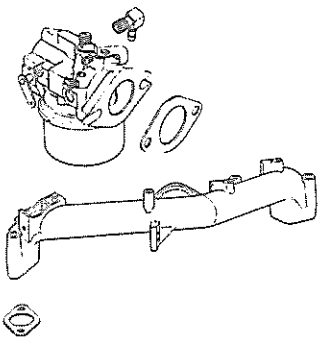

**Group 7
CRANKCASE**

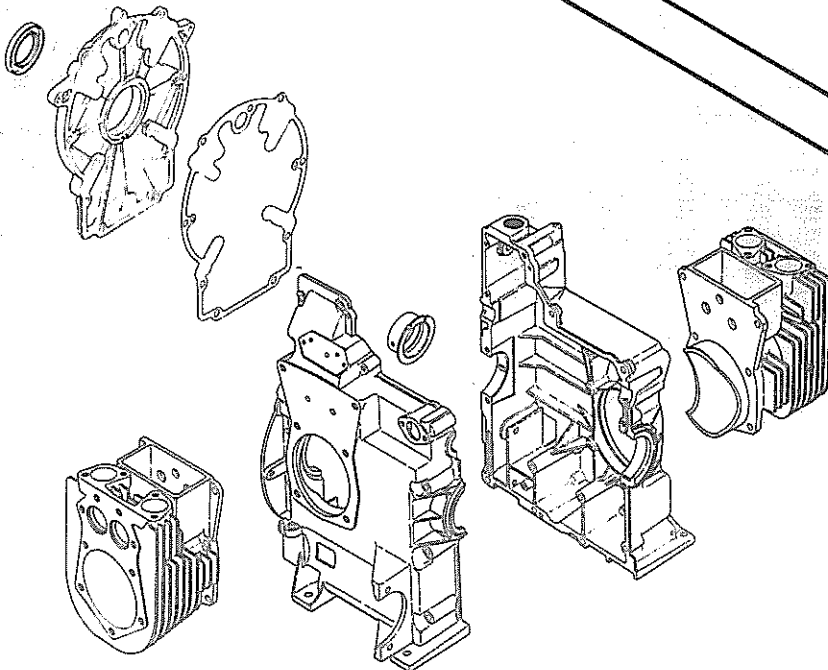

COMPOSITE EXPLODED VIEW

Group 8
CRANKSHAFT

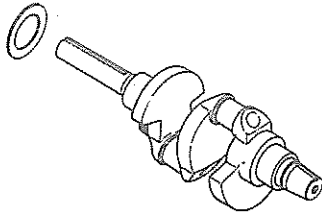

Group 9
CYLINDER HEAD

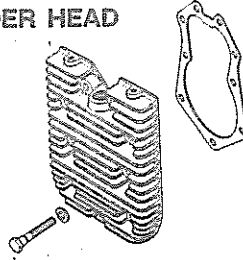

Group 10
DIPSTICK



Group 11
ELECTRIC START

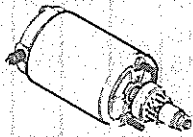

Group 12
EXHAUST

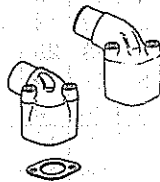

Group 13
FLYWHEEL

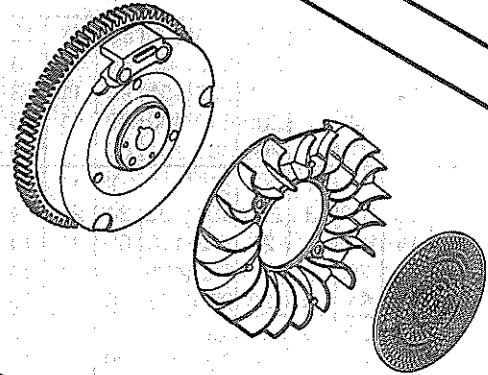

Group 14
FUEL PUMP

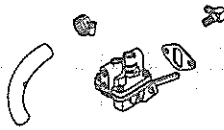

Group 17
GOVERNOR

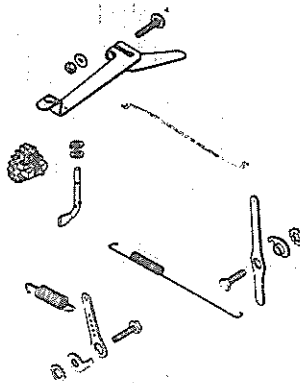

Group 22
PISTON & ROD

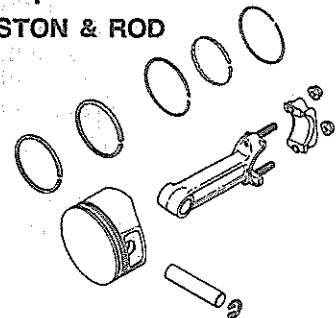

Group 18
IGNITION

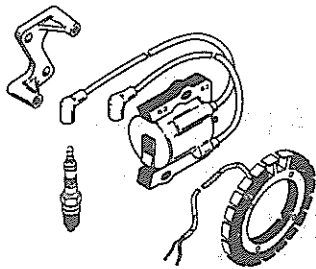

Group 25
OIL PUMP

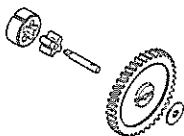

Group 29
OIL FILTER

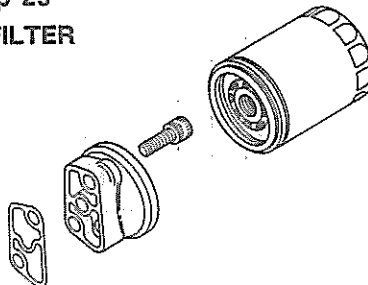

Group 32
OIL LEVEL CUTOUT

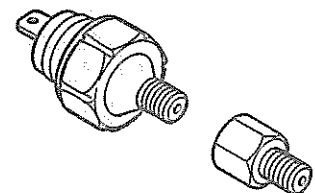

Specification Number Index

Group Title & Number	Air Intake	Baffles & Shroud	Breather & Vent	Camshaft & Valves	Carburetor	Crankcase	Crankshaft	Cylinder Head	Dipstick	Electric Start	Exhaust	Flywheel	Fuel Pump	Governor	Ignition	Instrument Panel	Piston & Rod	Oil Pump	Oil Filter	High Temp. Cutout	Oil Pressure Cutout				
	1	2	3	4	5	7	8	9	10	11	12	13	14	17	18	19	22	25	29	31	32				
Page No.	12	14	18	19	20	25	29	31	32	33	35	37	39	41	43	46	49	50	51	54	54				
Grid No.	A11	A14	B4	B5	B6	C2	C7	C9	C10	C11	C13	D1	D3	D5	D7	D10	D13	D14	E1	E7	E7				

Spec. No.
Variation No.

24500	14	77	4	200	300	400	80	11	13	9	300	56	5	21	29	-	14	4	2	-	15					
24501	14	77	4	200	300	400	80	11	13	9	300	56	5	22	18	6	14	4	2	-	15					
24502	14	77	4	200	300	401	99	11	13	9	300	56	5	23	29	-	14	4	2	-	15					
24503	14	94	4	200	300	400	80	11	13	9	21	56	5	21	29	-	14	4	2	-	15					
24504	14	77	4	200	300	160	80	11	13	9	15	56	5	22	18	6	14	4	2	-	15					
24505	14	77	4	200	300	167	103	11	13	9	15	56	5	22	18	6	14	4	2	-	15					
24506	13	100	3	200	301	402	84	26	14	9	8	57	22	26	16	-	14	4	7	-	6					
24507	14	102	4	28	302	116	80	11	14	9	15	56	9	24	46	-	14	4	2	-	15					
24508	13	79	3	200	303	400	80	11	14	9	303	56	6	10	29	-	14	4	4	-	15					
24509	29	81	3	28	306	403	80	11	13	9	7	58	5	6	31	-	14	4	4	-	8					
24510	33	82	3	28	30	118	114	11	13	9	25	58	6	24	33	-	14	4	4	-	8					
24511	34	83	3	28	306	403	80	11	13	9	301	58	5	21	31	-	14	4	4	-	8					
24512	300	308	3	28	303	403	84	11	14	9	20	303	5	21	31	-	14	4	4	-	300					
24513	27	79	3	200	306	165	84	11	13	10	14	60	6	21	46	-	14	4	12	-	15					
24514	43	86	3	202	31	404	80	14	13	8	34	56	2	40	30	-	14	4	2	1	8					
24515	13	79	3	200	303	405	80	11	14	9	301	56	300	21	46	-	14	4	2	-	15					
24519	14	98	4	200	300	400	83	11	13	9	7	58	37	21	23	-	14	4	4	-	15					
24521	35	77	4	200	304	117	103	11	13	9	34	69	5	37	31	-	14	4	2	-	8					
24522	13	79	3	200	303	406	99	11	14	9	34	56	6	400	31	-	14	4	2	-	15					
24523	14	77	4	200	303	400	80	11	13	9	24	56	5	21	29	-	14	4	2	-	15					
24524	14	98	4	200	305	400	141	11	13	9	7	300	36	21	27	-	14	4	4	-	13					
24525	13	84	3	200	303	405	80	26	14	9	7	58	19	21	29	-	14	4	4	-	15					
24526	34	79	3	200	306	408	80	14	13	8	302	56	6	40	30	-	14	4	2	1	8					
24529	13	110	3	17	303	118	114	11	14	8	304	301	5	21	29	-	14	4	2	-	15					
24532	14	401	4	200	300	408	103	30	13	9	400	65	301	21	29	302	-	14	4	301	-	26				
24536	32	82	3	28	30	118	114	11	13	9	25	58	6	24	33	-	14	4	4	-	8					
24538	42	112	4	200	307	407	80	11	13	9	21	56	2	21	29	-	14	4	3	-	15					
24539	14	77	4	200	300	178	83	23	13	9	15	65	5	21	29	-	14	4	2	-	5					
24540	14	77	4	200	303	175	117	11	13	8	27	56	301	21	27	303	-	14	4	2	-	5				
24541	13	110	3	200	303	405	85	11	14	8	40	63	10	21	29	-	14	4	2	-	15					
24542	14	77	4	200	303	400	80	11	13	9	6	56	5	21	29	-	14	4	2	-	15					
24543	14	77	4	200	303	400	80	11	13	8	300	56	5	22	18	8	14	4	2	-	20					
24544	14	102	4	200	302	164	80	11	14	9	15	56	11	24	46	-	14	4	4	-	15					
24545	14	113	4	200	300	409	118	11	13	9	34	67	302	21	31	42	-	14	4	2	-	8				
24546	14	112	4	200	26	400	80	11	13	9	21	56	2	21	27	-	14	4	3	-	15					
24548	27	79	3	200	306	405	84	11	13	10	14	60	6	21	46	-	14	4	12	-	15					
24550	304	310	4	200	300	400	80	11	13	10	16	56	301	21	29	-	14	4	4	-	15					
24552	37	77	4	28	27	121	99	11	13	9	40	56	5	17	18	11	14	4	2	-	15					
24553	13	79	3	200	303	400	80	11	14	9	24	56	5	21	34	310	-	14	4	2	-	13				
24554	14	94	4	200	303	400	103	11	13	9	31	58	303	21	29	-	14	4	9	-	15					
24555	14	102	4	28	302	116	80	11	14	9	15	56	9	24	29	-	14	4	2	-	5					
24557	14	94	4	200	300	400	80	11	13	8	7	56	5	21	27	-	14	4	3	-	5					
24558	14	77	4	200	300	401	99	11	13	9	300	56	5	23	18	16	14	4	2	-	5					
24560	32	79	3	200	29	178	83	11	14	9	305	56	5	22	18	9	14	4	2	-	5					
24561	14	313	4	200	308	160	80	11	13	9	307	56	15	21	29	-	14	4	2	-	301					

Specification Number Index

Group Title & Number	Air Intake	Baffles & Shroud	Breather & Vent	Camshaft & Valves	Carburetor	Crankcase	Crankshaft	Cylinder Head	Dipstick	Electric Start	Exhaust	Flywheel	Fuel Pump	Governor	Ignition	Instrument Panel	Piston & Rod	Oil Pump	Oil Filter	High Temp. Cutout	Oil Pressure Cutout				
	1	2	3	4	5	7	8	9	10	11	12	13	14	17	18	19	22	25	29	31	32				
Page No.	12	14	18	19	20	25	29	31	32	33	35	37	39	41	43	46	49	50	51	54	54				
Grid No.	A11	A14	B4	B5	B6	C2	C7	C9	C10	C11	C13	D1	D3	D5	D7	D10	D13	D14	E1	E7	E7				

Spec. No.
Variation No.

24562	14	77	4	200	309	160	80	11	13	9	40	56	5	22	18	9	14	4	2	-	5				
24563	54	131	3	200	41	165	84	11	14	9	41	304	36	31	49	-	14	4	11	-	11				
24564	14	98	4	28	309	117	84	11	13	9	56	301	6	21	300	-	14	4	4	-	15				
24565	14	77	4	28	309	112	80	11	13	9	39	56	5	21	29	-	14	4	2	-	15				
24566	34	83	3	200	45	165	80	11	13	9	301	58	5	31	51	-	14	4	4	-	8				
24567	14	77	4	200	308	179	126	11	13	9	6	56	5	300	29	-	14	4	2	-	15				
24568	13	141	3	200	313	165	80	14	14	9	7	71	19	21	33	-	14	4	2	1	8				
24569	13	79	3	200	44	179	121	11	14	9	39	56	16	34	29	-	14	4	2	-	15				
24570	14	77	4	200	309	160	80	11	13	9	40	56	5	22	18	6	14	4	2	-	15				
24571	34	84	3	28	29	117	80	11	13	9	7	58	5	21	31	-	14	4	4	-	8				
24573	48	130	3	200	29	144	85	11	13	9	402	69	17	21	53	-	14	4	4	-	15				
24574	35	79	4	200	314	160	80	11	13	9	34	56	5	31	54	-	14	4	2	-	15				
24575	50	79	10	200	309	160	80	11	13	9	39	56	15	30	29	311	14	4	2	-	15				
24576	14	77	4	200	309	160	80	18	13	9	39	56	5	21	29	-	14	4	2	1	5				
24577	14	77	4	200	315	160	80	11	13	9	309	56	36	401	400	-	14	4	2	-	15				
24578	14	77	4	200	309	179	121	11	13	9	59	56	5	32	18	11	14	4	2	-	15				
24579	14	77	4	200	309	160	80	11	13	9	39	56	5	22	18	24	14	4	2	-	20				
24581	14	77	4	200	309	165	85	11	13	9	48	56	39	22	18	6	14	4	2	-	15				
24582	14	77	4	200	308	165	85	11	13	9	39	56	22	22	18	6	14	4	2	-	15				
24583	14	77	4	200	309	160	85	11	13	9	40	56	15	22	18	6	14	4	2	-	15				
24585	48	79	3	200	310	207	85	11	13	9	34	69	30	21	58	-	14	4	2	-	6				
24586	14	77	4	200	309	179	126	11	13	9	6	56	5	21	29	-	14	4	2	-	15				
24587	14	77	4	200	309	160	80	11	13	9	24	56	5	21	29	-	14	4	2	-	15				
24588	52	133	3	200	311	164	80	11	14	9	15	56	34	24	46	-	14	4	2	-	15				
24589	52	133	3	200	311	164	80	11	14	9	15	56	11	24	46	-	14	4	4	-	15				
24590	52	133	3	200	311	164	80	11	14	9	15	56	9	24	29	-	14	4	2	-	5				
24591	13	79	3	200	44	160	80	11	14	9	19	56	16	34	29	-	14	4	2	-	15				
24592	35	135	4	200	51	160	80	11	13	9	34	56	5	31	301	-	14	4	2	-	5				
24593	34	79	3	200	309	160	80	11	14	9	24	67	5	21	57	306	14	4	2	-	5				
24594	34	83	3	200	316	165	80	26	13	9	301	58	5	31	51	-	14	4	2	-	8				
24595	14	77	4	200	308	179	121	11	14	9	40	56	302	34	18	16	14	4	2	-	5				
24597	34	141	3	200	310	165	80	11	13	9	7	58	51	21	31	-	14	4	2	-	8				
24598	14	143	4	200	308	165	84	11	13	14	56	302	6	21	300	-	14	4	4	-	15				
24599	54	141	3	200	41	165	84	11	14	9	41	304	5	31	49	-	14	4	2	-	11				
24600	306	311	4	200	68	179	121	11	13	9	39	56	18	34	77	26	14	4	2	-	15				
24601	14	77	4	201	308	167	103	11	13	9	300	300	5	22	18	6	14	4	2	-	15				
24602	14	312	4	201	308	165	80	11	14	9	302	67	5	21	46	-	14	4	2	-	15				
24603	13	79	3	201	317	179	121	11	14	9	39	56	16	34	27	-	14	4	2	-	303				
24605	14	77	4	201	62	160	80	11	13	9	300	56	5	22	18	6	14	4	2	-	15				
24606	14	77	4	201	309	160	80	11	13	9	24	56	5	22	18	307	14	4	2	-	15				
24608	14	149	4	201	308	410	103	30	13	8	31	58	303	21	29	-	14	4	2	-	15				
24610	13	79	3	201	68	160	80	11	14	9	59	56	16	34	29	-	14	4	2	-	5				
24611	14	77	4	201	62	167	133	11	13	9	300	300	5	22	18	6	14	4	2	-	15				
24612	14	77	4	201	62	160	80	11	13	9	39	56	5	22	18	9	14	4	2	-	15				
24614	14	77	4	201	62	160	80	11	13	9	42	56	5	21	29	26	14	4	2	-	15				

Specification Number Index

Group Title & Number	Air Intake	Baffles & Shroud	Breather & Vent	Camshaft & Valves	Carburetor	Crankcase	Crankshaft	Cylinder Head	Dipstick	Electric Start	Exhaust	Flywheel	Fuel Pump	Governor	Ignition	Instrument Panel	Piston & Rod	Oil Pump	Oil Filter	High Temp. Cutout	Oil Pressure Cutout				
	1	2	3	4	5	7	8	9	10	11	12	13	14	17	18	19	22	25	29	31	32				
Page No.	12	14	18	19	20	25	29	31	32	33	35	37	39	41	43	46	49	50	51	54	54				
Grid No.	A11	A14	B4	B5	B6	C2	C7	C9	C10	C11	C13	D1	D3	D5	D7	D10	D13	D14	E1	E7	E7				

Spec. No.	Variation No.																								
24615	34	141	3	201	71	160	85	30	13	8	18	74	21	21	46	-	14	4	4	-	15				
24616	58	153	3	201	62	165	80	11	13	9	50	67	22	21	31	-	14	4	12	-	8				
24617	14	77	4	201	62	165	84	11	13	9	310	56	5	21	31	-	14	4	2	-	21				
24618	14	77	4	201	62	160	80	11	13	9	7	76	5	21	29	303	14	4	2	-	5				
24619	35	135	4	201	51	160	80	11	13	9	34	65	5	31	44	312	14	4	2	-	15				
24620	301	130	3	201	88	207	85	11	13	9	34	69	30	21	53	-	14	4	4	-	15				
24621	14	77	4	201	62	180	103	11	13	9	15	56	5	22	18	6	14	4	2	-	15				
24622	13	141	3	201	13	165	80	14	14	8	7	71	19	21	33	-	14	4	2	1	8				
24623	305	309	4	201	62	160	80	11	13	9	25	56	5	22	18	30	14	4	2	-	15				
24624	14	77	4	201	62	167	134	11	13	9	300	300	36	22	18	6	14	4	2	-	15				
24625	13	79	3	201	44	179	121	11	14	9	59	56	16	34	27	-	14	4	2	-	305				
24626	14	77	4	201	312	180	80	11	13	9	39	56	301	22	18	400	14	4	2	-	8				
24627	14	77	4	201	312	165	80	11	13	9	311	56	22	21	18	31	14	4	2	-	15				
24628	305	311	4	201	62	160	80	11	13	9	15	56	5	22	34	32	14	4	2	-	304				
24629	14	77	4	201	61	160	80	11	13	9	312	56	5	21	73	309	14	4	2	-	15				
24630	14	152	4	201	51	179	121	11	13	9	15	65	5	31	44	-	14	4	2	-	15				
24631	304	304	4	201	319	183	127	26	13	14	24	77	5	31	82	-	14	4	2	-	302				
24632	14	77	4	201	312	160	80	11	13	9	15	56	15	22	18	6	14	4	2	-	15				
24633	52	133	3	201	43	164	80	11	14	9	15	56	11	24	46	-	14	4	4	-	5				
24634	13	79	3	29	78	157	136	11	14	9	34	56	6	33	76	-	14	4	2	-	15				
24635	13	79	3	29	78	157	136	11	14	9	34	56	6	33	76	-	14	4	4	-	15				
24636	14	94	4	201	320	179	126	23	13	11	21	67	5	31	76	-	14	4	3	-	8				
24637	13	86	3	201	68	183	126	11	14	9	15	56	2	42	27	-	14	4	2	-	15				
24638	14	77	4	201	62	179	126	11	13	9	24	56	5	22	18	6	14	4	2	-	15				
24639	48	162	3	201	71	207	85	26	13	9	18	69	30	21	58	-	14	4	2	-	15				
24640	14	77	4	201	62	160	103	11	13	9	300	56	5	22	18	9	14	4	2	-	5				
24641	14	77	4	201	62	180	80	11	13	9	300	56	5	22	18	6	14	4	2	-	15				
24642	34	79	3	201	71	160	80	14	13	8	34	56	6	40	30	-	14	4	2	1	8				
24644	48	141	3	29	88	207	85	11	13	9	18	69	30	21	58	-	14	4	2	-	6				
24645	14	77	4	29	62	160	80	11	13	9	300	56	5	22	18	9	14	4	2	-	5				
24646	13	176	3	29	337	162	84	26	14	9	8	57	400	49	123	-	14	4	16	-	6				
24647	13	176	3	29	62	162	84	26	14	9	8	57	52	26	16	-	14	4	16	-	6				
24648	48	79	3	29	71	207	85	11	13	9	34	69	30	21	58	-	14	4	2	-	6				
24649	14	77	4	29	13	160	80	11	13	9	24	56	31	21	29	306	14	4	2	-	15				
24650	14	156	4	29	43	411	138	11	13	14	72	75	5	24	69	-	14	4	2	-	8				
24651	304	77	4	29	62	179	121	11	13	9	306	56	5	21	29	309	14	4	300	-	15				
24652	14	77	4	29	318	160	80	11	13	9	300	56	5	22	81	6	14	4	2	-	15				
24653	14	77	4	29	312	165	80	11	13	9	48	56	22	22	81	6	14	4	2	-	15				
24654	32	166	3	29	62	160	80	11	14	9	29	56	5	22	18	37	14	4	13	-	5				
24655	14	98	4	29	79	162	83	11	13	9	7	58	7	31	84	-	14	4	4	-	15				
24656	14	77	4	29	79	165	80	11	13	9	313	56	5	31	82	-	14	4	2	-	15				
24657	34	141	3	29	71	160	85	30	13	8	18	74	21	21	46	-	14	4	2	-	15				
24658	14	149	4	29	61	160	141	11	13	9	7	300	5	21	27	-	14	4	2	-	13				
24659	14	171	4	29	79	160	80	30	13	9	67	56	5	47	87	9	14	4	2	-	5				
24660	14	77	4	29	62	165	80	11	13	9	23	56	5	22	18	6	14	4	2	-	15				

Specification Number Index

Group Title & Number	Air Intake	Baffles & Shroud	Breather & Vent	Camshaft & Valves	Carburetor	Crankcase	Crankshaft	Cylinder Head	Dipstick	Electric Start	Exhaust	Flywheel	Fuel Pump	Governor	Ignition	Instrument Panel	Piston & Rod	Oil Pump	Oil Filter	High Temp. Cutout	Oil Pressure Cutout				
	1	2	3	4	5	7	8	9	10	11	12	13	14	17	18	19	22	25	29	31	32				
Page No.	12	14	18	19	20	25	29	31	32	33	35	37	39	41	43	46	49	50	51	54	54				
Grid No.	A11	A14	B4	B5	B6	C2	C7	C9	C10	C11	C13	D1	D3	D5	D7	D10	D13	D14	E1	E7	E7				

Spec. No.

Variation No.

24661	14	77	4	29	62	165	103	11	13	9	34	78	5	37	31	-	14	4	2	-	8				
24662	14	156	4	29	62	160	80	11	13	14	302	75	5	21	27	304	14	4	2	-	15				
24663	32	166	3	29	62	160	80	11	14	9	302	56	5	22	18	37	14	4	13	-	5				
24664	14	77	4	29	79	160	80	11	13	9	15	56	5	47	34	43	14	4	2	-	15				
24665	63	141	3	29	88	207	85	11	13	9	70	69	17	21	53	-	14	4	2	-	15				
24666	48	141	3	29	88	207	85	26	13	9	70	69	30	21	58	-	14	4	2	-	6				
24668	14	178	4	29	43	165	143	26	13	14	21	82	53	24	46	-	14	4	2	-	15				
24669	-	-	12	34	82	204	87	31	25	1	15	81	2	-	83	-	14	4	18	-	13				
24670	14	178	4	29	43	165	143	28	13	14	21	82	53	24	46	-	14	4	2	-	15				
24671	14	77	4	29	62	206	145	11	13	9	300	56	5	22	18	9	14	4	2	-	5				
24672	14	77	4	29	321	179	121	11	13	9	15	56	5	22	18	28	14	4	2	-	5				
24674	14	182	4	29	79	160	80	26	13	9	31	56	5	31	34	44	14	4	2	-	5				
24675	34	79	3	29	13	160	80	11	14	9	24	56	5	21	34	310	14	4	2	-	304				
24676	14	312	4	29	62	165	80	11	14	9	302	67	5	21	119	-	14	4	2	-	15				
24677	42	113	4	30	84	192	80	11	13	9	15	56	2	22	18	6	14	4	2	-	15				
24678	14	77	4	29	62	179	121	11	13	9	15	56	5	22	18	6	14	4	2	-	15				
24679	34	166	3	29	62	160	80	26	14	9	67	56	22	22	34	45	14	4	2	-	5				
24680	14	187	4	29	62	160	80	29	13	9	308	70	5	22	18	6	14	4	2	-	15				
24681	14	189	4	29	62	160	80	11	13	9	300	56	5	21	122	46	14	4	2	-	15				
24682	34	190	3	29	13	160	80	11	14	14	24	75	5	21	302	47	14	4	2	-	304				
49500	14	78	4	203	322	413	81	15	13	8	300	56	5	21	107	-	15	4	2	-	15				
49501	14	78	4	203	322	413	81	15	13	8	300	56	5	22	104	7	15	4	2	-	15				
49502	14	78	4	203	323	414	100	15	13	8	300	56	5	23	107	-	15	4	2	-	15				
49503	14	95	4	203	322	413	81	15	13	8	21	56	5	21	107	-	15	4	3	-	15				
49504	14	78	4	203	323	413	81	15	13	8	15	56	5	22	104	7	15	4	2	-	15				
49506	34	80	3	203	325	415	92	15	13	8	301	58	5	21	108	-	15	4	2	-	8				
49507	14	103	4	203	326	166	92	15	14	11	15	56	34	24	46	-	15	4	2	-	15				
49508	300	305	3	26	324	115	93	15	14	8	20	303	5	21	31	-	15	4	8	-	11				
49512	13	101	3	203	327	416	93	15	14	8	8	57	22	26	103	-	15	4	6	-	6				
49514	14	151	4	203	328	171	92	19	13	8	7	58	19	21	109	-	15	4	2	1	8				
49516	13	80	3	26	324	132	110	15	14	8	304	56	10	21	29	-	15	4	2	-	15				
49517	14	400	4	203	323	417	112	15	13	8	16	65	301	21	107	302	15	4	400	-	15				
49519	33	99	3	18	35	120	107	15	13	8	22	58	6	24	33	-	15	4	4	-	8				
49521	14	78	4	203	323	172	112	15	13	8	39	56	5	21	304	302	15	4	2	-	15				
49523	13	111	3	26	324	120	107	15	14	8	304	301	5	21	29	-	15	4	2	-	15				
49525	31	306	4	203	324	418	92	15	13	8	16	65	301	21	107	-	15	4	3	-	15				
49527	42	114	4	18	329	419	81	15	13	8	300	56	2	22	18	-	15	4	2	-	5				
49528	14	78	4	203	322	413	81	15	13	8	24	56	304	22	104	7	15	4	2	-	15				
49529	13	80	3	203	324	171	95	15	14	8	40	63	10	21	107	-	15	4	2	-	15				
49530	42	114	4	203	329	419	81	15	13	8	300	56	2	21	29	-	15	4	2	-	15				
49532	14	78	4	18	324	420	92	15	13	8	15	62	5	21	29	-	15	4	2	-	15				
49533	27	80	3	203	33	163	93	15	13	11	14	60	6	21	100	-	15	4	12	-	15				
49534	305	307	4	203	324	413	81	15	13	8	24	56	5	22	104	308	15	4	2	-	306				
49535	14	78	4	203	324	418	119	15	13	8	302	67	36	21	107	-	15	4	2	-	304				
49537	14	103	4	26	326	119	92	15	14	11	15	56	9	24	46	-	15	4	2	-	5				

Specification Number Index

Group Title & Number	Air Intake	Baffles & Shroud	Breather & Vent	Camshaft & Valves	Carburetor	Crankcase	Crankshaft	Cylinder Head	Dipstick	Electric Start	Exhaust	Flywheel	Fuel Pump	Governor	Ignition	Instrument Panel	Piston & Rod	Oil Pump	Oil Filter	High Temp. Cutout	Oil Pressure Cutout				
	1	2	3	4	5	7	8	9	10	11	12	13	14	17	18	19	22	25	29	31	32				
Page No.	12	14	18	19	20	25	29	31	32	33	35	37	39	41	43	46	49	50	51	54	54				
Grid No.	A11	A14	B4	B5	B6	C2	C7	C9	C10	C11	C13	D1	D3	D5	D7	D10	D13	D14	E1	E7	E7				

Spec. No.	Variation No.																								
49538	300	80	3	18	330	113	81	15	14	8	24	56	5	22	18	15	15	4	2	-	5				
49539	14	78	4	26	330	128	92	15	13	8	39	56	15	21	29	-	15	4	2	-	15				
49540	28	85	3	203	40	115	93	15	14	8	41	304	5	31	49	-	15	4	11	-	11				
49541	14	126	4	18	330	113	81	15	13	8	300	65	5	21	44	-	15	4	2	-	15				
49542	14	78	4	203	330	161	81	15	13	8	42	56	5	22	34	17	15	4	2	-	8				
49543	14	78	4	203	330	168	129	15	13	8	39	300	5	23	104	18	15	4	2	-	5				
49544	34	80	3	203	46	171	92	27	13	8	301	58	5	31	97	-	15	4	2	-	8				
49545	35	80	4	203	333	161	81	15	13	8	34	65	5	31	96	-	15	4	2	-	15				
49546	14	78	4	203	331	172	123	15	13	8	314	63	303	21	107	300	15	4	2	-	26				
49547	302	301	11	204	334	181	124	15	13	8	24	56	2	46	106	-	15	4	2	-	15				
49549	34	80	3	203	33	161	81	20	13	8	27	56	5	21	110	19	15	4	2	1	15				
49550	50	80	10	203	331	172	92	15	13	8	39	56	15	30	107	311	15	4	2	-	15				
49551	42	114	4	204	26	194	125	15	13	8	40	56	2	22	104	20	15	4	2	-	5				
49552	304	302	4	203	76	161	81	15	13	8	57	65	5	24	64	-	15	4	3	-	18				
49553	31	78	4	203	331	161	81	15	20	8	15	58	5	22	18	23	15	4	2	-	15				
49554	13	300	3	203	32	161	81	15	14	8	24	56	5	22	110	22	15	4	2	-	5				
49555	14	78	4	203	331	168	100	15	13	8	300	56	5	23	104	16	15	4	2	-	5				
49556	14	78	4	203	32	161	81	15	13	8	24	56	5	21	107	-	15	4	2	-	15				
49558	31	78	4	203	32	161	137	15	13	8	7	56	5	21	107	-	15	4	2	-	13				
49559	14	78	4	203	32	168	102	15	13	8	302	300	36	22	18	8	15	4	2	-	20				
49560	51	78	4	203	32	161	81	15	13	8	300	56	5	22	104	25	15	4	2	-	15				
49561	52	134	3	203	327	166	92	15	14	11	15	56	34	24	46	-	15	4	2	-	15				
49562	52	134	3	203	327	166	92	15	14	11	15	56	9	24	100	-	15	4	2	-	5				
49563	14	95	4	203	32	161	81	15	13	8	50	56	5	41	67	301	15	4	3	-	6				
49564	303	78	11	205	53	182	125	15	14	8	55	56	16	46	93	-	15	4	2	-	8				
49565	54	142	3	203	81	163	93	15	14	8	41	304	5	31	98	-	15	4	2	-	11				
49566	13	80	3	206	332	421	100	15	14	8	34	56	6	33	108	-	15	4	2	-	15				
49567	305	155	4	203	331	182	125	15	13	8	315	56	25	22	18	308	15	4	2	-	15				
49568	34	134	3	207	331	173	110	15	14	8	304	65	38	21	107	-	15	4	2	-	15				
49569	13	80	3	207	74	182	125	15	14	8	302	56	5	38	106	3	15	4	2	-	5				
49570	35	150	4	207	52	161	81	15	13	8	34	65	5	31	303	-	15	4	2	-	15				
49572	14	78	4	207	335	172	92	15	13	8	309	56	36	31	82	-	15	4	2	-	15				
49573	13	80	3	207	67	412	92	15	14	8	34	67	49	21	108	42	15	4	2	-	8				
49574	14	78	4	207	67	161	81	15	13	8	39	56	5	22	104	29	15	4	2	-	5				
49575	305	303	4	207	67	161	81	15	13	8	25	56	5	22	104	308	15	4	2	-	15				
49576	14	78	4	207	331	172	119	15	13	8	24	67	5	21	107	-	15	4	2	-	304				
49577	14	78	4	207	67	168	100	15	13	8	40	56	5	23	68	-	15	4	2	-	19				
49578	13	80	3	207	75	188	135	15	14	8	34	56	6	33	91	-	15	4	2	-	15				
49579	13	80	3	207	67	172	92	15	14	8	401	56	5	22	104	29	15	4	2	-	5				
49580	32	80	3	207	67	182	125	15	14	8	305	56	5	22	104	29	15	4	2	-	5				
49581	60	159	4	207	67	161	81	27	20	14	15	68	5	22	104	35	15	4	2	-	15				
49582	60	158	4	207	67	182	125	27	13	14	315	75	25	22	104	36	15	4	2	-	15				
49583	14	151	4	31	67	172	95	15	13	8	31	56	36	21	29	-	15	4	2	-	15				
49584	13	177	3	31	86	169	93	27	14	8	8	57	52	26	124	-	15	4	16	-	6				
49585	14	163	4	31	80	194	124	15	13	14	21	79	2	21	91	-	15	4	3	-	8				

Specification Number Index

Group Title & Number	Air Intake	Baffles & Shroud	Breather & Vent	Camshaft & Valves	Carburetor	Crankcase	Crankshaft	Cylinder Head	Dipstick	Electric Start	Exhaust	Flywheel	Fuel Pump	Governor	Ignition	Instrument Panel	Piston & Rod	Oil Pump	Oil Filter	High Temp. Cutout	Oil Pressure Cutout				
	1	2	3	4	5	7	8	9	10	11	12	13	14	17	18	19	22	25	29	31	32				
Page No.	12	14	18	19	20	25	29	31	32	33	35	37	39	41	43	46	49	50	51	54	54				
Grid No.	A11	A14	B4	B5	B6	C2	C7	C9	C10	C11	C13	D1	D3	D5	D7	D10	D13	D14	E1	E7	E7				

Spec. No.	Variation No.																								
49586	14	159	4	31	67	195	119	15	13	14	24	79	5	21	107	-	15	4	2	-	304				
49587	13	80	3	31	44	182	125	15	14	8	59	56	16	34	106	-	15	4	2	-	303				
49588	14	78	4	31	67	168	100	15	13	8	39	56	5	23	107	303	15	4	2	-	15				
49589	14	78	4	31	336	161	81	15	13	8	300	56	5	21	92	-	15	4	2	-	15				
49590	14	78	4	31	32	197	140	15	13	8	302	300	5	22	104	8	15	4	2	-	20				
49591	305	314	4	31	67	161	81	15	13	8	25	80	301	22	104	40	15	4	2	-	25				
49592	32	167	3	31	67	172	92	15	14	8	29	56	5	22	104	38	15	4	13	-	5				
49593	-	-	12	33	82	198	135	31	25	1	15	81	2	-	83	-	15	4	18	-	13				
49594	14	78	4	31	67	172	95	15	13	8	15	56	5	22	104	7	15	4	2	-	15				
49595	14	78	4	31	46	171	95	15	13	8	313	56	5	31	90	-	15	4	2	-	15				
49597	42	114	4	31	26	199	81	15	13	8	40	56	2	21	107	-	15	4	2	-	15				
49598	34	167	3	31	67	161	81	27	14	8	67	56	22	22	110	22	15	4	2	-	5				
49599	14	172	4	31	46	161	81	27	13	8	25	56	5	31	110	41	15	4	2	-	5				
49600	13	80	3	31	67	171	92	15	14	8	303	56	300	21	100	-	15	4	2	-	15				
49601	14	78	4	31	67	171	142	15	13	8	310	56	5	21	108	-	15	4	2	-	21				
49602	34	80	3	31	67	182	124	15	14	8	300	56	5	21	107	305	15	4	2	-	15				
49603	48	142	3	31	87	200	92	27	13	8	70	69	30	21	95	-	15	4	2	-	6				
49604	32	167	3	31	67	172	92	15	14	8	15	56	5	22	104	38	15	4	13	5	-				
49605	13	80	3	31	68	182	125	15	14	8	59	56	16	34	106	-	15	4	2	-	303				
49606	14	78	4	31	67	172	92	15	13	8	300	56	5	22	104	8	15	4	2	-	20				
49607	14	179	4	31	63	163	144	27	13	14	21	82	53	24	100	-	15	4	2	-	15				
49608	14	172	4	31	46	161	81	27	13	8	31	56	5	31	110	41	15	4	2	-	5				
49611	14	78	4	31	67	172	92	15	13	8	39	56	5	21	106	-	15	4	2	-	15				
49612	42	114	4	32	84	199	81	15	13	8	15	56	2	22	104	7	15	4	2	-	15				
49613	14	78	4	31	67	181	124	15	13	8	15	56	5	22	104	7	15	4	2	-	15				
49614	14	78	4	31	67	161	81	15	13	8	300	56	5	22	104	8	15	4	2	-	20				
49615	14	78	4	31	32	197	140	15	13	8	302	300	5	22	104	38	15	4	13	-	5				
49616	14	188	4	32	67	161	81	15	13	8	59	56	5	22	104	29	15	4	2	-	5				
49620	34	191	3	31	67	161	81	27	14	14	24	75	22	22	110	48	15	4	2	-	5				

M18 & M20

Group 1 Air Intake

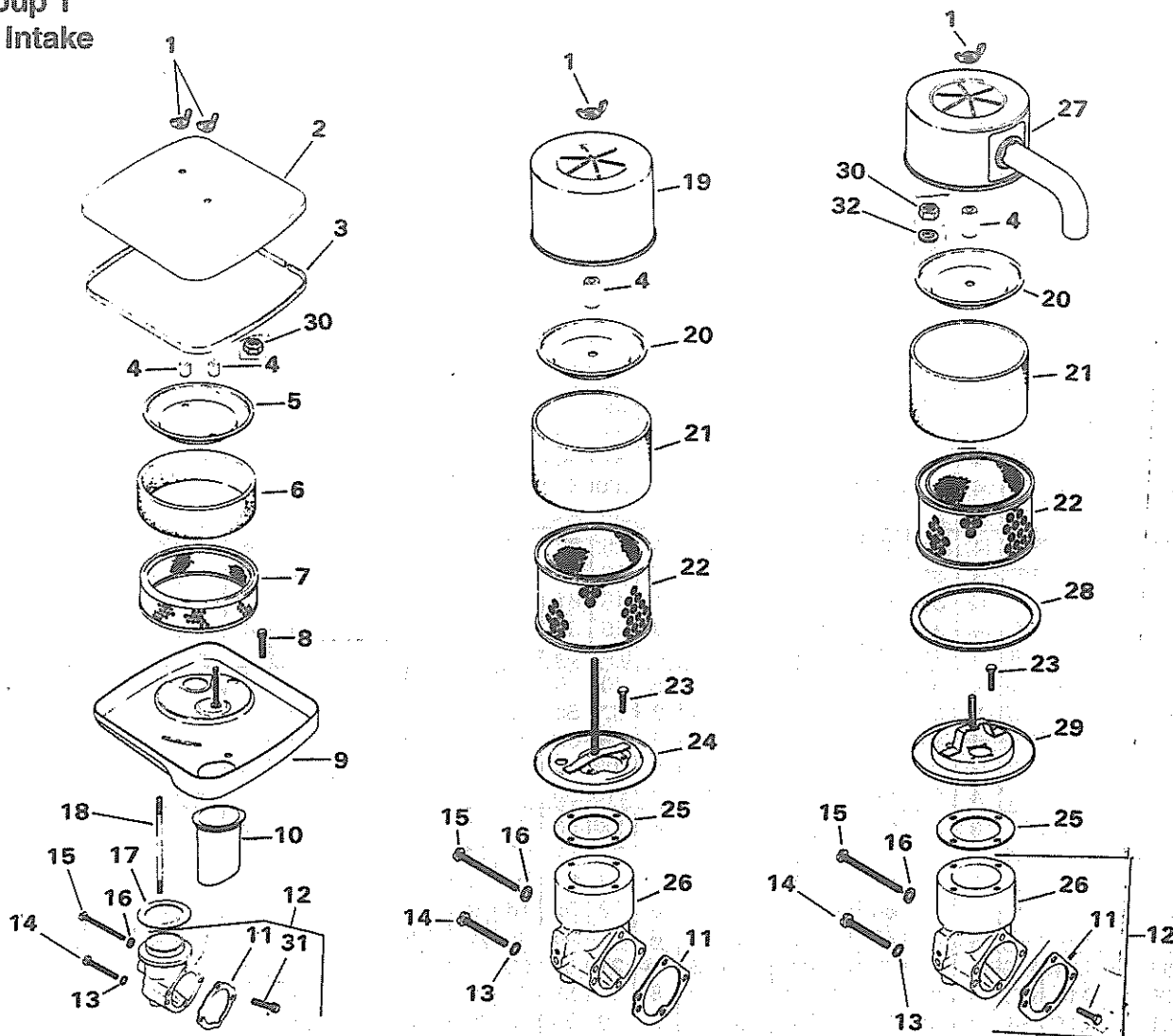

Index Number	Description Variation Number	Part Number	Index Number	Description Variation Number	Part Number
1	Wing nut 1/4-20 13,27,28,29,30,32,33,34,43,48,51, 52,54,58,63,300,301	X-276-7	4	Seal, element cover (2) 60	41 032 02
1	Wing nut 1/4-20 (2) 14,31,35,37,42,60,302,303,304, 305,306	X-276-7	5	Cover, air cleaner element 14,31,35,37,42,51,60,302,303, 304,306	52 082 03
2	Cover, air cleaner – square 14,31,35,37,42,51,60,302,303,304, 305,306	52 082 02	6	Precleaner 14,31,35,37,42,51,60,304,306	52 083 01
3	Seal, air cleaner cover 14,31,35,37,42,51,60,302,303,304, 305,306	52 032 01	7	Element, air cleaner 14,31,35,37,42,51,60,302,303,304, 305,306	47 083 01
4	Seal, element cover 58	52 032 04	8	Screw, hex. wash. hd. 1/4-20x7/16" 14,31,35,37,42,51,60,304,305,306	X-67-83
4	Seal, element cover 13,27,28,29,30,32,33,34,43,48,52, 54,63,300,301,303	231032	9	Base, air cleaner 14,31,35,37,42,51,60,302,303,304, 305,306	52 201 07
4	Seal, element cover (2) 14,31,35,37,42,51,302,304,305,306	231032	10	Tube, air cleaner 14,31,37,42,51,60,304,305	47 134 02
			10	Tube, air cleaner 302,303	52 123 22

Index Number	Description Variation Number	Part Number	Index Number	Description Variation Number	Part Number
11	Gasket, air cleaner elbow 13,14,27,28,29,30,31,32,33,34,35, 37,42,43,48,49,50,51,52,54,58,60, 63,300,301,302,303,304,305,306	25 041 06	26	Elbow, air cleaner (Discontinued not available at Kohler Co.) 37	52 534 04
12	Kit, air intake elbow (Includes 11,31) 13,27,28,29,30,32,33,34,43,48,52, 54,58,63,300,301	52 754 01	26	Elbow, air cleaner 50	52 054 33
12	Kit, air intake elbow (Includes 11,31) 14,31,35,40,42,49,51,60,302,303, 304,305,306	52 754 03	27	Cover, air cleaner 8-5/8" tube 27,54	52 254 11
13	Washer, I.T. #10 (2) 13,14,27,28,29,30,31,32,33,34,35, 37,42,43,48,49,50,51,52,54,58,60, 63,300,301,302,304,305,306	X-22-9	27	Cover, air cleaner without tube 28	52 096 35
14	Screw, sltd. pan hd. 10-32x1-1/2" (2) 13,14,27,28,29,30,31,32,33,34,35, 37,48,49,50,51,52,54,58,60,63,300, 301,302,303,304,305,306	X-50-57	27	Cover, air cleaner 4-7/16" tube 29,32,58	52 254 12
14	Screw, pan hd. mach. 10-32x1-3/4" (2) 42,43	X-50-61	27	Cover, air cleaner 7-5/8" tube 33	52 096 25
15	Screw, sltd. pan hd. 10-32x2-1/4" 13,14,27,28,29,30,31,32,33,34,35, 37,42,43,48,49,50,51,52,54,58,60, 63,300,301,302,303,304,305,306	X-50-37	27	Cover, air cleaner 1-1/2" tube 34,43	52 096 26
16	Washer, plain #10 13,14,27,28,29,30,31,32,33,34,35, 37,42,43,48,49,50,51,52,54,58,60, 63,300,301,302,303,304,305,306	X-25-79	27	Cover, air cleaner 4-1/8" tube 48,63,301	52 096 36
17	Gasket, air cleaner 14,31,35,37,42,51,60,302,303,304, 305,306	52 055 04	28	Seal, air cleaner cover 27,28,29,32,33,34,43,48,52,54,58, 63,301	237423
18	Stud 1/4-20x4-3/4" 14,31,35,37,42,51,60,302,303,304, 305	X-352-38	29	Base, air cleaner 27,28,29,32,33,34,43,48,52,54,58, 63,301	52 201 06
19	Cover, air cleaner - dome 13,30,63	45 082 01	30	Nut, jam 1/4-20 58	41 100 04
20	Cover, air cleaner element 13,27,28,29,30,32,33,34,43,48,52, 54,58,63,300,301	52 082 04	30	Nut, jam 1/4-20 (2) 60	41 100 04
21	Precleaner 13,27,28,29,30,32,33,34,43,48,52, 54,58,63,300,301,302,303,305	45 083 01	31	Screw, hex. wash. hd. 1/4-20x3/4" 14,31,35,40,42,49,51,60,302,303, 304,305,306	X-67-62
22	Element 13,27,28,29,30,32,33,34,43,48,52, 54,58,63,300,301	45 083 02	31	Screw, hex. wash. hd. 1/4-20x5/8" 13,27,28,29,30,32,33,34,43,48,52, 54,58,63,301	52 086 11
23	Screw, hex. wash. hd. 10-32x9/16" (4) 13,27,28,29,30,32,33,34,43,48,52, 54,58,63,300,301	X-67-98	32	Washer, plain 1/4" (2) 60	X-25-12
24	Base, air cleaner 13,30,300	52 094 06	Not Illustrated		
25	Gasket, air cleaner 13,27,28,29,30,32,33,34,43,48,52, 54,58,63,300,301	277093		Decal, air cleaner 63	25 113 15
				Decal, air cleaner 51,304	25 113 08
				Decal, air cleaner 301	25 113 11
				Decal, anti-icing 27,29,32,33,58	52 113 16
				Decal, air cleaner 303	52 113 34
				Decal, air cleaner 13,14,27,29,32,33,34,35,37,42,43, 48,52,54,58,60,300,301,302,303, 305,306	25 113 07

M18 & M20

Group 2 Baffles & Shroud

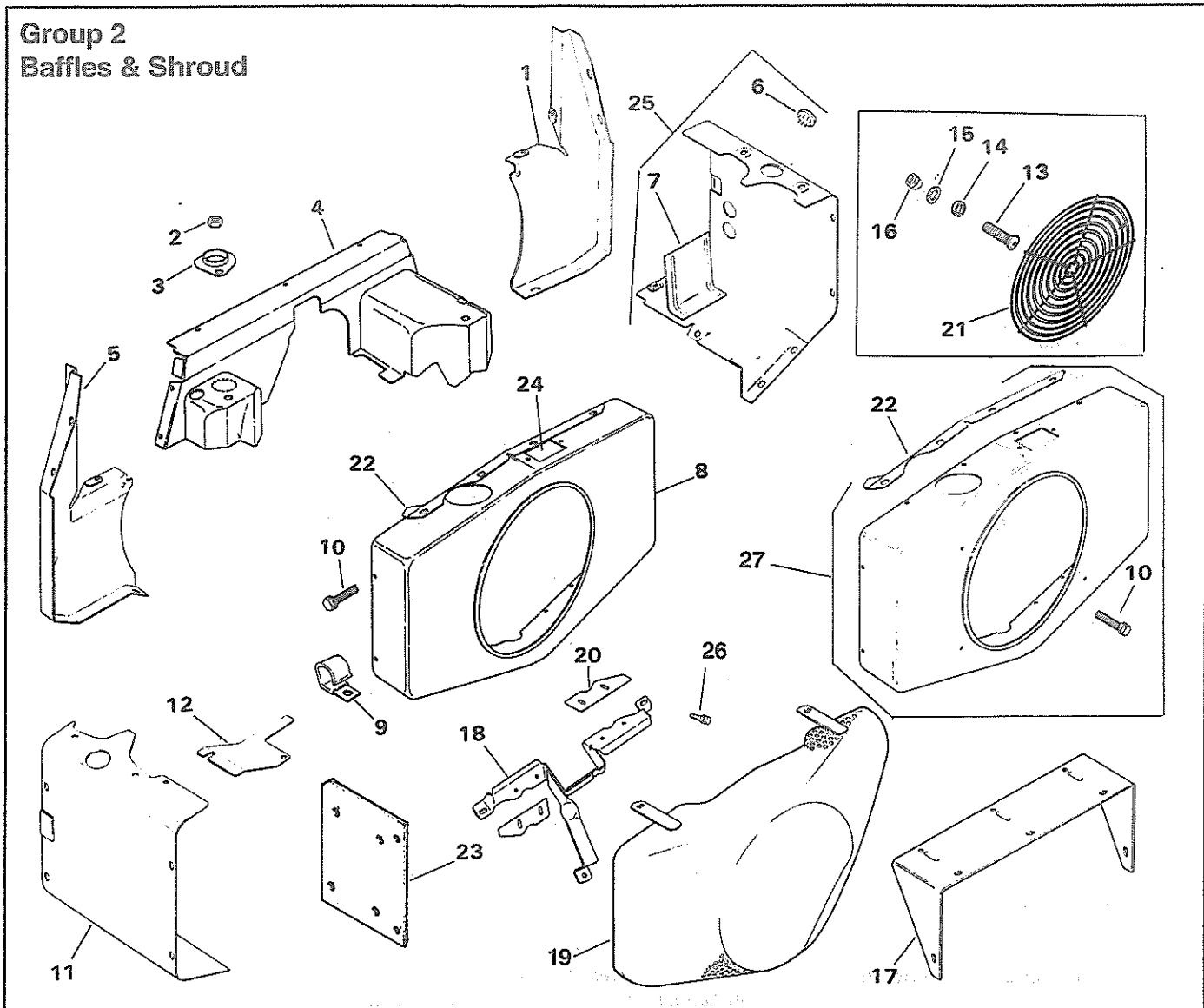

Index Number	Description Variation Number	Part Number	Index Number	Description Variation Number	Part Number
1	Duct, #1 side air 81,82,84,94,98,106,112,131,143, 308,310	52 281 14	2	Nut, hex. 5/16-18 (2) 81,82,84,85,94,95,98,99,106,112,131, 141,142,143,149,151,153,162,163, 172,178,179,182,302,303,305,306, 308,309, 310,314,400,401	X-82-2
1	Duct, #1 side air 401 Before Serial No. 1835500016 use:	52 281 14	2	Nut, hex. 5/16-18 (4) 187	X-82-2
	After Serial No. 1835500006 use:	52 281 21	3	Heater, plate 81,82,99,106,153	52 146 06
1	Duct, #1 side air 85,95,99,163,302,305	52 281 15	4	Cover, air duct 84,85,95,98,112,131,141,142,143, 149,151,162,163,172,178,179,182, 302,303,305,306,308,309,310,312, 314,400,401	52 282 01
1	Duct, #1 side air 400 Before Serial No. 1926500016 use:	52 281 15	4	Cover, air duct - w/heater plate hole 81,82,99,106,153	52 282 03
	After Serial No. 1926500006 use:	52 281 23	5	Duct, #2 side air 81,82,84,94,98,106,112,131,149, 153,178,182,308,310,401	52 281 09
1	Duct, #1 side air 149,153,178,182	52 281 21			
1	Duct, #1 side air 142,151,172,179,303,314	52 281 23			

M18 & M20

Index Number	Description Variation Number	Part Number	Index Number	Description Variation Number	Part Number
5	Duct, #2 side air 85,95,99,142,151,162,163,172,179, 302,303,305,306,314,400	52 281 05	7	Baffle, #1 cylinder head (8-3/4" wide with 5-29/32" rear cylinder baffle) 142,151,172,314,400	52 063 36
6	Plug, button 85,95,101,177,302,305,306	X-301-8	7	Baffle, #1 cylinder head (8-3/4" wide with 5-29/32" rear cylinder head) After Serial No. 1926500006 use: 400	52 063 36
6	Plug, button (2) 81,82,84,98,130,143,308,310	X-301-8	7	Baffle, #1 cylinder head (6-13/64" wide with 2-1/4" rear cylinder baffle) 187	52 063 37
6	Plug, button Before Serial No. 1926500016 use: 400	X-301-8	8	Housing, blower 133,134	52 027 34
7	Baffle, #1 cylinder head (6-1/8" wide with 3" wide rear cylinder baffle) 77,79,94,102,110,113,133,135,152, 156,166,171,189,304,311,312,313	52 124 23	8	Housing, blower 143,156,159,163,178,179,304	52 027 35
7	Baffle, #1 cylinder head (6-1/8" wide with 5-1/8" wide rear cylinder baffle) 78,80,99,103,111,114,126,134,150, 155,158,159,167,188,191,300,301, 307,309	52 124 05	8	Housing, blower 155,158	52 027 32
7	Baffle, #1 cylinder head (8-1/2" wide with 2-1/4" wide rear cylinder baffle and two 7/8" dia. holes) 81,82,84,94,98,106,112,130,131, 143,308,310	52 063 24	8	Housing, blower 171,172,182,187,188	52 027 39
7	Baffle, #1 cylinder head (8-1/2" wide with 2-1/4" wide rear cylinder baffle and two 7/8" dia. holes) Before Serial No. 1835500016 use: 401	52 063 24	8	Housing, blower 190,191	52 027 28
7	Baffle, #1 cylinder head (6-1/8" wide with 5-1/8" wide rear cylinder baffle) 83	52 063 17	9	Clip, fuel line (Replaced by 47 154 01) 82,99,106,110,111	48 154 01
7	Baffle, #1 cylinder head (8-3/4" wide with 5-5/32" wide rear cylinder baffle and three 7/8" dia. holes) (Replaced by 82 755 05) 85,99,101,163,177,302,305,306	52 063 28	10	Screw, hex. wash. hd. 1/4-20x7/16" (14) 130	X-67-83
7	Baffle, #1 cylinder head (8-3/4" wide with 5-5/32" wide rear cylinder baffle and three 7/8" dia. holes) (Replaced by 82 755 05) Before Serial No. 1926500016 use: 400	52 063 28	10	Screw, hex. wash. hd. 1/4-20x7/16" (16) 187	X-67-83
7	Baffle, #1 cylinder head (8-3/4" wide with 3" wide rear cylinder baffle and two 7/8" dia. holes 3-1/8" up) 83,100,176	52 063 18	10	Screw, hex. wash. hd. 1/4-20x7/16" (19) 111	X-67-83
7	Baffle, #1 cylinder head (8-19/32" wide with 5-31/64" rear cylinder baffle) 141,149,153,162,178,182,309	52 063 33	10	Screw, hex. wash. hd. 1/4-20x7/16" (20) 77,78,79,80,83,86,100,101,110,113, 114,155,156,158,159,166,167,171, 176,177,188,190,191,300,301,304, 307,311,312,313	X-67-83
7	Baffle, #1 cylinder head (8-19/32" wide with 5-31/64" rear cylinder baffle) After Serial No. 1835500006 use: 401	52 063 33	10	Screw, hex. wash. hd. 1/4-20x7/16" (21) 94,126,152,162	X-67-83
			10	Screw, hex. wash. hd. 1/4-20x7/16" (22) 135,150,189	X-67-83
			10	Screw, hex. wash. hd. 1/4-20x7/16" (23) 133,134,149,309,314,401	X-67-83
			10	Screw, hex. wash. hd. 1/4-20x7/16" (24) 102,103	X-67-83
			10	Screw, hex. wash. hd. 1/4-20x7/16" (26) 81	X-67-83
			10	Screw, hex. wash. hd. 1/4-20x7/16" (27) 82,84,85,95,98,112,131,143,163, 302,305,306,308,310	X-67-83
			10	Screw, hex. wash. hd. 1/4-20x7/16" (29) 141,142,151,178,179,182,303,400	X-67-83
			10	Screw, hex. wash. hd. 1/4-20x7/16" (31) 99,106	X-67-83
			10	Screw, hex. wash. hd. 1/4-20x7/16" (32) 153	X-67-83
			10	Screw, hex. wash. hd. 1/4-20x7/16" (34) 172	X-67-83

Baffles & Shroud
(Cont.)

M18 & M20

Index Number	Description Variation Number	Part Number	Index Number	Description Variation Number	Part Number
11	Baffle, #2 cylinder head (8-3/4" wide with 5-7/32" wide rear cylinder baffle) 78,80,85,95,101,103,111,114,126,134,142,150,151,155,158,159,163,167,172,177,179,188,191,300,301,302,303,305,306,307,314,400	52 063 30	15	Spacer (5) 155,158,166,167,171,172,182,188	52 112 12
11	Baffle, #2 cylinder head (8-3/4" wide with 2-59/64" wide rear cylinder baffle) 77,79,81,82,84,94,98,100,102,106,110,112,113,130,131,133,135,141,143,149,152,153,156,162,166,171,176,178,182,304,308,309,310,311,312,313,401	52 063 21	15	Spacer (5) (Use after Serial No. 2007480006, but before Serial No. 2010200016) 307	52 112 12
11	Baffle, #2 cylinder head (8-3/4" wide with 2-59/64" wide rear cylinder baffle and two 3/8" dia. holes) 187	52 063 38	15	Spacer (4) 187	X-400-89
12	Baffle, fuel pump 77,78,79,80,81,82,83,84,85,94,95,98,99,100,101,102,103,106,110,111,126,130,131,133,134,135,141,143,149,150,151,152,153,155,156,158,159,166,167,171,172,182,187,188,189,190,191,300,302,303,304,305,306,307,308,310,311,312,314,400,401	52 063 01	16	Nut, elastic 10-32 (5) (Use after Serial No. 2007400006, but before Serial No. 2010200016) 307	X-101-12
12	Baffle, fuel pump 86,112,113,114,163	52 063 02	16	Nut, elastic 10-32 (5) 155,166,167,171,172,182,188	X-101-12
12	Baffle, fuel pump 176,177,178,179	52 063 39	17	Guard, muffler 82,106,172,182	52 314 04
13	Screw, hex. wash. hd. 1/4-20x5/8" (2) 77,78,79,80,81,82,83,84,85,94,95,98,99,100,101,102,103,110,111,112,113,114,126,130,131,135,141,142,150,151,152,153,162,166,167,176,177,189,300,301,302,303,305,306,308,309,310,311,312,313,314,400	52 086 11	17	Guard, muffler - chrome 99	52 314 05
13	Screw, hex. wash. hd. 1/4-20x5/8" (6) 149,307,401	52 086 11	18	Deflector, grass 102,103,133,134	52 265 04
13	Screw, hex. wash. hd. 1/4-20x5/8" (4) 187	52 086 11	19	Screen, grass 99	52 162 26
14	Washer, flat (5) (Use after Serial No. 2007400006, but before Serial No. 2010200016) 307	25 468 03	19	Screen, grass 82,106	52 162 24
14	Washer, flat 3/16" I.D. x 5/8" O.D. x 1/16" (5) 155,158,166,167,171,172,182,188	25 468 03	20	Plate (2) 102,103,133,134	52 146 05
14	Washer, lock 5/16" (4) 187	X-21-1	21	Guard, grass screen 155,158,166,167,171,172,182,188	47 314 01
14	Washer, E.T. #10 (4) 102,103,133,134	X-22-22	21	Guard, grass screen (Use after Serial No. 2007400006, but before Serial No. 2010200016) 307	47 314 01
14	Washer, flat (2) 77,78,79,80,81,82,83,84,85,94,98,99,100,101,102,103,106,110,111,112,113,114,126,130,131,135,140,141,142,149,150,151,152,153,162,166,167,176,177,189,300,301,303,305,306,307,308,310,311,312,313,314,400,401	52 468 16	22	Bracket, upper housing 77,78,79,80,81,82,83,84,85,86,94,95,98,99,100,101,102,103,106,110,111,112,113,114,126,130,131,133,134,135,141,142,143,149,150,151,152,153,155,156,158,159,162,163,166,167,171,172,176,177,178,179,182,187,188,189,190,191,300,301,302,303,304,305,306,307,308,309,310,311,312,313,314,400,401	52 217 01
			23	Bracket, blower housing (2) 187	52 126 17
			24	Cover, knockout 126,135,150,152,189	41 096 23
			25	Kit, baffle (Includes 6) 85,95,99,101,163,177,302,305,306	82 755 05
			25	Kit, baffle (Includes 6) After Serial No. 1926500006 use: 400	82 755 05
			26	Screw, hex. wash. hd. 10-32x7/16" (4) 102,103,133,134	X-67-64
			27	Housing, blower (Includes 10 [qty. 3], 13 [qty. 2], 14 [qty. 2], 22) 79,80,81,82,83,84,85,99,100,101,106,110,111,131,135,141,142,150,153,162,176,177,300,305,308	52 755 71

M18 & M20

Index Number	Description Variation Number	Part Number	Index Number	Description Variation Number	Part Number
27	Housing, blower (Includes 10 [qty. 3], 13 [qty. 2], 14 [qty. 2], 22) 166, 167	82 755 01			
27	Kit, blower housing (Includes 10 [qty. 3], 13 [qty. 2], 14 [qty. 2], 22) 102, 103	52 755 72			
27	Kit, blower housing (Includes 10 [qty. 3], 13 [qty. 2], 14 [qty. 2], 22) 77, 78, 94, 95, 98, 112, 113, 114, 126, 130, 149, 151, 152, 189, 301, 302, 303, 306, 309, 310, 311, 312, 313, 314, 400, 401	52 755 70			
27	Kit, blower housing 307 Before Serial No. 2007400016 use: After Serial No. 2007400006, but before Serial No. 2010200016 use: After Serial No. 2010200006 use:	52 755 70 82 755 01 52 027 33			
				Not Illustrated	
				Decal, grass deflector 102, 103, 133, 134	52 113 11
				Decal, 20 HP, white 155, 158, 300, 301, 303, 305, 306, 307, 314	52 113 34
				Decal, 20 HP, black 302, 306	52 113 35
				Decal, 18 HP, black (Discontinued not available at Kohler Co.) 304, 310, 313	52 113 33
				Decal, 18 HP, white 106, 308, 309, 311	52 113 32

M18 & M20

Group 3 Breather & Vent

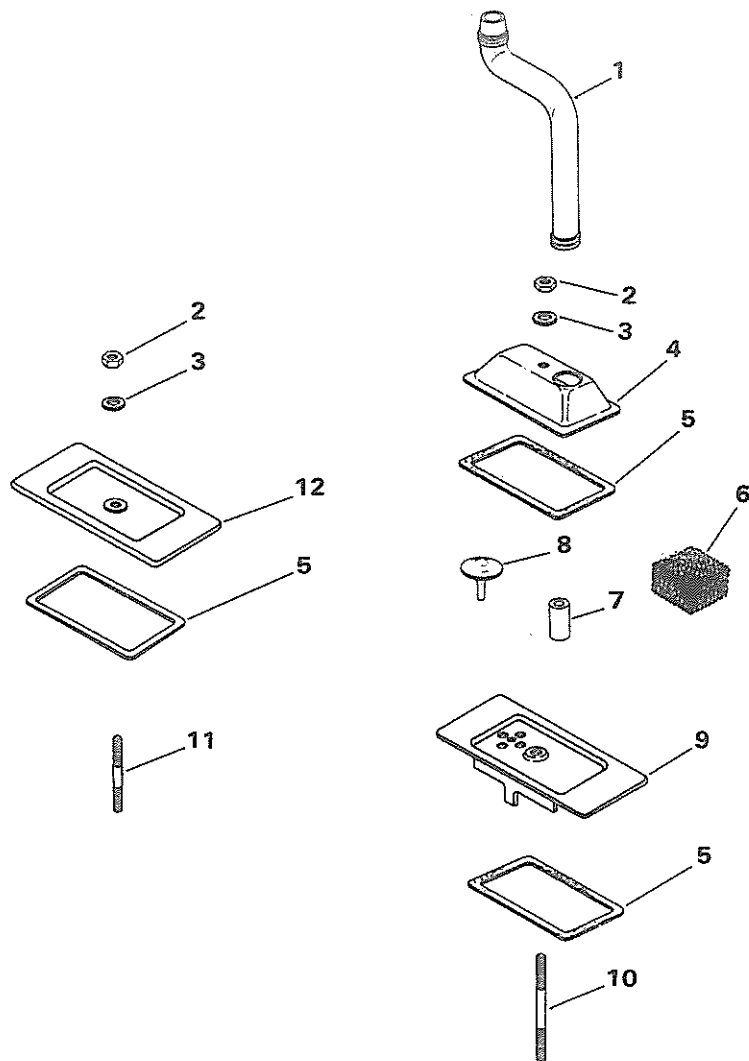

Index Number	Description Variation Number	Part Number	Index Number	Description Variation Number	Part Number
1	Hose, breather 4-3/8" 3	52 326 05	8	Valve, umbrella 3,4,10,11,12	52 462 01
1	Hose, breather 3-5/8" 4	52 326 06	9	Cover, #1 lower cylinder valve 3,4,10,11	52 096 22
1	Hose, breather 10	52 326 03	9	Cover, #1 lower cylinder valve 12	52 096 41
1	Hose, breather 11	52 326 13	10	Stud, #1 cylinder valve cover – 1/4-20x3-1/4" 3,4,10,11,12	275220
2	Nut, hex. 1/4-20 (2) 3,4,10,11,12	X-81-1	11	Stud, #2 cylinder valve cover – 1/4-20x2-1/4" 3,4,10,11,12	X-352-39
3	Washer, plain 1/4" (2) 3,4,10,11,12	X-25-12	12	Cover, #2 cylinder valve 3,4,10,11	52 096 18
4	Cover, #1 upper cylinder valve 3,4,10,11	52 096 08	12	Cover, #2 cylinder valve 12	52 096 40
4	Cover, #1 upper cylinder valve 12	52 096 43			
5	Gasket, valve cover (3) 3,4,10,11,12	52 055 01			
6	Filter, breather 3,4,10,11,12	231419			
7	Seal, breather 3,4,10,11,12	52 032 04			
				Not Illustrated	
				Plug, breather (Discontinued not available at Kohler Co.) 12	X-519-5

M18 & M20

Group 4 Camshaft & Valves

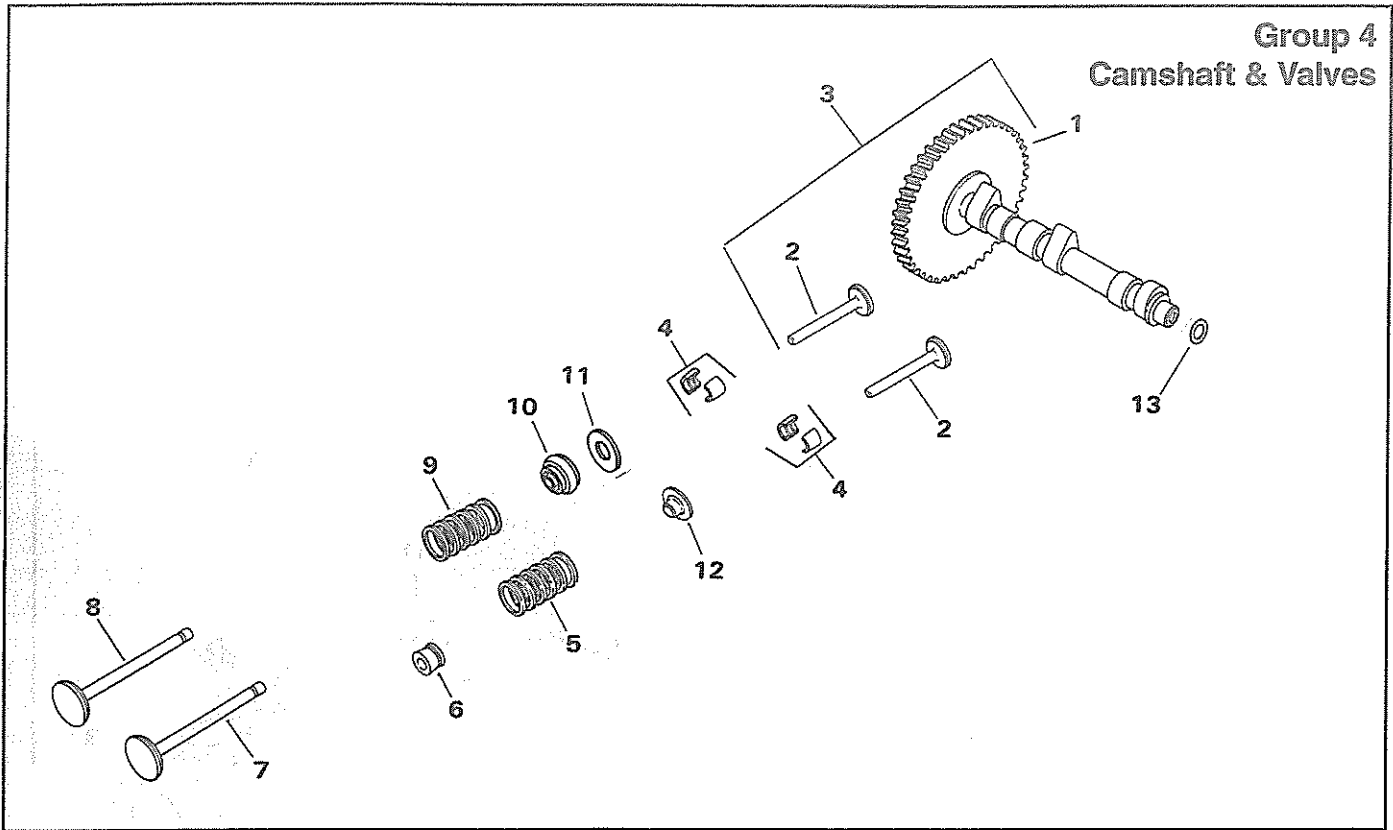

Index Number	Description Variation Number	Part Number	Index Number	Description Variation Number	Part Number
1	Camshaft 33,34	52 010 04	8	Kit, exhaust valve (2) (Includes 52 031 01 valve seat insert) 17,28,200,201,202	82 755 11
1	Camshaft 29,30,31,32	52 012 09	8	Kit, exhaust valve (2) (Includes 52 031 01 valve seat insert) 18,26,203,204,205,206,207	82 755 12
2	Tappet (4) 29,30,31,32,33,34	52 019 03	8	Valve, exhaust (2) 29,30,34	52 016 05
3	Kit, camshaft (Includes 1, 52 019 03 [qty. 4]) 17,18,26,28,200,201,202,203,204, 205,206,207	82 755 13	8	Valve, exhaust (2) 31,32,33	52 016 06
4	Kit, retainer (4) 17,18,26,28,29,30,31,32,33,34,200, 201,202,203,204,205,206,207	41 755 10	9	Spring, exhaust valve (2) 17,18,26,28,29,30,31,32,33,34,200, 201,202,203,204,205,206,207	25 089 01
5	Spring, intake valve (2) 17,18,26,28,29,30,31,32,33,34,200, 201,202,203,204,205,206,207	25 089 01	10	Rotator, .03" exhaust valve (2) 17,18,26,28,29,31,33,34,200,201, 203,206,207	52 413 01
6	Seal, intake valve stem (2) 17,18,26,28,29,30,31,32,33,34,200, 201,202,203,204,205,206,207	52 032 13	11	Spacer, .03" exhaust (2) 30,32,202,204,205	52 112 10
7	Valve, intake (2) 17,28,29,30,34,200,201,202	52 017 08	12	Retainer, intake valve spring (2) 17,18,26,28,29,31,33,34,200,201, 203,206,207	230011
7	Valve, intake (2) 18,26,31,32,33,203,204,205,206, 207	52 017 07	12	Retainer, intake valve spring (4) 30,32,202,204,205	230011
			13	Spacer, camshaft .005 (A.R.) 33,34	52 422 03

M18 & M20

Group 5 Carburetor

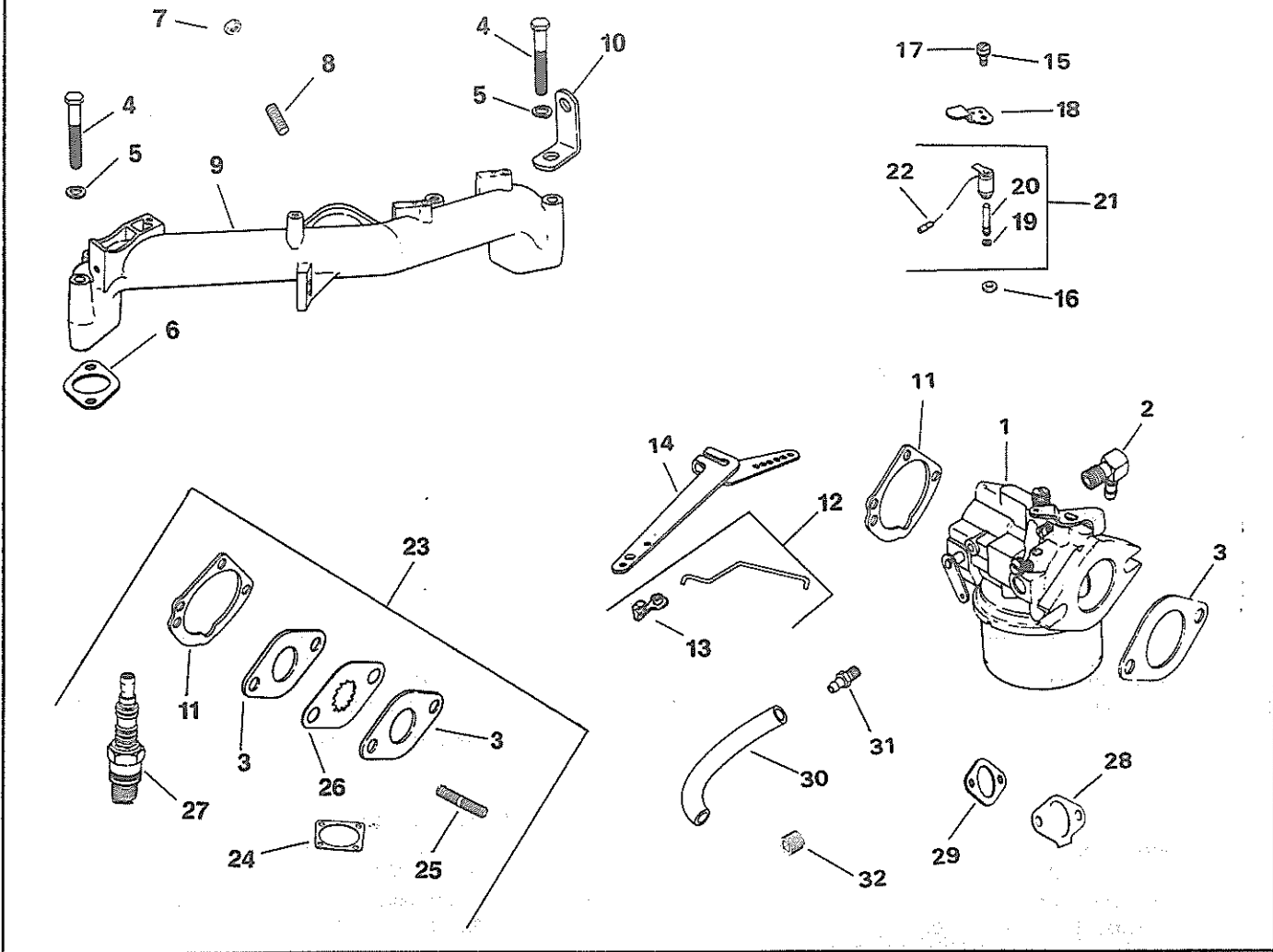

Index Number	Description Variation Number	Part Number	Index Number	Description Variation Number	Part Number
<p>Refer to Section 3 of Carburetor Reference Manual TP-2377-D, located in Miscellaneous Special Service Parts Information section of your Master Manual, for breakdown of the following carburetor assemblies:</p>			1	<p>Carburetor assembly 30,302 Before Serial No. 1629500996 use: Adjustable jet assembly After Serial No. 1629500986 use: Kit, fixed carburetor (Includes 3,11-14, Carburetor assembly 52 053 27*, 52 053 32*, 52 053 35*) - or use - Kit, fixed jet carburetor (Includes 3,11-14, Carburetor assembly 52 053 51*)</p>	52 053 18 52 853 04 52 853 30
1	<p>Kit, adjustable jet carburetor (Includes 3,11-14, Carburetor assembly 52 053 31*, 52 053 50*, 53 053 66*) 13,312</p>	52 853 23	1	<p>Kit, adjustable jet carburetor (Includes 3,11-14, Carburetor assembly 52 053 58* or 52 053 63*) 32,67,75,87</p>	52 853 27
1	<p>Kit, fixed jet carburetor (Includes 3,11-14, Carburetor assembly 52 053 26*, 52 053 31*, 52 053 36*) 29,304,308,309,310 - or use - Kit, adjustable jet carburetor (Includes 3,11-14, Carburetor assembly 52 053 50* or 52 053 66*)</p>	52 853 07 52 853 23	<p>*NOTE: Marked Carburetors are for information only, not available separately.</p>		

M18 & M20

Carburetor
(Cont.)

Index Number	Description Variation Number	Part Number	Index Number	Description Variation Number	Part Number
1	Kit, fixed jet carburetor (Includes 3,11-14, Carburetor assembly 52 053 20* or 52 053 46*) 33,323,330,331,332 - or use -	52 853 01	1	Carburetor assembly 300,303,306 Before Serial No. 1630206306 use: Adjustable jet assembly After Serial No. 1630206316 use: Kit, fixed jet carburetor (Includes 3,11-14, Carburetor assembly 52 053 26*, 52 053 31*, 52 053 36*) - or use -	52 053 09
	Kit, adjustable jet carburetor (Includes 3,11-14, Carburetor assembly 52 053 58* or 52 053 63*)	52 853 27		Kit, adjustable jet carburetor (Includes 3,11-14, Carburetor assembly 52 053 50* or 52 053 66*)	52 853 07
1	Kit, fixed jet carburetor (Includes 3,11-14, solenoid, Carburetor assembly 52 053 37*) 41,45,51,316 - or use -	52 853 21	1	Carburetor assembly 301 Before Serial No. 1629500996 use: Adjustable jet assembly After Serial No. 1629500986 built with: Kit, fixed jet carburetor (Includes 3,11-14, Carburetor assembly 52 053 27*, 52 053 32*, 52 053 34) - or built with -	52 053 18
	Kit, adjustable jet carburetor (Includes 3,11-14,16-20, solenoid, Carburetor assembly 52 053 52*)	52 853 24		Kit, fixed jet carburetor (Includes 3,11, Carburetor assembly 52 053 34*) - or built with -	52 853 04
1	Kit, adjustable jet carburetor (Includes 3,11-14, Carburetor assembly 52 053 50* or 52 053 66*) 43,62,71,78,88	52 853 23		Kit, adjustable jet carburetor (Includes 3,11, Carburetor assembly 52 053 54*) - or built with -	52 853 09
1	Kit, fixed jet carburetor (Includes 3,11-13,16-20, solenoid, Carburetor assembly 52 053 38*) 46,52,74,81 - or use -	52 853 22		Kit, adjustable jet carburetor (Includes 3,11-14, Carburetor assembly 52 053 51*)	52 853 25
	Kit, adjustable jet carburetor (Includes 3,11-14,16-20, solenoid, Carburetor assembly 52 053 56*)	52 853 26	1	Carburetor assembly 305 Before Serial No. 1630206306 use: Adjustable jet assembly After Serial No. 1630206316 thru 1822800016 use: Kit, fixed jet carburetor (Includes 3,11-14, Carburetor assembly 52 053 26*, 52 053 31*, 52 053 36*) - or use -	52 853 30
1	Kit, adjustable jet carburetor (Includes 3,11-14, Carburetor assembly 52 053 59*) 63	52 853 28		Kit, adjustable jet carburetor (Includes 3,11-14, Carburetor assembly 52 053 50* or 52 053 66*) After Serial No. 1822800006 use: Carburetor assembly (Includes 35-49, Carburetor repair kit 25 757 02, T & C shaft repair kit 25 757 05)	52 853 07
1	Kit, fixed jet carburetor (Includes 3,11-14, Carburetor assembly 52 053 21* or 52 053 47*) 76,327 - or use -	52 853 02		Kit, adjustable jet carburetor (Includes 3,11-14, Carburetor assembly 52 053 27*, 52 053 32*, 52 053 34*) 311 - or use -	52 853 23
	Kit, adjustable jet carburetor (Includes 3,11-14, Carburetor assembly 52 053 59*)	52 853 28		Kit, adjustable jet carburetor (Includes 3,11-14, Carburetor assembly 52 053 51*)	52 853 30
1	Kit, adjustable jet carburetor (Includes 11-14,16-20, solenoid, Carburetor assembly 52 053.52) 79	52 853 24	1	Kit, fixed jet carburetor (Includes 3,11-14, Carburetor assembly 52 053 27*, 52 053 32*, 52 053 34*) 311 - or use -	52 053 09
1	Kit, adjustable jet carburetor (Includes 3,11,31, Carburetor assembly 52 053 69*) 82	52 853 32		Kit, adjustable jet carburetor (Includes 3,11-14, Carburetor assembly 52 053 51*)	52 053 09
1	Kit, adjustable jet carburetor (Includes 3,11-14, Carburetor assembly 52 053 58* or 52 053 63*) (Use before Serial No. 2121800016) 86 After Serial No. 2121800006 use: Kit, adjustable jet carburetor (Includes 3,11-13,16-20, solenoid, Carburetor assembly 52 053 56*)	52 853 27			52 053 64
	Kit, adjustable jet carburetor (Includes 3,11-14, Carburetor assembly 52 053 59*)	52 853 28			52 053 04
	Kit, adjustable jet carburetor (Includes 3,11-13,16-20, solenoid, Carburetor assembly 52 053 56*)	52 853 26			52 853 04

*NOTE: Marked Carburetors are for information only, not available separately.

**Carburetor
(Cont.)**

M18 & M20

Index Number	Description Variation Number	Part Number	Index Number	Description Variation Number	Part Number
1	Kit, fixed jet carburetor (Includes 3,11-14, Carburetor assembly 52 053 26*, 52 053 31*, 52 053 36*) (Use before Serial No. 2129800016) 313	52 853 07	1	Kit, adjustable jet carburetor (Includes 3,11-14, Carburetor assembly 52 053 50* or 52 053 66*) (Use before Serial No. 2014500016) 319	52 853 23
	- or use -			After Serial No. 2014500006 use:	
	Kit, adjustable jet carburetor (Includes 3,11-14, Carburetor assembly 52 053 50* or 52 053 66*)	52 853 23		Kit, adjustable jet carburetor (Includes 3,11-14,16-20, solenoid, Carburetor assembly 52 053 52*)	52 853 24
	After Serial No. 2129800006 use:		1	Kit, adjustable jet carburetor (Includes 3,11-14, Carburetor assembly 52 053 50* or 52 053 66*) (Use before Serial No. 1924900016) 320	52 853 23
1	Kit, fixed jet carburetor (Includes 3,11-14, Carburetor assembly 52 053 26*, 52 053 31*, 52 053 36*) (Use before Serial No. 1735100016) 314	52 853 07		After Serial No. 1924900006 use:	
	- or use -			Kit, adjustable jet carburetor (Includes 11-14,16-20, solenoid, Carburetor assembly 52 053 52*)	52 853 24
	Kit, adjustable jet carburetor (Includes 3,11-14, Carburetor assembly 52 053 50* or 52 053 66*)	52 853 23	1	Kit, adjustable jet carburetor (Includes 3,11-14, Carburetor assembly 52 053 50* or 52 053 66*) (Use before Serial No. 2207700016) 321	52 853 23
	After Serial No. 1735100006 use:			After Serial No. 2207700006 use:	
	Kit, fixed jet carburetor (Includes 3,11-14,16-20, solenoid, Carburetor assembly 52 053 37*)	52 853 21		Kit, adjustable jet carburetor (Includes 3,11-14, Carburetor assembly 52 053 51*)	52 853 30
	- or use -		1	Carburetor assembly 322,324,325	
	Kit, adjustable jet carburetor (Includes 3,11-14,16-20, solenoid, Carburetor assembly 52 053 52*)	52 853 24		Before Serial No. 1619504216 use:	
1	Kit, fixed jet carburetor (Includes 3,11-14, Carburetor assembly 52 053 26*, 52 053 31*, 52 053 36*) (Use before Serial No. 2002500016) 315	52 853 07		Adjustable jet assembly	52 053 09
	- or use -			After Serial No. 1619504206 use:	
	Kit, adjustable jet carburetor (Includes 3,11-14, Carburetor 52 053 50* or 52 053 66*)	52 853 23		Kit, fixed jet carburetor (Includes 3,11-14, Carburetor assembly 52 053 20* or 52 053 46*)	52 853 01
	After Serial No. 2002500006 use:			- or use -	
	Kit, adjustable jet carburetor (Includes 3,11-14,16-20, solenoid, Carburetor assembly 52 053 52*)	52 853 24		Kit, adjustable jet carburetor (Includes 3,11-14, Carburetor assembly 52 053 58* or 52 053 63*)	52 853 27
1	Kit, adjustable jet carburetor (Includes 3,11-14, Carburetor assembly 52 053 50* or 52 053 66*) (Use before Serial No. 2008100016) 318	52 853 23	1	Carburetor assembly 326	
	After Serial No. 2008100006 use:			Before Serial No. 1619504216 use:	
	Carburetor assembly (Includes 34-49, (Carburetor repair kit 25 757 02, T & C kit shaft repair 25 757 05)	52 053 64		Adjustable jet assembly	52 053 18
				After Serial No. 1619504206 use:	
				Kit, fixed jet carburetor (Includes 3,11-14, Carburetor assembly 52 053 21* or 52 053 47*)	52 853 02
				- or use -	
				Kit, adjustable jet carburetor (Includes 3,11-14, Carburetor assembly 52 053 59*)	52 853 28

*NOTE: Marked Carburetors are for information only, not available separately.

M18 & M20

Carburetor
(Cont.)

Index Number	Description Variation Number	Part Number	Index Number	Description Variation Number	Part Number
1	Kit, fixed jet carburetor (Includes 3,11-14, Carburetor assembly 52 053 20* or 52 053 46*) (Use before Serial No. 2130400016) 328	52 853 01	2	Connector, 90° hose (For 1/4" I.D. rubber hose) 13,27,29,30,32,33,41,43,44,45,46, 51,52,53,61,62,63,67,68,71,74,75, 76,78,79,80,81,86,87,88,300,301, 302,303,304,305,306,308,309,310, 311,312,313,314,315,316,317,318, 319,320,321,322,323,324,325,326, 327,328,329,330,331,332,333,334, 335,336,337	25 155 02
	- or use -		3	Gasket, carburetor 13,26,27,29,30,31,32,33,41,43,44, 45,46,51,52,53,61,62,63,67,68,71, 74,75,76,78,79,80,81,84,86,87,88, 300,301,302,303,304,305,306,307, 308,309,310,311,312,313,314,315, 316,317,318,319,320,321,322,323, 324,325,326,327,328,329,330,331, 332,333,334,335,336	271030
1	Kit, adjustable jet carburetor (Includes 3,11-14, Carburetor assembly 52 053 58* or 52 053 63*) After Serial No. 2130400006 use:	52 853 27	3	Gasket, carburetor 82,337	210223
	Kit, adjustable jet carburetor (Includes 3,11-14,16-20, solenoid, Carburetor assembly 52 053 56*)	52 853 26	4	Screw, H.C. 5/16-18x2-3/4" (4) 13,26,27,29,30,31,32,33,41,43,44, 45,46,51,52,53,61,62,63,67,68,71, 74,75,76,78,79,80,81,84,86,87,88, 300,301,302,303,304,305,306,307, 308,309,310,311,312,313,314,315, 316,317,318,319,320,321,322,323, 324,325,326,327,328,329,330,331, 332,333,334,335,336,337	X-6-8
1	Kit, fixed jet carburetor (Includes 3,11-14, Carburetor assembly 52 053 20* or 52 053 46*) (Use before Serial No. 1735100016) 333	52 853 01	4	Screw, H.C. 5/16-18x2" (2) 82	X-6-29
	- or use -		5	Washer, lock 5/16" (4) 13,26,27,29,30,31,32,33,41,43,44, 45,46,51,52,53,61,62,63,67,68,71, 74,75,76,78,79,80,81,82,84,86,87, 88,300,301,302,303,304,305,306, 307,308,309,310,311,312,313,314, 315,316,317,318,319,320,321,322, 323,324,325,326,327,328,329,330, 331,332,333,334,335,336,337	X-21-1
	Kit, adjustable jet carburetor (Includes 3,11-14, Carburetor assembly 52 053 58* or 52 053 63*) After Serial No. 2003300016) 335	52 853 27	6	Gasket, intake manifold (2) 13,26,27,29,30,31,32,33,41,43,44, 45,46,51,52,53,61,62,63,67,68,71, 74,75,76,78,79,80,81,82,84,86,87, 88,300,301,302,303,304,305,306, 307,308,309,310,311,312,313,314, 315,316,317,318,319,320,321,322, 323,324,325,326,327,328,329,330, 331,332,333,334,335,336,337	52 041 09
	After Serial No. 2003300006 use:		7	Nut, hex. jam 5/16-18 (2) 13,26,27,29,30,31,32,33,41,43,44, 45,46,51,52,53,61,62,63,67,68,71, 74,75,76,78,79,80,81,84,86,87,88, 300,301,302,303,304,305,306,307, 308,309,310,311,312,313,314,315, 316,317,318,319,320,321,322,323, 324,325,326,327,328,329,330,331, 332,333,334,335,336,337	X-77-2
	Kit, adjustable jet carburetor (Includes 3,11-13,16-20, solenoid, Carburetor assembly 52 053 56*)	52 853 26	7	Nut, hex. 1/4-20 (2) 82	X-76-2
1	Kit, adjustable jet carburetor (Includes 3,11-14, Carburetor assembly 52 053 58* or 52 053 63*) (Use before Serial No. 2008000016) 336	52 853 27			
	After Serial No. 2008000006 use:				
	Carburetor assembly (Includes 39-49, Carburetor repair kit 25 757 02, T & C shaft repair kit 25 757 05)	52 053 64			
1	Kit, adjustable jet carburetor (Includes 3,11-14, Carburetor assembly 52 053 50* or 52 053 66*) (Use before Serial No. 2121800016) 337	52 853 23			
	After Serial No. 2121800006 use:				
	Kit, adjustable jet carburetor (Includes 11-14,16-20, solenoid, Carburetor assembly 52 053 52*)	52 853 24			

*NOTE: Marked Carburetors are for information only, not available separately.

Carburetor
(Cont.)

M18 & M20

Index Number	Description Variation Number	Part Number	Index Number	Description Variation Number	Part Number
8	Stud 5/16-18x1" (2) 13,26,27,29,30,31,32,33,41,43,44, 45,46,51,52,53,61,62,63,67,68,71, 74,75,76,78,79,80,81,84,86,87,88, 300,301,302,303,304,305,306,307, 308,309,310,311,312,313,314,315, 316,317,318,319,320,321,322,323, 324,325,326,327,328,329,330,331, 332,333,334,335,336,337	X-352-37	12	Kit, governor linkage (Use before Serial No. 2008100016) 318	82 755 07
9	Manifold, intake (Discontinued not available at Kohler Co.) 27	52 164 09	12	Kit, governor linkage 313 Before Serial No. 2129800016 use: After Serial No. 2129800006 use:	82 755 07 82 755 06
9	Manifold, intake 13,26,29,30,31,32,33,41,43,45,46, 61,62,63,67,71,75,76,78,79,80,81, 86,87,88,300,301,302,303,304,305, 306,307,308,309,310,311,312,313, 315,316,318,319,320,321,322,323, 324,325,326,327,328,329,330,331, 332,335,336,337	52 164 10	12	Kit, governor linkage 315 Before Serial No. 2002500016 use: After Serial No. 2002500006 use:	82 755 07 82 755 06
9	Manifold, intake 44,51,52,53,68,313,317,333,334	52 164 16	12	Kit, governor linkage 319 Before Serial No. 2014500016 use: After Serial No. 2014500006 use:	82 755 07 82 755 06
9	Manifold, intake 74,84	52 164 19	12	Kit, governor linkage 320 Before Serial No. 1924900016 use: After Serial No. 1924900006 use:	82 755 07 82 755 06
9	Manifold, intake 82	52 164 20	12	Kit, governor linkage 328 Before Serial No. 2130400016 use: After Serial No. 2130400006 use:	82 755 07 82 755 06
10	Strap, lifting (2) 13,26,27,29,30,31,32,33,41,43,44, 45,46,51,52,53,61,62,63,67,68,71, 74,75,76,78,79,80,81,84,86,87,88, 300,301,302,303,304,305,306,307, 308,309,310,311,312,313,314,315, 316,317,318,319,320,321,322,323, 324,325,326,327,328,329,330,331, 332,333,334,335,336,337	52 445 02	12	Kit, governor linkage 333 Before Serial No. 1735100016 use: After Serial No. 1735100006 use:	82 755 07 82 755 06
11	Gasket, air cleaner 13,26,29,30,31,32,33,41,43,45,46, 51,52,53,62,63,67,68,71,74,75,76, 78,79,81,84,86,87,88,300,301,302, 303,304,305,306,307,308,309,310, 311,312,314,315,316,317,318,319, 320,321,322,323,324,325,326,327, 328,329,330,331,332,333,334,335, 336,337	25 041 06	12	Kit, governor linkage (Includes 13) (Use before Serial No. 2008000016) 336	82 755 07
11	Gasket, air cleaner 82	41 041 11	12	Kit, governor linkage (Includes 13) 41,45,46,51,52,74,79,81,316	82 755 06
12	Kit, governor linkage (Includes 13) 13,29,30,32,33,41,43,62,63,67,71, 75,76,78,87,88,300,301,302,303, 304,306,308,309,310,311,312,321, 322,323,324,325,326,327,330,331, 332	82 755 07	13	Bushing (Replaced by 25 158 11) 13,29,30,32,33,41,43,45,46,51,52, 62,63,67,71,74,75,76,78,79,81,86, 87,88,300,301,302,303,304,305, 306,308,309,310,311,312,314,315, 316,318,319,320,321,322,323,324, 325,326,327,328,330,331,332,333, 335,336	25 158 09
12	Kit, governor linkage 86,337 Before Serial No. 2121800016 use: After Serial No. 2121800006 use:	82 755 07 82 755 06	14	Arm, governor 13,29,30,32,33,41,43,45,51,56,62, 63,67,71,75,76,78,79,87,88,300, 301,302,303,304,305,306,308,309, 310,311,312,314,315,316,318,319, 320,321,322,323,324,325,326,327, 328,330,331,332,333,335,336	52 186 06
12	Kit, governor linkage (Includes 13) (Use before Serial No. 1822800016) 305	82 755 07	15	Washer, I.T. 1/4" 41,45,46,51,68,74,79,316	X-22-11

M18 & M20

Index Number	Description Variation Number	Part Number	Index Number	Description Variation Number	Part Number
15	Washer, I.T. 1/4" (Use after Serial No. 2121800006) 86,337	X-22-11	21	Kit, solenoid (Includes 19,20,22, terminals: 25 452 03, 25 452 07, 25 452 10, lead 41 518 18) (Use after Serial No. 2121800006) 86,337	25 755 06
15	Washer, I.T. 1/4" (Use after Serial No. 2129800006) 313	X-22-11	21	Kit, solenoid (Includes 19,20,22, terminals: 25 452 03, 25 452 07, 25 452 10, lead 41 518 18) (Use after Serial No. 2129800006) 313	25 755 06
15	Washer, I.T. 1/4" (Use after Serial No. 1735100006) 314	X-22-11	21	Kit, solenoid (Includes 19,20,22, terminals: 25 452 03, 25 452 07, 25 452 10, lead 41 518 18) (Use after Serial No. 1735100006) 314	25 755 06
15	Washer, I.T. 1/4" (Use after Serial No. 2002500006) 315	X-22-11	21	Kit, solenoid (Includes 19,20,22, terminals: 25 452 03, 25 452 07, 25 452 10, lead 41 518 18) (Use after Serial No. 2002500006) 315	25 755 06
15	Washer, I.T. 1/4" (Use after Serial No. 2112700006) 317	X-22-11	21	Kit, solenoid (Includes 19,20,22, terminals: 25 452 03, 25 452 07, 25 452 10, lead 41 518 18) (Use after Serial No. 2112700006) 317	25 755 06
15	Washer, I.T. 1/4" (Use after Serial No. 2014500006) 319	X-22-11	21	Kit, solenoid (Includes 19,20,22, terminals: 25 452 03, 25 452 07, 25 452 10, lead 41 518 18) (Use after Serial No. 2014500006) 319	25 755 06
15	Washer, I.T. 1/4" (Use after Serial No. 1924900006) 320	X-22-11	21	Kit, solenoid (Includes 19,20,22, terminals: 25 452 03, 25 452 07, 25 452 10, lead 41 518 18) (Use after Serial No. 1924900006) 320	25 755 06
15	Washer, I.T. 1/4" (Use after Serial No. 2130400006) 328	X-22-11	21	Kit, solenoid (Includes 19,20,22, terminals: 25 452 03, 25 452 07, 25 452 10, lead 41 518 18) (Use after Serial No. 2130400006) 328	25 755 06
15	Washer, I.T. 1/4" (Use after Serial No. 1735100006) 333	X-22-11	21	Kit, solenoid (Includes 19,20,22, terminals: 25 452 03, 25 452 07, 25 452 10, lead 41 518 18) (Use after Serial No. 1735100006) 333	25 755 06
15	Washer, I.T. 1/4" (Use after Serial No. 1825000006) 334	X-22-11	21	Kit, solenoid (Includes 19,20,22, terminals: 25 452 03, 25 452 07, 25 452 10, lead 41 518 18) (Use after Serial No. 1825000006) 334	25 755 06
16	Gasket 41,45,46,51,52,74,79,81,86,313, 314,315,316,319,320,328,333,335, 337	277180	21	Kit, solenoid (Includes 19,20,22, terminals: 25 452 03, 25 452 07, 25 452 10, lead 41 518 18) (Use after Serial No. 1924900006) 320	25 755 06
17	Screw, sltd. pan hd. 6-40x1/4" 41,45,46,51,52,74,79,81,86,313, 314,315,316,319,320,328,333,335, 337	52 086 15	21	Kit, solenoid (Includes 19,20,22, terminals: 25 452 03, 25 452 07, 25 452 10, lead 41 518 18) (Use after Serial No. 2130400006) 328	25 755 06
18	Bracket, solenoid 41,45,46,51,52,74,79,81,86,313, 314,315,316,319,328,333,335,337	52 126 13	21	Kit, solenoid (Includes 19,20,22, terminals: 25 452 03, 25 452 07, 25 452 10, lead 41 518 18) (Use after Serial No. 1735100006) 333	25 755 06
18	Bracket, solenoid (Discontinued not available at Kohler Co.) 53,68,317,334	52 126 04	21	Kit, solenoid (Includes 19,20,22, terminals: 25 452 03, 25 452 07, 25 452 10, lead 41 518 18) (Use after Serial No. 2003300006) 335	25 755 06
19	O-Ring 41,45,46,51,52,74,79,81,86,313, 314,315,316,319,320,328,333,337	52 153 01	21	Kit, solenoid (Includes 19,20,22, terminals: 25 452 03, 25 452 07, 25 452 10, lead 41 518 18) (Use after Serial No. 1905200006) 53	25 755 05
19	O-Ring 53,68,317,334,335	41 153 02			
20	Rod, plunger 41,45,46,51,52,74,79,81,86,313, 314,315,316,319,320,328,333,335, 337	52 411 07			
20	Rod, plunger 53,68,317,334	41 385 01			
21	Kit, solenoid (Includes 19,20,22, terminals: 25 452 03,25 452 07, 25 452 10, lead 41 518 18) 41,45,46,51,52,74,79,81,316	25 755 06			

**Carburetor
(Cont.)**

M18 & M20

Index Number	Description Variation Number	Part Number	Index Number	Description Variation Number	Part Number
21	Kit, solenoid (Includes 19,20, terminals: 25 452 03, 25 452 07, lead 41 518 18) 68	25 755 05	23	Kit, carburetor baffle (Includes 3 [qty. 2],11,24-27) (Use after Serial No. 2224300006) 88	82 755 24
21	Kit, solenoid (Includes 19,20, terminals: 25 452 03, 25 452 07, lead 41 518 18) (Use after Serial No. 2112700006) 317	25 755 05	24	Gasket, air cleaner 87,88	277093
21	Kit, solenoid (Includes 19,20, terminals: 25 452 03, 25 452 07, lead 41 518 18) (Use after Serial No. 1825000006) 334	25 755 05	25	Stud, 5/16-18x1-1/4" (2) 87,88	41 072 19
22	Connector 41,45,46,51,52,74,79,81,86,313, 314,315,316,319,320,328,333,335	25 155 08	26	Baffle, carburetor 87,88,337	52 063 40
23	Kit, carburetor baffle (Includes 3 [qty. 2],11,24-27) (Use after Serial No. 2224300006) 87	82 755 24	27	Plug, spark (RV17YC) 87,88	52 132 02
			28	Heater, thermistor 82	52 319 02
			29	Gasket, thermistor 82	52 041 22
			30	Line, fuel 4" 82	25 353 06
			31	Connector, straight 53,82	X-380-1
			32	Plug, hex. ctsk. 1/8" N.P.T.F. 74,84	X-75-23

M18 & M20

Carburetor (Cont.)

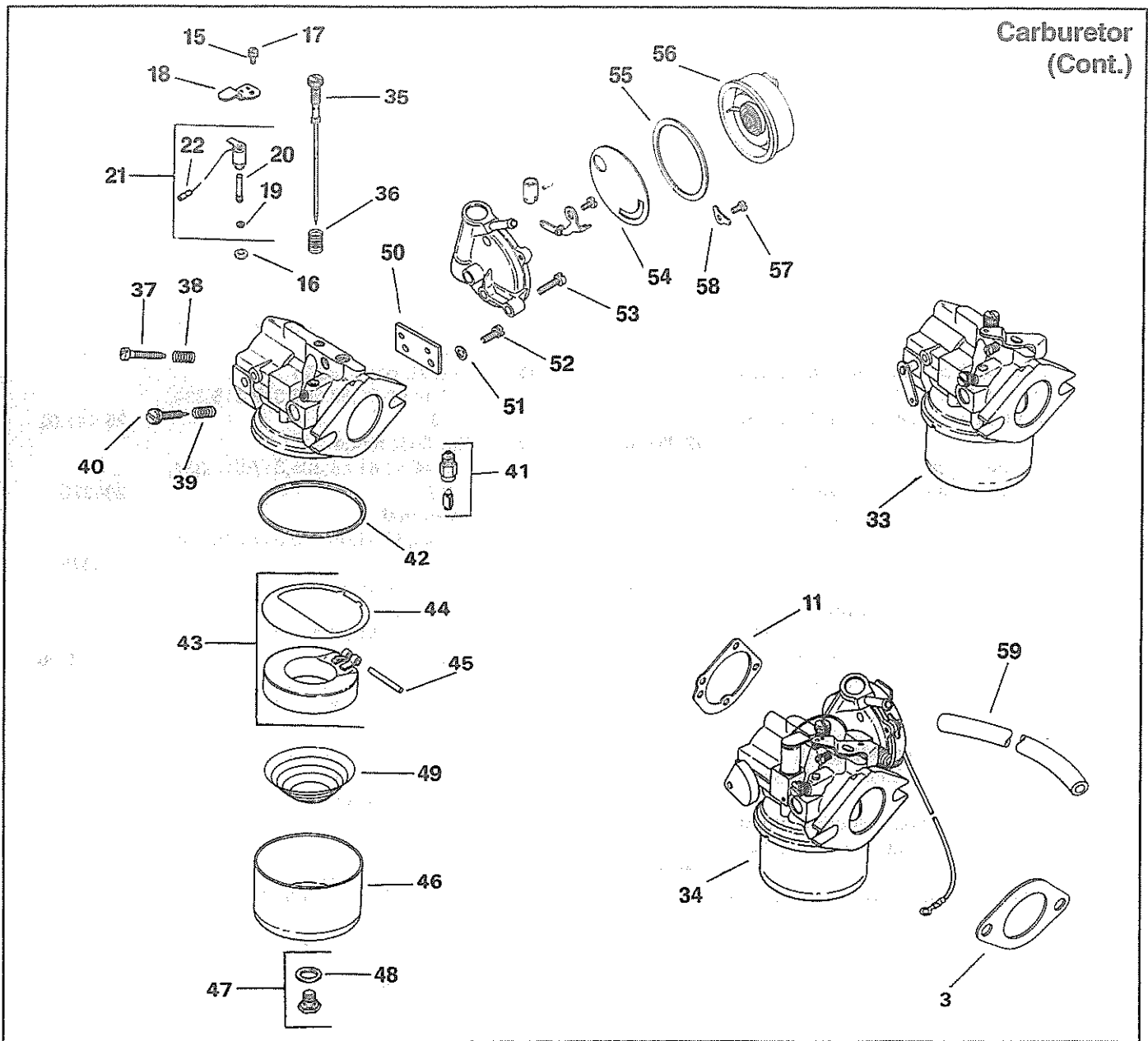

Index Number	Description Variation Number	Part Number	Index Number	Description Variation Number	Part Number
33	Carburetor assembly (Includes 35-49, Carburetor repair kit 25 757 02, T & C shaft repair kit 25 757 05)		34	Carburetor assembly (Includes 2,35-48,50-59, Carburetor repair kit 25 757 02) (Use before Serial No. 2112700016)	
	27	52 053 19		317	52 053 43
33	Carburetor assembly (Includes 35-49, Carburetor repair kit 25 757 02, T & C shaft repair kit 25 757 05)			After Serial No. 2112700006 use: Kit, adjustable jet carburetor (Includes 3,11, Carburetor assembly 52 053 60*, includes 2,18-20,35-48, 50-59, solenoid, Carburetor repair kit 25 757 02)	
	61	52 053 64			52 853 31
34	Carburetor assembly (Includes 2,35-48,50-59, Carburetor repair kit 25 757 02)				
	44	52 053 43			

**Carburetor
(Cont.)**

M18 & M20

Index Number	Description Variation Number	Part Number	Index Number	Description Variation Number	Part Number
34	Carburetor assembly (Includes 2,35-48,50-59, solenoid, Carburetor repair kit 25 757 02) (Use before Serial No. 1905200016) 53	52 053 43	41	Needle and Seat (Available only in Carburetor repair kit 25 757 02) 27,44,53,61,68,305,317,318,334, 336	
	After Serial No. 1905200006 use: Kit, adjustable jet carburetor (Includes 3,11, Carburetor assembly 52 053 60*, includes 2,18-20,35-48, 50-59, solenoid, Carburetor repair kit 25 757 02)	52 853 31	42	Gasket, bowl 27,44,53,61,68,305,317,318,334, 336	200375
34	Carburetor assembly (Includes 2,35-48,50-59, Carburetor repair kit 25 757 02) (Use before Serial No. 1825000016) 334	52 053 43	43	Kit, float (Includes 44) 27,44,53,61,68,305,317,318,334, 336	25 757 03
	After Serial No. 1825000006 use: Kit, adjustable jet carburetor (Includes 3,11, Carburetor assembly 52 053 60*, includes 2,18-20,34-48, 50-59, solenoid, Carburetor repair kit 25 757 02)	52 853 31	44	Gasket, bowl baffle 27,44,53,61,68,305,317,318,334, 336	25 041 02
34	Kit, adjustable jet carburetor (Includes 3,11, Carburetor assembly 52 053 60*, includes 2,18-20,34-48, 50-59, solenoid, Carburetor repair kit 25 757 02) 68	52 853 31	45	Pin, float hinge 27,44,53,61,68,305,317,318,334, 336	200376
35	Needle, main fuel adjusting 27,44,53,61,68,305,317,318,334, 336	52 103 01	46	Bowl, fuel 27,44,53,61,68,305,317,318,334, 336	235448
36	Spring, main fuel adjusting needle 27,44,53,61,68,305,317,318,334, 336	200383	47	Screw, bowl retainer (Includes 48) 27,44,53,61,68,305,317,318,334, 336	47 100 06
37	Spring, idle speed adjusting screw 27,44,53,61,68,305,317,318,334, 336	232555	48	Gasket, bowl retainer screw 27,44,53,61,68,305,317,318,334, 336	200372
38	Screw, idle speed adjusting 27,44,53,61,68,305,317,318,334, 336	232556	49	Spring, float support 27,61,305,336	237917
39	Spring, idle fuel adjusting needle 27,44,53,61,68,305,317,318,334, 336	200380	50	Bracket, choke 44,53,68,317,334	48 126 01
40	Needle, idle fuel adjusting 27,44,61,305,318,336	277210	51	Washer, lock #10 44,53,68,317,334	X-19-1
40	Needle, idle fuel adjusting 68	235006	52	Screw, F.H.M. 10-32x5/8" (2) 44,53,68,317,334	X-15-1
40	Needle, idle fuel adjusting 317	277210	53	Screw, F.H.M. 6-32x1/4" (2) 44,53,68,317,334	X-15-14
	Before Serial No. 2112700016 use:	277210	54	Plate, baffle 44,53,68,317,334	277297
	After Serial No. 2112700006 use:	235006	55	Gasket 44,53,68,317,334	277281
40	Needle, idle fuel adjusting 334	277210	56	Heater, choke 44,53,68,317,334	52 175 01
	Before Serial No. 1825100016 use:	277210	57	Screw, F.H.M. 8-32x1/4" (2) 44,53,68,317,334	X-14-6
	After Serial No. 1825000006 use:	235006	58	Retainer, choke heater 44,53,68,317,334	277275
			59	Line, fuel 3" 44,53,68,317,334	25 353 02

M18 & M20

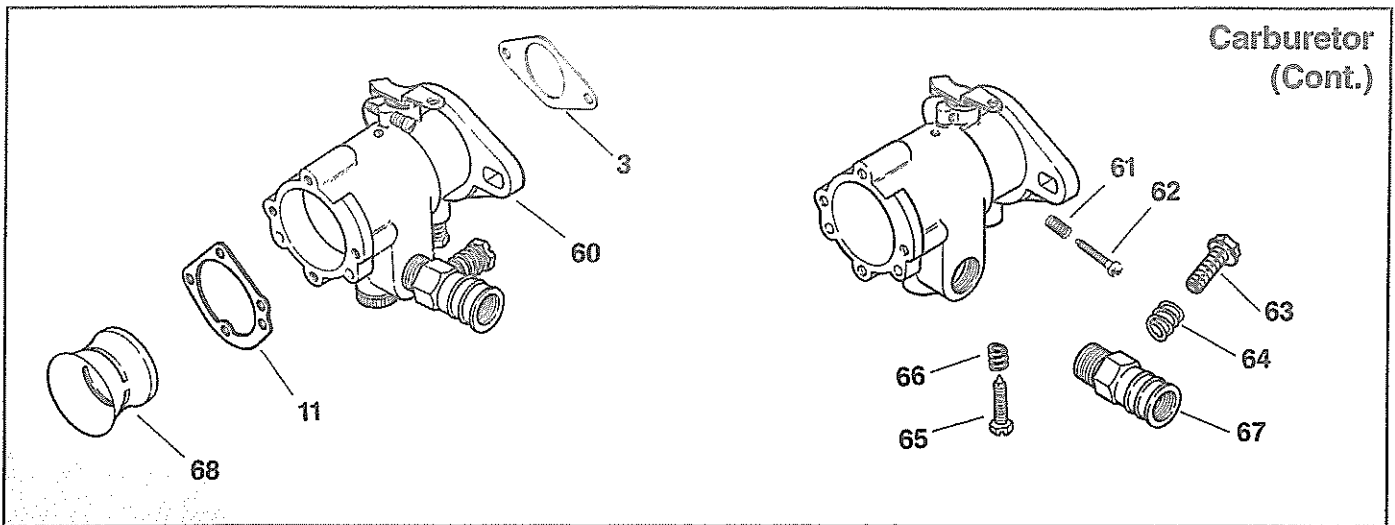

Index Number	Description Variation Number	Part Number	Index Number	Description Variation Number	Part Number
60	Carburetor assembly (Includes 62-68) (Use before Serial No. 1614300016) 307,329	52 053 23	Not Illustrated	Kit, carburetor repair 27,44,53,61,68,305,317,318,334,336	25 757 02
	After Serial No. 1614300006 or for complete carburetor replacement, use:			Kit, T & C shaft replacement 26,27,31,61,80,84,307,329,336	25 757 05
	Kit, carburetor (Includes 3,11, Carburetor assembly 52 053 30* or 52 053 25* - includes 62-68, T & C shaft repair kit 25 757 05)	52 853 06		Kit, T & C shaft replacement (Use after Serial No. 2008100006) 318	25 755 05
60	Carburetor assembly (Includes 62-69, T & C shaft repair kit 25 757 05) 80	52 053 67		Kit, T & C shaft replacement (Use after Serial No. 1822800006) 305	25 757 05
60	Kit, carburetor (Includes 3,11, Carburetor assembly 52 053 30* or 52 053 25* - includes 62-68, T & C shaft repair kit 25 757 05) 26,31,84	52 853 06		Lead, ground, black (10" - 18 gauge - uninsulated push on tab, insulated grip barrel eyelet) 41,81	52 518 05
61	Spring, idle speed adjusting screw 26,31,80,84,307,329	232555		Lead, ground, black (6" - 18 gauge - uninsulated push on tab, insulated grip barrel eyelet) 44,45,46,51,52,74,79,86,313,314,315,316,319,320,328,333,337	25 518 12
62	Screw, idle speed adjusting 26,31,80,84,307,329	232556		Lead, black (5" - 18 gauge) 41,45,46,51,52,53,68,74,79,81,86,313,314,315,316,317,319,320,328,333,334,335,337	41 518 18
63	Screw, idle fuel adjusting 26,31,80,84,307,329	52 086 13		Terminal 41,45,46,51,52,53,68,74,79,81,86,313,314,315,316,317,319,320,328,333,334,335,337	25 454 03
64	Screw, idle fuel adjusting 26,31,80,84,307,329	52 089 10		Terminal 41,45,46,51,52,53,68,74,79,81,86,313,314,315,316,317,319,320,328,333,334,335,337	25 452 07
65	Screw, load 26,31,80,84,307,329	52 086 14		Terminal 41,45,46,51,52,74,79,81,86,313,314,315,316,317,319,320,328,333,334,335,337	25 452 10
66	Spring, load screw 26,31,80,84,307,329	52 089 11			
67	Fitting, inlet 26,31,84,329	52 294 03			
67	Fitting, inlet 80	52 294 04			
68	Venturi 80	236666			

M18 & M20

Group 7 CRANKCASE

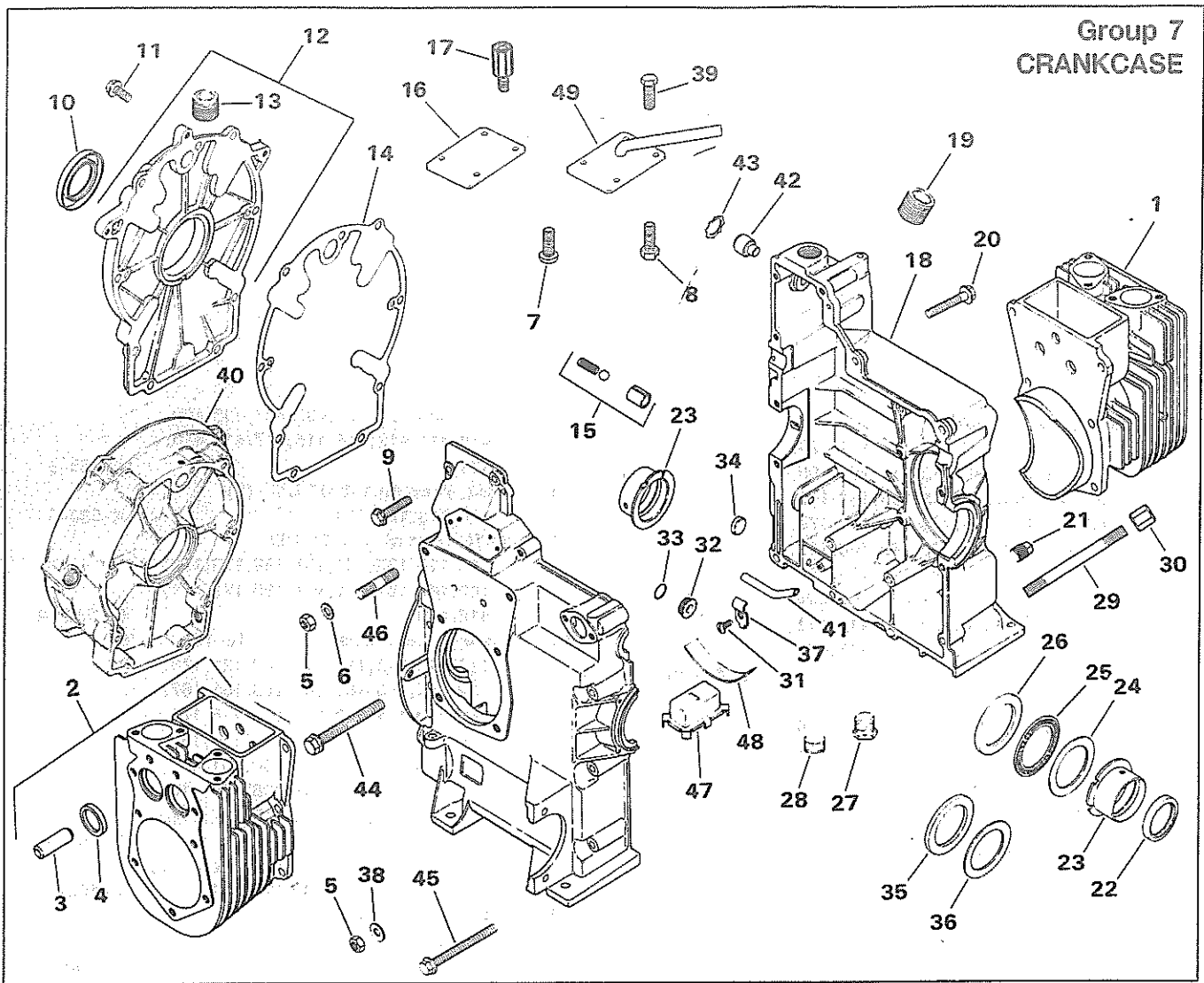

Index Number	Description Variation Number	Part Number	Index Number	Description Variation Number	Part Number
1	Kit, cylinder barrel #1 (Includes 3,4 and exhaust valve) 112,116,117,118,121,138,143,144, 157,160,162,164,165,167,175,176, 178,179,180,183,189,192,196,206, 207,400,401,402,403,404,405,406, 407,408,409,410,411	82 755 16	2	Kit, cylinder barrel #2 (Includes 3,4 and exhaust valve) 112,116,117,118,121,138,143,144, 157,160,162,164,165,167,175,176, 178,179,180,183,189,192,196,206, 207,400,401,402,403,404,405,406, 407,408,409,410,411	82 755 17
1	Kit, cylinder barrel #1 (Includes 3,4 and exhaust valve) 113,115,119,120,128,132,161,163, 166,168,169,171,172,173,181,182, 188,190,191,194,195,197,198,199, 200,412,413,414,415,416,417,418, 419,420,421	82 755 18	2	Kit, cylinder barrel #2 (Includes 3,4 and exhaust valve) 113,115,119,120,128,132,161,163, 166,168,169,171,172,173,181,182, 188,190,191,194,195,197,198,199, 200,412,413,414,415,416,417,418, 419,420,421	82 755 19
1	Barrel, cylinder #1 (Includes 3,4) 198	52 565 81	2	Barrel, cylinder #2 (Includes 3,4) 198	52 565 82
1	Barrel, cylinder #1 (Includes 3,4) 204	52 565 83	2	Barrel, cylinder #2 (Includes 3,4) 204	52 565 84

CRANKCASE
(Cont'd)

M18 & M20

Index Number	Description Variation Number	Part Number	Index Number	Description Variation Number	Part Number
3	Guide, valve (4) 112,113,115,116,117,118,119,120, 121,128,132,138,143,144,157,160, 161,162,163,164,165,166,167,168, 169,171,172,173,175,176,178,179, 180,181,182,183,188,189,190,191, 192,194,195,196,197,198,199,200, 204,206,207,400,401,402,403,404, 405,406,407,408,409,410,411,412, 413,414,415,416,417,418,419,420, 421	52 316 06	9	Screw, hex. flange 5/16-18 x 1-1/2" (9) 116,119,164,166	25 086 10
			9	Screw, hex. flange 5/16-18 x 1-1/2" (10) 157,188,421	25 086 10
			9	Screw, hex. flange 5/16-18 x 1-1/2" (12) 116,119,164,166	25 086 10
			10	Seal, rear oil 1-3/8" I.D. 112,113,117,118,120,121,128,144, 157,160,162,165,167,168,169,171, 172,175,176,178,180,188,192,195, 196,197,198,200,204,206,400,401, 402,403,404,405,406,407,408,409, 410,411,412,414,415,417,418,420, 421	X-583-5
4	Insert, valve seat (4) 112,113,115,116,117,118,119,120, 121,128,132,138,143,144,157,160, 161,162,163,164,165,166,167,168, 169,171,172,173,175,176,178,179, 180,181,182,183,188,189,190,191, 192,194,195,196,197,198,199,200, 204,206,207,400,401,402,403,404, 405,406,407,408,409,410,411,412, 413,414,415,416,417,418,419,420, 421	52 031 01	10	Seal, rear oil 1-3/8" I.D. (2) 116,119,164,166	X-583-5
			10	Seal, rear oil 1-1/2" I.D. 113,115,132,161,163,169,173,179, 182,183,189,190,191,195,196,413, 416,419	52 032 08
			11	Screw, hex. wash. hd. 5/16-18 x 1" (9) 112,113,115,117,118,120,121,128, 132,144,160,161,162,163,165,167, 168,169,171,172,173,175,176,178, 180,188,190,192,195,196,197,198, 199,200,204,206,207,400,401,402, 403,404,405,406,407,408,409,410, 411,412,413,414,415,416,417,418, 419,420	X-802-9
5	Nut, hex. 5/16-18 (12) 112,113,115,117,128,144,157,160, 161,162,163,164,165,166,167,168, 169,171,172,173,175,178,179,180, 181,182,183,188,189,190,191,192, 194,195,196,197,198,199,200,204, 206,207,400,401,402,403,404,405, 407,408,409,410,411,412,413,414, 415,416,417,418	X-82-2	11	Screw, hex. flange 5/16-18 x 1" (7) 179,181,182,183,189,191,194	X-802-9
5	Nut, hex. 5/16-18 (14) 113,116,118,119,120,121,128,132, 144,176,406,419,420,421	X-82-2	12	Kit, closure plate (Includes 13) 144,180,207	52 755 55
6	Washer, flat 5/16" (12) 112,113,115,116,117,118,119,120, 121,128,132,144,157,160,161,162, 163,164,165,166,167,168,169,171, 172,173,175,176,178,179,180,181, 182,183,188,189,190,191,192,194, 195,196,197,198,199,200,204,206, 207,400,401,402,403,404,405,406, 407,408,409,410,411,412,413,414, 415,416,417,418,419,420,421	52 468 12	12	Kit, closure plate (Includes 13) 115,117,118,120,162,163,165,169, 171,196,203,402,403,405,415,416	52 755 56
			12	Kit, closure plate 404,408 Before Serial No. 2130500016 use:	52 755 57
				After Serial No. 2130500006 use:	52 755 56
			12	Kit, closure plate (Includes 13) 112,113,128,160,161,172,175,190, 192,195,199,200,206,400,407,413, 418,419,420	52 755 57
7	Screw, hex. wash. hd. 1/4-20 x 5/8" (2) 198,204	52 086 11	12	Kit, closure plate 409,412 Before Serial No. 2005200016 use:	52 755 57
8	Screw, H.C. 1/4-20 x 1" 198,204	X-67-96		After Serial No. 2005200006 use:	52 755 56
9	Screw, hex. flange 5/16-18 x 1-1/2" (3) 112,113,115,117,118,120,121,128, 132,144,160,161,162,163,165,167, 168,169,171,172,173,175,176,178, 179,180,181,182,183,189,190,191, 192,194,195,196,197,198,199,200, 203,204,206,207,400,401,402,403, 404,405,406,407,408,409,410,411, 412,413,414,415,416,417,418,419, 420	25 086 10	12	Kit, closure plate (Includes 13) 132,173	52 755 58
			12	Kit, closure plate (Includes 13) 121,167,168,197,401,414	52 755 65
			12	Kit, closure plate (Includes 13) 176,406	52 755 69

M18 & M20

CRANKCASE
(Cont'd)

Index Number	Description Variation Number	Part Number	Index Number	Description Variation Number	Part Number
12	Kit, closure plate (Includes 13) 178 Before Serial No. 1712000016 use: After Serial No. 1712000006 use:	52 755 57 52 755 84	14	Gasket, closure plate (Used before Serial No. 1627600016 only) 118,120,402,403,405,415,416	52 041 15
12	Kit, closure plate (Includes 13) 179,182,183,189,191,194	52 755 99	14	Gasket, closure plate (Used before Serial No. 1628300013) 406	52 041 15
12	Kit, closure plate (Includes 13) 181	82 755 03	15	Kit, oil relief (Includes ball, spring & sleeve) 112,113,115,116,117,118,119,120, 121,128,132,144,157,160,161,162, 163,164,165,166,167,168,169,171, 172,173,175,176,178,179,180,181, 182,183,188,189,190,191,192,194, 195,196,197,198,199,200,204,206, 207,400,401,402,403,404,405,406, 407,408,409,410,411,412,413,414, 415,416,417,418,419,420,421	52 755 50
12	Kit, closure plate 417 Before Serial No. 1930000016 use: After Serial No. 1930000006 use:	52 755 57 52 755 56	16	Cover, crankcase 204	52 096 39
12	Kit, closure plate 421 Before Serial No. 1904400016 use: After Serial No. 1904400006 use:	52 755 69 82 755 14	17	Spacer 198,204	52 112 15
12	Kit, closure plate 411 Before Serial No. 2117600016 use: After Serial No. 2117600006 use:	52 755 56 52 755 84	18	Crankcase assembly (Service with a Short Block. Refer to M18-M20 Selection Guide TP-2253-C.)	
12	Kit, closure plate 157 Before Serial No. 2200900016 use: After Serial No. 2200900006 use:	82 755 14 52 009 52	19	Plug, pipe 1/16 x 27" N.P.T.F. 113,128,419	52 139 07
12	Kit, closure plate 410 Before Serial No. 1930300016 use: After Serial No. 1930300006 use:	52 755 57 52 755 56	20	Screw, hex. flange 5/16-18 x 2" (2) 112,113,115,116,117,118,119,120, 121,128,132,144,160,161,162,163, 164,165,166,167,168,169,171,172, 173,175,176,178,179,180,181,182, 183,192,194,197,198,199,200,204, 206,207,400,401,402,403,404,405, 406,407,408,409,410,411,412,413, 414,415,416,417,418,419,420	25 086 12
12	Kit, closure plate (Includes 9[Qty. 7],10,13,20,[Qty. 2], 52 009 52) 188	82 755 14	20	Screw, hex. flange 5/16-18 x 2" (4) 157,188,421	25 086 12
12	Kit, closure plate (Includes 9[Qty. 9],10[Qty. 2],13,14) 116,119,164,166	52 755 54	21	Plug, solid sq. hd. 3/8" N.P.T.F. 112,113,115,116,117,118,119,120, 121,128,132,144,157,160,161,162, 163,164,165,166,167,168,171,172, 173,175,176,178,179,180,181,182, 183,189,190,191,192,194,195,196, 197,199,206,400,401,402,403,404, 405,406,407,408,409,410,411,412, 413,414,415,417,418,419,420,421	X-75-10
13	Plug, hex. ctsk. 1/8" N.P.T.F. 112,113,115,116,117,118,119,120, 121,128,132,144,157,160,161,162, 163,164,165,166,167,168,169,171, 172,173,175,176,178,179,180,181, 182,183,188,189,190,191,192,194, 195,196,197,199,200,203,206,207, 400,401,402,403,404,405,406,407, 408,409,410,411,412,413,414,415, 416,417,418,419,420,421	X-75-23	22	Seal, front oil 112,113,115,116,117,118,119,120, 121,128,132,144,157,160,161,162, 163,164,165,166,167,168,169,171, 172,173,175,176,178,179,180,181, 182,183,188,189,190,191,192,194, 195,196,197,198,199,200,204,206, 207,400,401,402,403,404,405,406, 407,408,409,410,411,412,413,414, 415,416,417,418,419,420,421	52 032 10
14	Gasket, closure plate 116,119,164,166,198,204	52 041 15			
14	Gasket, closure plate (Used before Serial No. 1629000016 only) 175,178,400,404,407,408,409,413, 418,419,420	52 041 15			
14	Gasket, closure plate (Used before Serial No. 1626900016 only) 121,132,401,414	52 041 15			

CRANKCASE
(Cont'd)

M18 & M20

Index Number	Description Variation Number	Part Number	Index Number	Description Variation Number	Part Number
23	Bearing, sleeve flange (Std.) (2) 112,113,115,116,117,118,119,120, 121,128,132,144,157,160,161,162, 163,164,165,166,167,168,169,171, 172,173,175,176,178,179,180,181, 182,183,188,189,190,191,192,194, 195,196,197,198,199,200,204,206, 207,400,401,402,403,404,405,406, 407,408,409,410,411,412,413,414, 415,416,417,418,419,420,421	52 030 10	29	Nipple, pipe 200,207	12 136 07
23	Bearing, sleeve flange (.010) (2) 112,113,115,116,117,118,119,120, 121,128,132,144,157,160,161,162, 163,164,165,166,167,168,169,171, 172,173,175,176,178,179,180,181, 182,183,188,189,190,191,192,194, 195,196,197,198,199,200,204,206, 207,400,401,402,403,404,405,406, 407,408,409,410,411,412,413,414, 415,416,417,418,419,420,421	52 030 11	30	Cap, pipe 200,207	12 173 03
23	Bearing, sleeve flange (.020) (2) 112,113,115,116,117,118,119,120, 121,128,132,144,157,160,161,162, 163,164,165,166,167,168,169,171, 172,173,175,176,178,179,180,181, 182,183,188,189,190,191,192,194, 195,196,197,198,199,200,204,206, 207,400,401,402,403,404,405,406, 407,408,409,410,411,412,413,414, 415,416,417,418,419,420,421	52 030 12	31	Screw, hex. wash hd. 10-32 x 7/16" 112,113,115,116,117,118,119,120, 121,128,132,144,157,160,161,162, 163,164,165,166,167,168,169,171, 172,173,175,176,178,179,180,181, 182,183,188,189,190,191,192,194, 195,196,197,198,199,200,203,204, 206,207,400,401,402,403,404,405, 406,407,408,409,410,411,412,413, 414,415,416,417,418,419,420,421	X-67-64
24	Washer, thrust 112,118,120,175,197	52 468 09	32	Plug 3/4" O.D. 112,113,115,116,117,118,119,120, 121,128,132,144,157,160,161,162, 163,164,165,166,167,168,169,171, 172,173,175,176,178,179,180,181, 182,183,188,189,190,191,192,194, 195,196,197,198,199,200,204,206, 207,400,401,402,403,404,405,406, 407,408,409,410,411,412,413,414, 415,416,417,418,419,420,421	52 139 08
25	Bearing, thrust 118,120,175,197,206	52 030 13	33	O-Ring 112,113,115,116,117,118,119,120, 121,128,132,144,157,160,161,162, 163,164,165,166,167,168,169,171, 172,173,175,176,178,179,180,181, 182,183,188,189,190,191,192,194, 195,196,197,198,199,200,204,206, 207,400,401,402,403,404,405,406, 407,408,409,410,411,412,413,414, 415,416,417,418,419,420,421	52 141 02
26	Washer, thrust 118,120,175,206	52 114 04	34	Plug, cup 5/16" 112,113,115,116,117,118,119,120, 121,128,132,144,157,160,161,162, 163,164,165,166,167,168,169,171, 172,173,175,176,178,179,180,181, 182,183,188,189,190,191,192,194, 195,196,197,198,199,200,204,206, 207,400,401,402,403,404,405,406, 407,408,409,410,411,412,413,414, 415,416,417,418,419,420,421	X-702-15
27	Plug, bottom drain 3/8" N.P.T.F. 162,169,402,416	52 139 02	35	Spacer 206	52 112 17
28	Plug, hex. ctsk. 3/8" N.P.T.F. 119,157,164,166,188,204,421	X-75-32	36	Washer, thrust 206	52 468 19
28	Plug, hex. ctsk. 3/8" N.P.T.F. (2) 112,113,115,116,117,118,120,121, 132,144,160,161,162,163,165,167, 168,169,171,172,173,175,176,178, 179,180,181,182,183,190,191,192, 194,195,196,197,199,200,206,207, 400,401,402,403,404,405,406,407, 408,409,410,411,412,413,414,415, 416,417,418,419,420	X-75-32			

M18 & M20

CRANKCASE
(Cont'd)

Index Number	Description Variation Number	Part Number	Index Number	Description Variation Number	Part Number
37	Clamp, tube 112,113,115,116,117,118,119,120, 121,128,132,144,146,157,160,161, 162,163,164,165,166,167,168,169, 171,172,173,175,176,178,179,180, 181,182,183,188,189,190,191,192, 194,195,196,197,198,199,200,203, 204,206,207,400,401,402,403,404, 405,406,407,408,409,410,411,412, 413,414,415,416,417,418,419,420, 421	52 237 05	44	Screw, hex. flange 3/8-16 x 3-5/8" (2) 112,113,115,116,117,118,119,120, 121,128,132,144,157,160,161,162, 163,164,165,166,168,169,171,172, 173,175,176,178,179,180,181,182, 183,188,192,194,197,198,199,200, 204,206,207,400,401,402,403,404, 405,406,407,408,409,410,411,412, 413,414,415,416,417,418,419,420, 421	25 086 13
38	Washer, plain 5/16" (2) 113,116,118,119,120,121,128,132, 144,176,406,419,420,421	41 468 01	45	Screw, hex. flange 5/16-18 x 3-1/2" (8) 112,113,115,116,117,118,119,120, 121,128,132,144,157,160,161,162, 163,164,165,166,168,169,171,172, 173,175,176,178,179,180,181,182, 183,188,192,194,197,198,199,200, 204,206,207,400,401,402,403,404, 405,406,407,408,409,410,411,412, 413,414,415,416,417,418,419,420, 421	25 086 11
39	Screw, hex. socket hd. 5/16-18 x 1" (2) 179,181,182,183,189,191,194	25 086 17	46	Step stud 5/16-18 x 3/4", 3/8-16 x 5/8", 2" long (12) 112,113,115,116,117,118,119,120, 121,128,132,144,157,160,161,162, 163,164,165,166,168,169,171,172, 173,175,176,178,179,180,181,182, 183,188,189,190,191,192,194,195, 196,197,198,199,200,203,204,206, 207,400,401,402,403,404,405,406, 407,408,409,410,411,412,413,414, 415,416,417,418,419,420,421	52 072 12
40	Adapter, generator 198,204	52 029 20	47	Housing, oil strainer 112,113,115,116,117,118,119,120, 121,128,132,138,143,144,157,160, 161,162,163,164,165,166,167,168, 169,171,172,173,175,176,178,179, 180,181,182,183,188,189,190,191, 192,194,195,196,197,198,199,200, 204,206,207,400,401,402,403,404, 405,406,407,408,409,410,411,412, 413,414,415,416,417,418,419,420, 421	52 095 03
41	Tube, oil pickup 112,113,115,116,117,118,119,120, 121,128,132,144,157,160,161,162, 163,164,165,166,167,168,169,171, 172,173,175,176,178,179,180,181, 182,183,188,189,190,191,192,194, 195,196,197,198,199,200,203,204, 206,207,400,401,402,403,404,405, 406,407,408,409,410,411,412,413, 414,415,416,417,418,419,420,421	52 123 10	48	Clamp, spring 112,113,115,116,117,118,119,120, 121,128,132,138,143,144,157,160, 161,162,163,164,165,166,167,168, 169,171,172,173,175,176,178,179, 180,181,182,183,188,189,190,191, 192,194,195,196,197,198,199,200, 204,206,207,400,401,402,403,404, 405,406,407,408,409,410,411,412, 413,414,415,416,417,418,419,420, 421	52 237 02
42	Shaft, governor 112,113,115,116,117,118,119,120, 121,128,132,144,157,160,161,162, 163,164,165,166,167,168,169,171, 172,173,175,176,178,179,180,181, 182,183,188,189,190,191,192,194, 195,196,197,199,200,203,206,207, 400,401,402,403,404,405,406,407, 408,409,410,411,412,413,414,415, 416,417,418,419,420,421	52 078 05	49	Cover, crankcase 198	52 096 44
43	Ring, retaining 112,113,115,116,117,118,119,120, 121,128,132,144,157,160,161,162, 163,164,165,166,168,169,171,172, 173,175,176,178,179,180,181,182, 183,188,189,190,191,192,194,195, 196,197,199,200,203,206,207,400, 401,402,403,404,405,406,407,408, 409,410,411,412,413,414,415,416, 417,418,419,420,421	X-269-43			

M18 & M20

Group 8
CRANKSHAFT

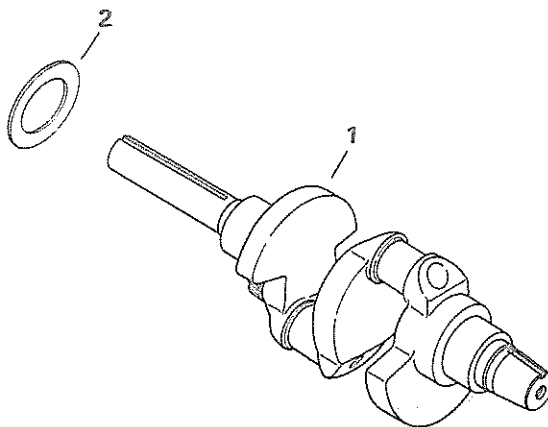

Index Number	Description Variation Number	Part Number	Index Number	Description Variation Number	Part Number
1	Crankshaft (1-1/8" dia. X 3-25/32" tapped P.T.O.) 80,145	52 014 63	1	Crankshaft M20 w/13 tooth spline (1-3/16" dia. X 1-1/16" P.T.O.) 110	52 014 89
1	Crankshaft (1-7/16" dia. X 4-29/64" tapped P.T.O.) 81	52 014 69	1	Crankshaft (1" dia. X 2-1/4" tapped P.T.O.) 112	52 014 82
1	Crankshaft (1-1/8" dia. X 2-37/64" tapped P.T.O.) 83	52 014 65	1	Crankshaft (1-1/8" dia. X 3-25/32" tapped P.T.O.) 114	52 014 86
1	Crankshaft (1-1/8" dia. X 2-51/64" tapped P.T.O.) 84	52 014 66	1	Crankshaft (1-9/32" dia. X 1-17/32" taper-tapped P.T.O.) 117	52 014 88
1	Crankshaft (1" dia. X 3-9/16" tapped P.T.O.) 85	52 014 64	1	Crankshaft (1-31/64" dia. X 2-7/16" tapped P.T.O.) 118	52 014 90
1	Crankshaft (1-1/8" dia. X 3-25/32" tapped P.T.O.) 92	52 014 76	1	Crankshaft (1-31/64" dia. X 2-13/32" tapped P.T.O.) 119	52 014 92
1	Crankshaft (1-1/4" dia. X 2-23/32" tapped P.T.O.) 93	52 014 71	1	Crankshaft M18 w/9 tooth spline (1-1/64" dia. X 2-9/16" P.T.O.) 121	52 014 99
1	Crankshaft (1" dia. X 2-15/16" tapped P.T.O.) 95	52 014 77	1	Crankshaft (1" dia. X 2-63/64" tapped P.T.O.) 123	82 014 03
1	Crankshaft (1-3/8" dia. X 3-51/64" taper-tapped P.T.O.) 99	52 014 80	1	Crankshaft M20 w/13 tooth spline (1-3/16" dia. X 1-1/16" P.T.O.) 124	52 014 98
1	Crankshaft (1-3/8" dia. X 3-51/64" taper-tapped P.T.O.) 100	52 014 83	1	Crankshaft M20 w/9 tooth spline (1-3/16" dia. X 1-1/16" P.T.O.) 125	52 014 96
1	Crankshaft (1" dia. X 4-5/64" thread P.T.O.) (Replaced by 52 142 04, Includes 1,2 and thrust bearing) 102	82 014 04	1	Crankshaft M18 w/13 tooth spline (1-1/64" dia. X 2-9/16" P.T.O.) 126	82 014 02
1	Crankshaft (1" dia. X 2-3/4" tapped P.T.O.) 103	52 014 79	1	Crankshaft M18 w/11 tooth spline (1-1/2" dia. X 2-9/16" P.T.O.) 127	82 014 01
1	Crankshaft (1-1/8" dia. X 3-25/32" tapped P.T.O.) 107	52 014 87	1	Crankshaft (7/8" dia. X 3-39/64" taper-tapped P.T.O.) 129	82 014 06

**CRANKSHAFT
(Cont'd)**

M18 & M20

Index Number	Description Variation Number	Part Number	Index Number	Description Variation Number	Part Number
1	Crankshaft (1" dia. X 3-3/16" tapped P.T.O.) 133	82 014 08	2	Washer, thrust .119/.122 (A.R.) 80,81,83,84,85,92,93,95,99,100, 102,103,107,110,112,114,117,118, 119,121,123,124,125,126,127,129, 133,134,135,136,137,138,140,141, 142,143,144	52 468 03
1	Crankshaft (1" dia. X 5-7/32" P.T.O.) 134	52 014 78	2	Washer, thrust .128/.131 80,81,83,84,85,92,93,95,99,100, 102,103,107,110,112,114,117,118, 119,121,123,124,125,126,127,129, 133,134,135,136,137,138,140,141, 142,143,144	52 468 04
1	Crankshaft (1-1/16" dia. X 1-23/32" taper-tapped P.T.O.) 135	82 014 11	2	Washer, thrust .137/.140 (A.R.) 80,81,83,84,85,92,93,95,99,100, 102,103,107,110,112,114,117,118, 119,121,123,124,125,126,127,129, 133,134,135,136,137,138,140,141, 142,143,144	52 468 05
1	Crankshaft (1-1/16" dia. X 1-23/32" taper-tapped P.T.O.) 87,136	82 014 10	NOT ILLUSTRATED		
1	Crankshaft (1-7/16" dia. X 2-5/16" tapped P.T.O.) 137	82 014 12		Kit, spline (Includes roll pin and insert) 121,125	82 755 02
1	Crankshaft (1-1/4" dia. X 1-9/64" P.T.O.) 138	82 014 16		Kit, spline (Includes roll pin and insert) 110,124,126	48 755 21
1	Crankshaft (1" dia. X 45/64" thread P.T.O.) 140	82 014 15		Kit, spline (Includes roll pin and insert) 127	48 755 23
1	Crankshaft (1" dia. X 3-23/64" thread P.T.O.) 141	82 014 13	Note: Crankshaft dimensions listed are for PTO end outside the cylinder block.		
1	Crankshaft (1-1/8" dia. X 2-25/32" tapped P.T.O.) 142	82 014 17			
1	Crankshaft (1" dia. X 3-1/4" tapped P.T.O.) 143	82 014 19			
1	Crankshaft (1" dia. X 3-1/4" tapped P.T.O.) 144	82 014 18			

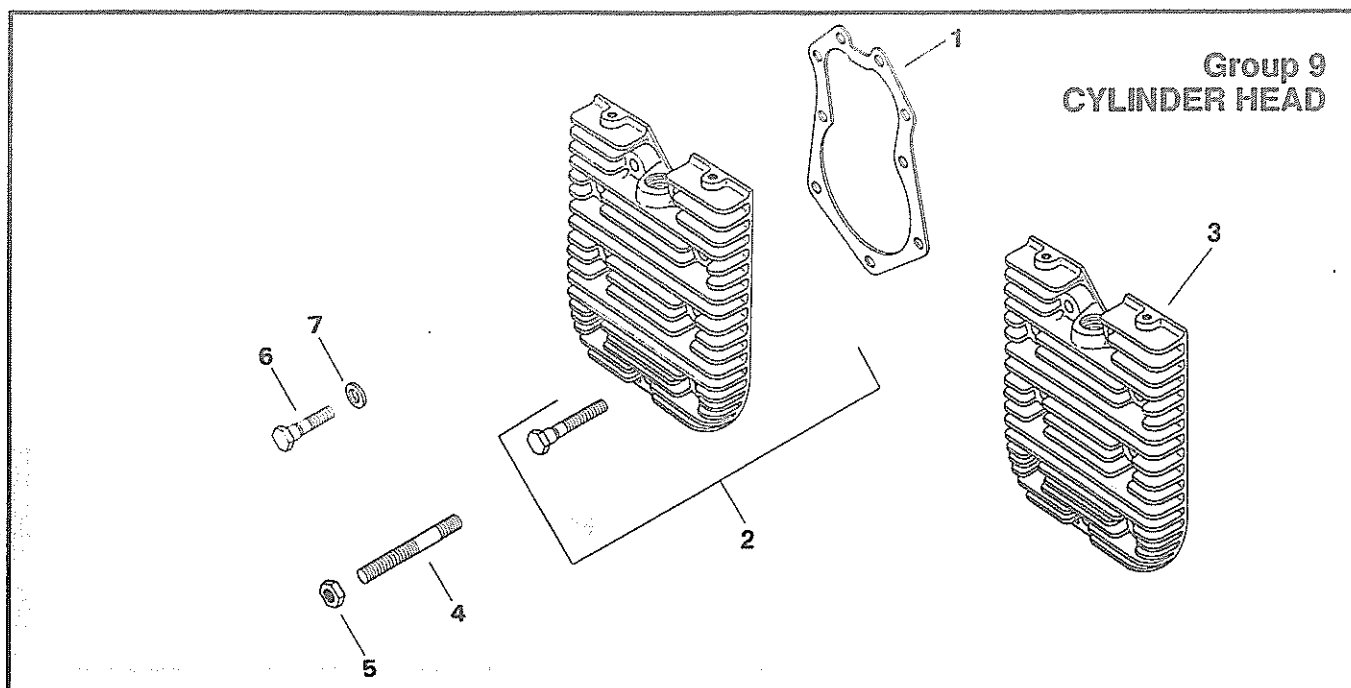

**Group 9
CYLINDER HEAD**

Index Number	Description Variation Number	Part Number	Index Number	Description Variation Number	Part Number
1	Gasket, cylinder head (2) 11, 14, 15, 18, 19, 20, 23, 26, 27, 28, 29, 30, 31	52 041 20	5	Nut, hex. 5/16"-18 (18) 23, 30	X-82-2
2	Kit, cylinder head (Includes screw 25 086 07 [qty.2]) 15, 19, 20, 27	52 755 78	6	Screw, hex. hd. 5/16-18X1-1/2" (8) 15, 19, 20, 27	41 086 02
3	Head, cylinder (2) 11, 14, 18, 23, 26, 29, 30	52 015 08	6	Screw, hex. hd. 5/16-18X1-1/2" (14) 29	41 086 02
3	Head, cylinder (2) 28	52 015 10	6	Screw, hex. hd. 5/16-18X1- 1/2" (17) 14, 18	41 086 02
3	Head, cylinder (2) 15, 19, 20, 27	52 755 78	6	Screw, hex. hd. 5/16-18X1- 1/2" (18) 11, 26, 28, 31	41 086 02
3	Head, cylinder (2) 31	52 015 12	6	Screw, hex. 5/16-18X2" 14, 18	25 086 07
4	Stud 5/16-18X3" (4) 29	232810	6	Screw, hex. 5/16-18X2" (4) 15, 27	25 086 07
4	Stud 5/16-18X2" (5) 19, 20	52 072 15	6	Screw, hex. 5/16-18X2" (5) 19, 20	25 086 07
4	Stud 5/16-18X2" (6) 15, 27	52 072 15	7	Washer, plain 5/16" (18) 11, 15, 20, 23, 26, 27, 28, 29, 30, 31	220534
4	Stud 5/16-18X2" (18) 23, 30	52 072 15	7	Washer, plain 5/16" (19) 14, 18, 19	220534
5	Nut, hex. 5/16"-18 (4) 29	X-82-2	NOT ILLUSTRATED		
5	Nut, hex. 5/16"-18 (5) 19, 20	X-82-2	Lead, switch to connector (20"-18 gauge-fully insulated push on tab) 14, 19		25 518 15
5	Nut, hex. 5/16"-18 (6) 15, 27	X-82-2	Harness, wiring 20		52 176 09

M18 & M20

Group 10
DIPSTICK

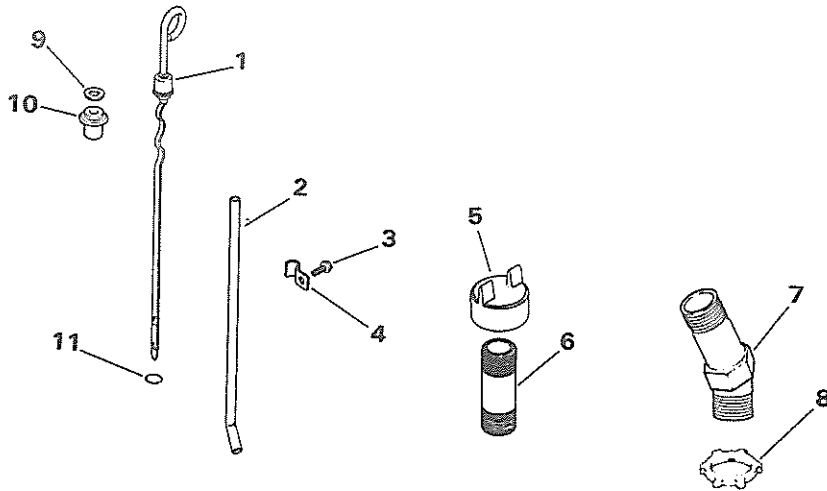

Index Number	Description Variation Number	Part Number	Index Number	Description Variation Number	Part Number
1	Dipstick 11-5/16" blade 13,14	52 038 04	5	Cap, pipe 13,14,20	52 173 01
1	Dipstick 11-5/16" blade 20	52 038 11	6	Pipe, oil fill 3/4 I.P. X2-1/2" 13,20	46 136 02
1	Dipstick assembly 11-5/16" blade (Includes 9,10) 25	52 038 20	7	Tube, oil fill 14	52 134 04
2	Tube, oil level 13,14,20	52 123 09	8	Nut, lock 3/4" 14	X-427-1
2	Tube, oil level 25	52 123 26	9	Washer, plain 21/64X9/16X1/16" 25	X-25-44
3	Screw, self-tapping 10-32X1/16" 13,14,20	X-67-64	10	Seal, rubber 25	52 032 14
4	Clip, tube 13,14,20	52 154 01	11	O-Ring 25	41 153 01

Group 11
ELECTRIC START

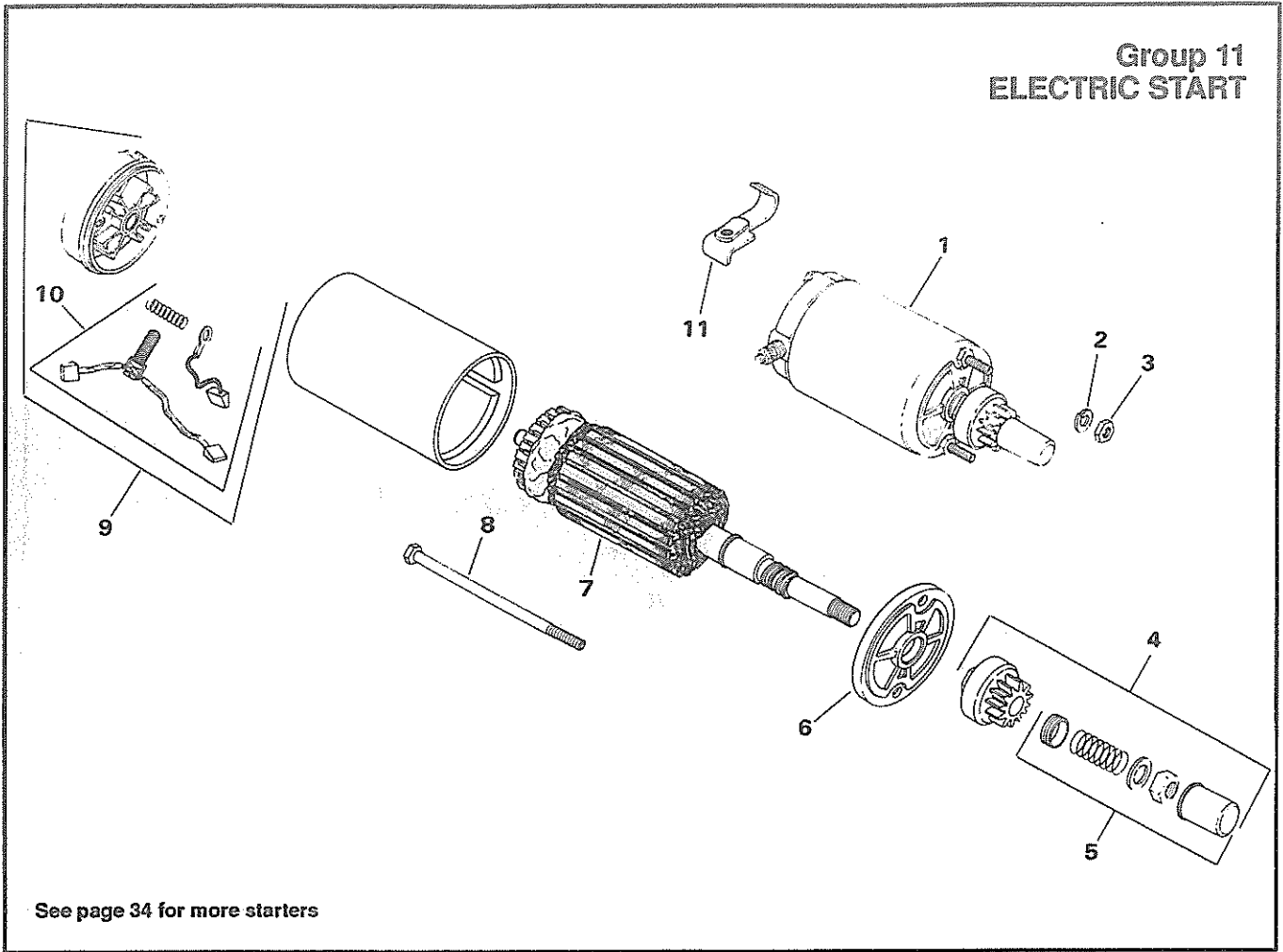

See page 34 for more starters

Index Number	Description Variation Number	Part Number	Index Number	Description Variation Number	Part Number
1	Starter assembly (Includes 4 thru 10) 1,9	52 098 03	7	Armature 1,9,10	52 170 02
1	Starter assembly (Includes 4 thru 10) 10	52 098 04	7	Armature 8,11	52 170 03
1	Starter assembly (Includes 4 thru 10) 8,11	52 098 06	8	Bolt, thru 1/4-20X5-7/8" (2) 1,9,10	52 211 01
2	Washer, split lock 1/4" (2) 1,8,9,10,11,14	X-20-1	8	Bolt, thru 1/4-20X6-7/8" (2) 8,11	52 211 03
3	Nut, hex 1/4"-20 (2) 1,8,9,10,11	X-81-1	9	Cap, commutator end assembly (Includes 10) 1,9	277612
4	Kit, drive (Includes 5) 1,8,9,10,11	52 755 05	9	Cap, commutator end assembly (Includes 10) 8,10,11	52 227 07
5	Kit, drive parts 1,8,9,10,11	52 755 08	10	Kit, brush & spring (Replaced by 52 755 15) 1,9	48 755 15
6	Cap, drive end 1,8,9,10,11	52 227 01	10	Kit, brush & spring 8,10,11	52 755 15
			11	Bracket, mounting 8	52 126 09

**Group 11
ELECTRIC START
(Cont'd)**

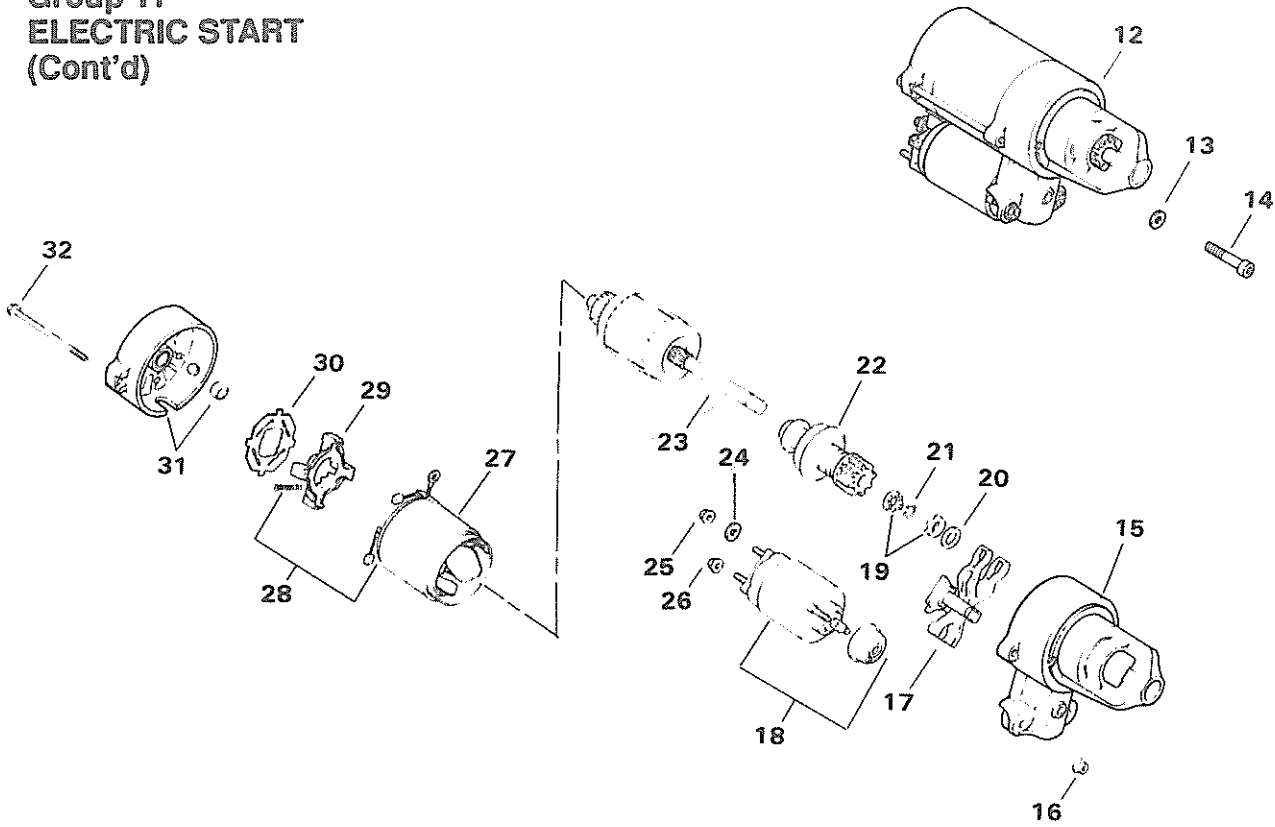

See page 33 for more starters

Index Number	Description Variation Number	Part Number	Index Number	Description Variation Number	Part Number
12	Starter assembly (solenoid shift) (Includes 15 thru 32)		24	Washer, spring 14	52 468 13
13	Washer, plain 17/64X1/2X1/16" (2) 14	52 098 08	25	Nut, hexagon 14	52 100 07
14	Screw, hex socket head cap 14	X-25-63 25 086 28	26	Nut 14	52 100 09
15	Cap, drive end 14	52 081 03	27	Frame 14	52 471 01
16	Nut (2) 14	52 100 10	28	Kit, brush & spring 14	52 221 01
17	Lever, drive 14	52 090 17	29	Holder, brush 14	52 323 03
18	Solenoid 14	52 435 02	30	Insulator 14	52 168 01
19	Nut, stop collar (2) 14	52 100 08	31	Cap, commutator end assembly 14	52 301 01
20	Washer, thrust 14	52 468 14	32	Bolt, thru 1/4"-20X4" (2) 14	52 211 05
21	Ring, retainer 14	52 141 03	NOT ILLUSTRATED		
22	Drive, pinion 14	52 239 01	Tag, caution 8,9,10,11,14		25 450 03
23	Armature 14	52 170 04	Lubricant, starter 1,8,9,10,11		52 357 01

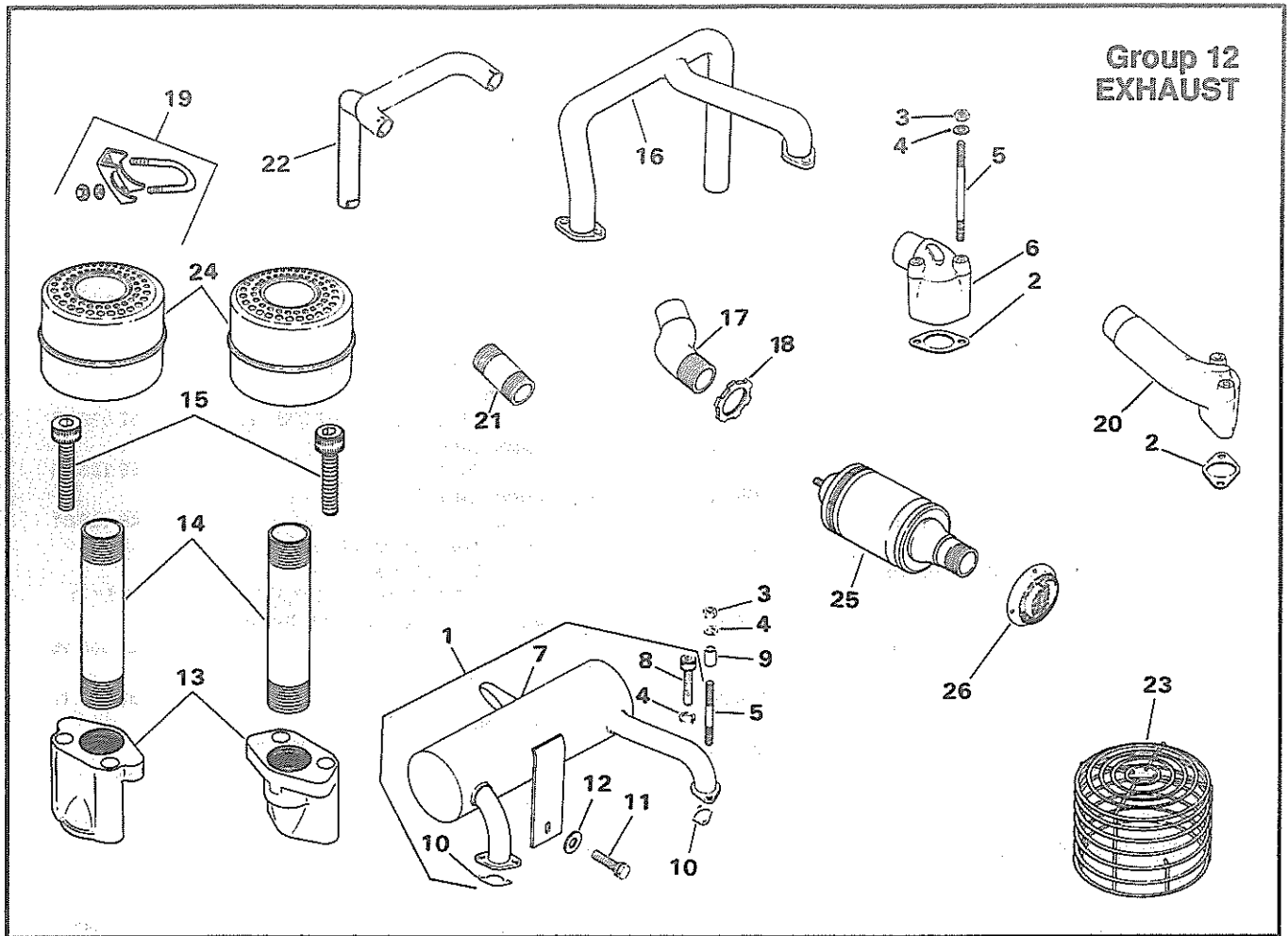

Index Number	Description Variation Number	Part Number	Index Number	Description Variation Number	Part Number
1	Kit, exhaust (Includes muffler, 4,8,10) 314	52 755 89	3	Nut, hex 5/16"-18 (4) (Used before Serial No. 1827300016) 402	X-82-2
1	Kit, exhaust (Includes muffler, 4,8,10,11,12) 22,25,39,311	52 755 87	4	Washer, lock 5/16" (4) 6,7,8,14,16,18,20,21,22,24, 25,27,29,31,34,39,40,41,42, 50,55,56,57,59,67,70,72,309, 310,311,313,314,315,402	X-21-1
1	Kit, exhaust (Includes muffler, 4,8,10,11,12) 31,59,313	52 755 88	4	Washer, lock 5/16" (4) (Used from Serial No. 1922300016 thru 2009500016) 401	X-21-1
1	Kit, exhaust (Includes muffler, 4,8,10,11,12) 21,24,315	52 755 86	4	Washer, lock 5/16" (4) (Used before Serial No. 1827300016) 402	X-21-1
2	Gasket, exhaust (2) 6,7,8,14,19,23,48,72,300,303,305, 307,308	52 041 10	5	Stud (2) 16,18,20,21,22,25,31,41,50, 56,57,70	52 072 13
2	Gasket, exhaust (2) (Used from Serial No. 192300016 thru 2009500016) 401	52 041 10	5	Stud (2) (Used from Serial No. 1922300016 thru 2009500016) 401	52 072 13
3	Nut, hex 5/16"-18 (2) 41,50,56,57,70	X-82-2	5	Stud (4) 6,7,16,21,72	52 072 13
3	Nut, hex 5/16"-18 (4) (Used from Serial No. 1922300016 thru 200950016) 401	X-82-2			

**EXHAUST
(Cont'd)**

M18 & M20

Index Number	Description Variation Number	Part Number	Index Number	Description Variation Number	Part Number
5	Stud (4) (Used before Serial No. 1827300016) 402	52 072 13	10	Gasket, exhaust (2) 16,18,20,21,22,24,25,27,29,31,34,39, 40,41,42,50,55,56,57,59,67,70,301,302, 304,309,310,311,313,314,315,402	52 041 14
5	Stud 8	25 072 21	11	Screw, H.C. sems 1/4-20X5/8" 16,18,20,21,22,24,25,27,31,39,41, 42,50,55,57,59,67,304,309,311,313,315	X-132-5
5	Stud 14,301	52 072 13	11	Screw, self-tapping 1/4-20X5/8" 20	52 086 11
6	Elbow, exhaust #2 side 7,8,14	52 054 06	12	Washer, plain 1/4" 16,18,20,21,22,24,25,27,31,39,41,42, 50,55,56,57,59,67,304,311,313,315	X-25-73
6	Elbow, exhaust #2 side 6,72	52 054 03	13	Adapter, exhaust (2) 8,19,23,48,300,305,307,308,312	52 029 13
6	Elbow, exhaust #2 side (Used from Serial No. 1922300016 thru 2009500016) 401	52 054 03	14	Nipple, pipe (2) 300,307,312	25 136 05
7	Muffler (3" cutaway extension) 16,27,309	52 068 05	14	Nipple, pipe (2) 308	48 136 01
7	Muffler (2-1/2" straight extension) 18,41,42	52 068 08	15	Screw, hex. socket hd. cap 5/16-18X2-1/4" (4) 19,23,48,300,305,307,308,312	X-55-9
7	Muffler (2-5/16" angled extension from left) 29	52 068 25	15	Screw, hex mach 5/16-18X3-1/8" 14	25 086 05
7	Muffler (2-5/16" angled extension from right) 29	52 068 26	16	Manifold 70	52 164 17
7	Muffler (2-1/2" straight extension) 41	52 068 28	16	Manifold (Use before Serial No. 1827300016) 402	52 164 17
7	Muffler (1-1/2" straight extension on left end) 55	52 068 34	17	Elbow (2) 23,48	231441
7	Muffler (2" straight extension) 56	52 068 40	18	Nut, lock (2) 23,48	AC-1536
7	Muffler (1-1/2" straight extension on left end) 57	52 068 44	19	Clamp, muffler (2) 10,72	237548
7	Muffler (2" straight extension, center-top) 67	52 068 39	19	Clamp, muffler (2) (Used from Serial No. 1922300016 thru 2009500016) 401	237548
7	Muffler (12" angled extension) 310	52 068 45	20	Elbow, exhaust #1 side 6,10,14,72	52 054 01
7	Muffler (3" cutaway extension) (Use before Serial No. 2103000016) 400	52 068 05	20	Elbow, exhaust #1 side 7,8	52 054 05
7	Muffler (Use after Serial No. 2013000016) 400	52 068 34	20	Elbow, exhaust #1 side (Used from Serial No. 1922300016 thru 2009500016) 401	52 054 01
7	Muffler (Used from Serial No. 1922300016 thru 2009500016) 401	52 068 04	21	Nipple (2) 48	41 136 04
8	Screw, hex. socket hd. cap 5/16-18X2-1/4" (2) 16,18,20,21,22,24,25,27,29,31,39, 40,41,42,50,55,56,57,59,67,70,304, 309,310,311,313,314,315	X-55-6	22	Tube, exhaust 72	52 123 25
8	Screw, hex. socket hd. cap 5/16-18X2-1/4" (2) (Use before Serial No. 1827300016) 402	X-55-6	23	Guard (2) 307	25 314 01
9	Spacer 2-1/4" long (2) 16,18,20,21,22,25,31,41,50,56,57,70	52 112 08	24	Muffler 8	52 068 04
9	Spacer 2-1/4" long (2) (Use before Serial No. 1827300016) 402	52 112 08	24	Muffler (2) 300,305,306,307,308	275679
			25	Muffler, spark arrestor 23	41 068 10
			26	Arrestor spark screen (2) 308	25 533 01

Group 13
FLYWHEEL

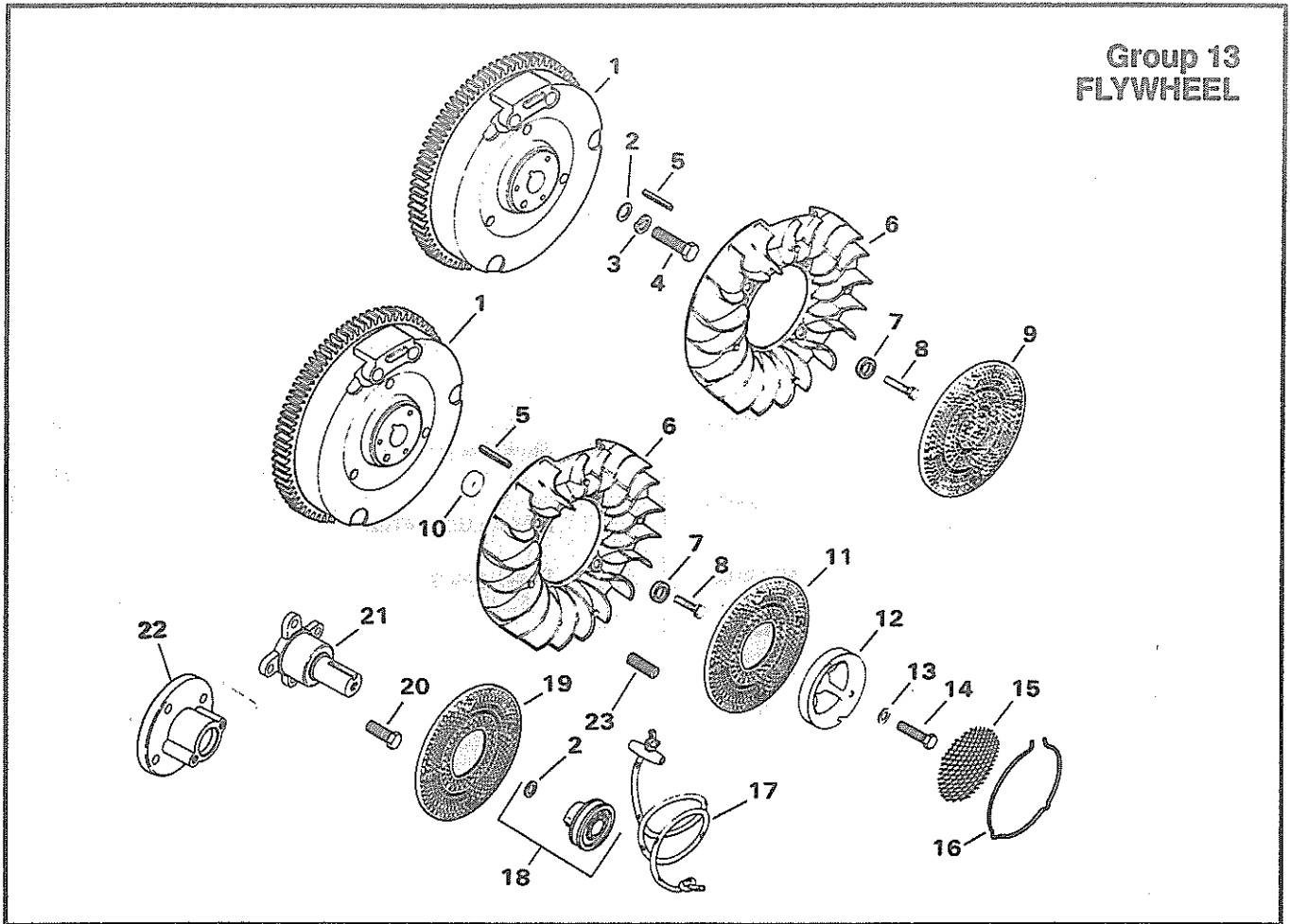

Index Number	Description Variation Number	Part Number	Index Number	Description Variation Number	Part Number
1	Flywheel 56,57,58,60,62,63,65,67,69, 70,71,74,76,78,80,300,301, 303,304	52 025 36	6	Fan 74	25 157 02
1	Flywheel 68,75,77,79,82	52 025 37	7	Spacer 1/8" (4) 56,57,58,60,62,63,65,67,68, 69,70,71,74,75,76,77,78,79,80,82, 300,301,302,303,304	25 112 04
2	Washer 56,57,58,60,62,63,65,67,68, 69,71,74,75,76,77,78,79,81,82, 301,302,303,304	52 468 15	8	Screw, hex. wash. hd. 1/4-20X5/8" (4) 56,57,58,60,62,63,65,67,68, 69,70,71,75,76,77,78,79,80,82, 300,301,302,303,304	25 086 21
3	Washer, lock 3/8" 70	X-22-1	9	Screen, grass 56,75	25 162 01
4	Screw 3/8-24X1-1/4" 56,57,58,60,62,63,65,67,68, 69,71,74,75,76,77,78,79,81,82, 301,302,303,304	25 086 24	9	Kit, metal grass screen (Includes 10 [qty. 2]) 74	82 755 20
5	Key, square 7/8X3/16X3/16" 56,57,58,60,62,63,65,67,68, 69,70,71,74,75,76,77,78,79,80, 81,82,300,302,302,303,304	X-286-17	10	Spacer 5/8" 66,80,300	52 112 09
6	Fan 56,57,58,60,62,63,65,67,68, 69,70,71,75,76,77,78,79,80,82,300, 301,302,303,304	25 157 01	10	Spacer (4) 74	52 112 14
			11	Screen, grass 3-1/2" dia. hole 57,60,69,70,71,78,80,82, 300,304	25 162 02
			12	Pulley, rope starting 80	47 093 01

**FLYWHEEL
(Cont'd)**

M18 & M20

Index Number	Description Variation Number	Part Number	Index Number	Description Variation Number	Part Number
13	Washer, plain 3/8" I.D., 1-1/4" O.D. 80,300	52 114 01	21	Shaft, front drive 65,77	235954
13	Washer, plain 17/64X3/4X1/16" 74	X-25-52	21	Shaft, front drive 67,76,79	52 144 19
14	Screw, 3/8-24X1-3/4" 70,80,300	25 086 25	21	Shaft, front drive (Not supplied by Kohler Co.- Contact Original Equipment Manufacturer)	
14	Screw, truss hd. nylok 1/4-20X5/8" (4) 74	47 086 08	21	Shaft, front drive 60	
15	Screen, grass 80,300	230098	21	Shaft, front drive 62	47 144 09
16	Retainer, screen 66,80,300	230363	22	Adapter, front drive 69	237373
17	Rope 300	A-230099	22	Adapter, front drive 78	52 029 19
18	Kit, drive cup (Includes 2) 57	52 755 61	23	Stud, hex (4) 74	52 072 21
19	Screen, grass 2-1/4" dia. hole 62,63,65,67,76,77,79,301, 302,303,304,	25 162 03		NOT ILLUSTRATED	
20	Screw, H.C. 3/8-16X1" (4) 60,62,65,67,69,76,77,78,79,304	X-159-2		Decal, pulley 80,300	25 113 06

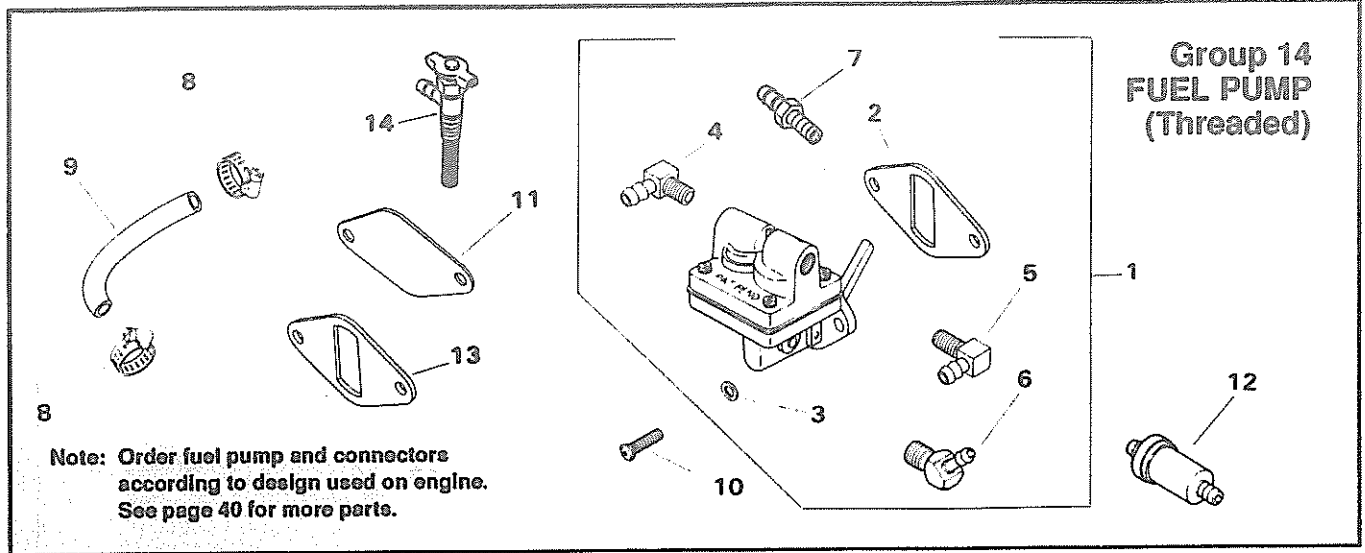

Index Number	Description Variation Number	Part Number	Index Number	Description Variation Number	Part Number
1	Pump, fuel assembly (w/threaded fittings) (Includes 2,3,4,5,6,7) 5,6,7,9,10,11,15,16,17,18,19,21,22, 25,30,31,49,51,300,301,302,303,304	52 559 01	8	Clamp, hose (2) 5,6,7,16,19,25,31,34,36,37, 300,301,303,304	X-426-9
1	Pump, fuel assembly (w/threaded fittings) (Includes 2,3,4,5,6,7) (Use before Serial No. 2026200016) 400	52 559 01	8	Clamp, hose 1/2" (4) 9,10,11,15,17,18,21,22,30,38, 39,49,51,52,53	X-426-9
2	Gasket, fuel pump 2,34,36,38,39,52,53	25 041 05	9	Line, fuel 1/4" I.D. X6-3/4" long 5,6,7,9,10,11,15,17,19,21,22, 25,30,31,34,36,37,38,39,49,51, 300,301,303,304	52 353 04
2	Gasket, fuel pump 5,6,9,10,11,15,16,17,18,19,21, 22,25,30,31,49,51,300,301,303,304	25 041 09	9	Line, fuel 1/4" I.D.X17" long 52,53	15 353 02
3	Washer (2) 5,6,7,8,9,10,11,15,16,17,18, 19,21,22,25,30,31,34,36,37,38, 39,49,51,300,302,303	X-25-63	9	Line, fuel 1/4" I.D.X3" long 9,11,15,18,22,34,39	25 353 02
4	Connector, 90° hose inlet (For 3/16" I.D. rubber hose) 19	X-391-11	9	Line, fuel 1/4" I.D.X4" long 31,49,50	25 353 06
4	Connector, 90° hose inlet (For 1/4" I.D. rubber hose) 25	45 155 01	9	Line, fuel 1/4" I.D.X7" long 10,38	25 353 14
5	Connector, 90° hose outlet (For 1/4" I.D. rubber hose) 5,7,9,10,15,16,18,19,22,25,31, 49,50,301,303,304	25 155 02	9	Line, fuel 1/4" I.D.X9" long 16,18,21,49	25 353 10
5	Connector, 90° hose outlet (2) (For 1/4" I.D. rubber hose) 6,11,17,21,30,300	25 155 02	9	Line, fuel 1/4" I.D.X10" long 52,53	52 353 20
6	Connector, 45° hose inlet (For 1/8" rubber hose) 9	X-274-8	9	Line, fuel 1/4" I.D.X13-1/4" long 17,30	25 353 03
7	Connector, straight (For 3/8" I.D. rubber hose) 5,7,9,10,15,16,18,22,31, 49,50,301,303,304	X-380-1	10	Screw, pozidriv T.H. 1/4-20X5/8" (2) 5,6,7,9,10,11,15,16,17,18,19, 21,22,25,30,31,34,36,37,38,39, 49,51,300,301,303,304	47 086 08
			10	Screw, sems hex H. 1/4-20X1/2" (2) 2,52,53,302	X-132-6
			11	Cover, fuel pump 2,302	240282
			11	Cover, fuel pump 52,53	52 096 42
			11	Cover, fuel pump assembly (Includes 5) (Use after Serial No. 2026200006) 400	52 096 46

**Group 14
FUEL PUMP
(Press-in)**

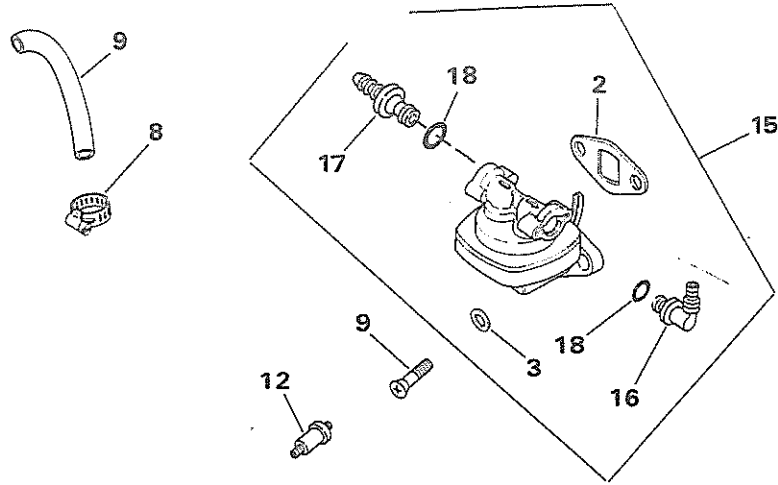

Note: Order fuel pump and connectors according to design used on engine. See page 39 for more parts.

Index Number	Description Variation Number	Part Number	Index Number	Description Variation Number	Part Number
12	Filter, fuel 9,10,11,17,22,51,52,303,304	25 050 02	15	Pump, fuel assembly (w/pressed in fittings) (Includes 2,3,16,17,18) (Replaced by 52 559 01) 34,36,37,38,39	52 559 02
12	Filter, fuel 15,18,21,30,31,39,49,300,301, 302	25 050 03	16	Connector, 90° press fit with O-ring 34,36,37,38,39	25 294 01
12	Filter, fuel (Replaced by 25 050 02) 34,38	25 050 01	17	Connector, straight with O-ring 34,36,37,38,39	25 294 03
13	Gasket, insulator 7,37	277649	18	O-ring (2) 34,36,37,38,39	25 153 01
14	Valve 304	220764			

M18 & M20

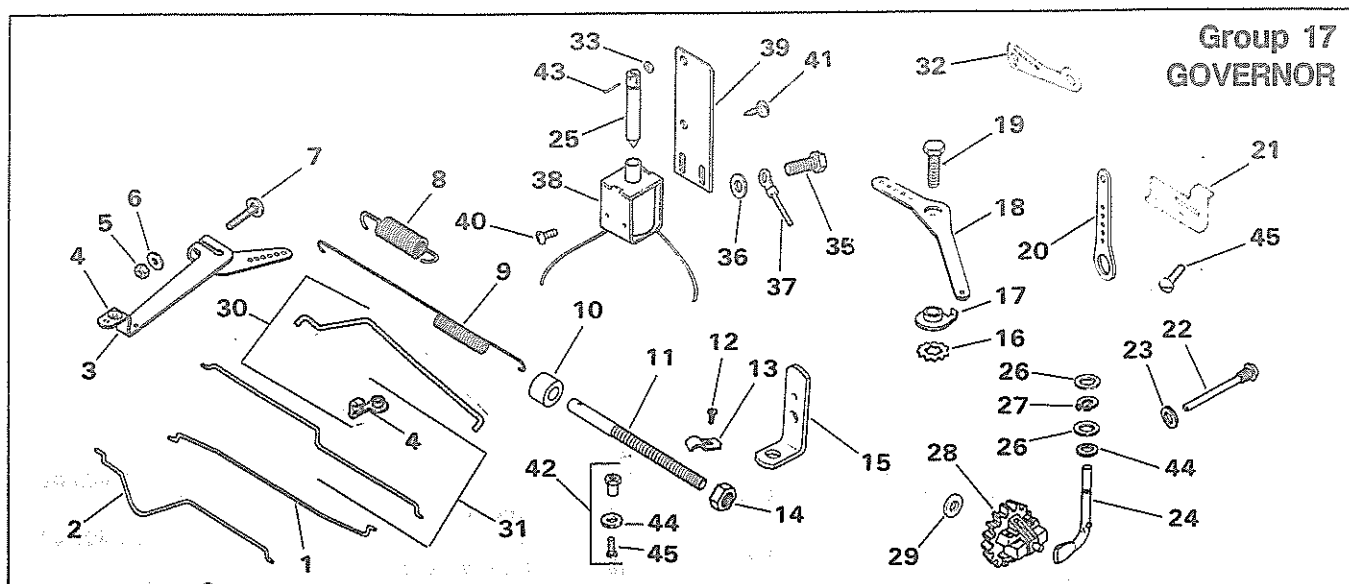

Index Number	Description Variation Number	Part Number	Index Number	Description Variation Number	Part Number
1	Kit, carburetor linkage (Includes 3,4 and linkage) 6,7,17	52 755 64	8	Spring, governor 6,10,21,22,30,31,37,38,40,41,42, 47,300	52 091 04
2	Kit, carburetor linkage (Includes 3,4 and linkage) Before Serial No. 1717400016 use: 400	52 755 64	8	Spring, governor 17	52 091 06
3	Arm, governor 10,21,22,23,24,26,30,31,32,33, 34,37,38,40,41,42,46,47,49,300	52 186 06	8	Spring, governor 17	230117
3	Arm, governor (Replaced by 52 755 64) (Includes 3,4 and linkage) 6,7,17	52 187 02	9	Spring, governor 7,10,23,24,26,32,33,34,46,49	52 091 05
4	Bushing, linkage (2) 33,34,42,46	25 158 08	10	Spacer 10,23,32,33,34,46	X-400-122
4	Bushing, linkage (2) (Replaced by 25 158 11) 7,10,21,22,23,24,26,30,31,32,37, 38,40,41,47,49,300	25 158 09	11	Rod, speed control 10,23,32,33,34,46	236258
4	Bushing, linkage (Replace by 25 158 11) Before Serial No. 1717400016 use: 400	25 158 09	12	Screw, hex. wash. hd. 10-24 x 3/8" (2) 6,7,10,17,21,22,23,24,26,30,31, 32,33,34,40,41,42,46,47,49,300	X-67-97
4	Bushing, linkage (2) After Serial No. 1717400006 use: (Install upside down) 400	25 158 08	12	Screw, hex. wash. hd. 10-24 x 3/8" (3) 37,38	X-67-97
5	Nut, hex. 1/4"-20 6,7,10,17,21,22,23,24,26,30,31, 32,33,34,37,38,40,41,42,46,47, 49,300	X-81-1	13	Clamp, cable 7,10,22,47	235778
6	Washer, plain 1/4" 6,7,10,17,21,22,23,24,26,30,31,32, 33,34,37,38,40,41,42,46,49,300	X-25-72	13	Clamp, cable (2) 6,7,17,21,23,24,26,30,31,32,33, 34,37,40,41,42,46,49	235778
7	Bolt, R.H. sq. neck 1/4-20 x 1" 6,7,10,17,21,22,23,24,26,30,31, 32,33,34,37,38,40,41,42,46,47,49, 300	52 211 04	13	Clamp, cable (3) 38	235778
			14	Nut, hex. 10-32 (2) 10,23,32,33,34,46	X-70-3
			15	Bracket, throttle cable 26,49	52 126 02
			16	Washer, I.T./E.T. 1/4" 6,7,24,26,30,42,46,49	X-22-12
			17	Stop, governor 6,7,22,24,26,30,31,37,38,40,41, 42,47,49,300	234614
			18	Lever, speed control 26,49	52 119 03'
			18	Lever, speed control 7,24,300	52 119 02
			19	Screw, H.C. 1/4-20 x 5/8" 7,24,26,49	X-5-1

GOVERNOR
(Cont'd)

M18 & M20

Index Number	Description Variation Number	Part Number	Index Number	Description Variation Number	Part Number
20	Lever, speed control 6,21,22,30,31,37,40,42,47,300	52 119 01	31	Kit, governor linkage (Includes 4)	
21	Stop, high speed 21,22,31,37,38,40,41,47	52 531 02	47		82 755 06
22	Pin, governor stop 6,7,10,17,21,22,23,24,26,30,31, 32,33,34,37,38,40,41,42,46,47,49, 300	231355	32	Lever, throttle and choke control 38,41	47 090 05
23	Washer, plain 1/4" 6,7,10,17,21,22,23,24,26,30,31, 32,33,34,37,38,40,41,42,47,49,300	X-25-12	33	Washer, plain 1/4" (2) 32,34,46	X-25-52
24	Shaft, governor 6,7,10,17,21,22,23,24,26,30,31,32, 33,34,37,38,40,41,42,46,47,49,300	52 078 04	34	Bracket, solenoid 32,34,46	52 126 18
25	Plunger 32,34,36	25 385 01	35	Screw, hex. mach. 8-32 x 1/4" (4) 32,34,46	41 086 20
26	Washer, plain 1/4" 6,7,10,17,21,22,23,24,26,30,31, 32,33,34,37,38,40,41,42,46,47, 49,300	X-25-63	36	Washer, plain (4) 32,34,46	25 468 02
27	Retainer, governor 6,7,10,17,21,22,23,24,26,30,31, 32,33,34,37,38,40,41,42,46,47, 49,300	X-269-28	37	Terminal 46	25 452 02
28	Kit, governor gear (Includes 29) 6,7,10,21,22,23,24,26,30,31,32, 33,34,36,37,38,40,41,42,47,49, 300,400	A-235743-S	38	Solenoid, idle (Includes 25) 32,34,46	47 435 01
28	Gear, governor 17	52 042 03	39	Screw, hex. wash. hd. 1/4-20 x 7/16" 37	X-67-83
29	Washer, thrust 6,10,17,21,22,23,24,26,30,31,32, 33,34,37,38,40,41,42,46,47,49	237022	40	Screw, hex. wash. hd. 1/4-20 x 5/8" 6,30,42	52 086 11
30	Link, governor 33,34,42,46	52 079 11	40	Screw, hex. wash. hd. 1/4-20 x 5/8" (2) 32,34,46	52 086 11
31	Kit, governor linkage (Includes 4) 31,47	82 755 06	41	Bracket, extension 37	52 126 16
31	Kit, governor linkage (Includes 4) 10,21,22,23,24,26,30,32,37,38,40, 41,49,300	82 755 07	42	Kit, clamp (Includes 44,45 and clamp) 38,41	48 755 10
31	Kit, governor linkage (Includes 4) 401 Before Serial No. 2002500016 use: After Serial No. 2002500006 use:	82 755 07 82 755 06	43	Pin, roll 32,34,46	X-280-25
31	Kit, governor linkage (Includes 4) 400 After Serial No. 1717400006 use:	82 755 07	44	Washer, plain 1/4" (2) 6,10,17,21,22,23,24,26,30,31, 32,33,34,37,40,41,42,46,47,49, 300	X-25-102
			44	Washer, plain 1/4" (3) 38	X-25-102
			44	Washer, plain 1/4" 7	X-25-102
			45	Screw, sltd. pan hd. 8-32 x 1/4" 7,38,41	X-51-8
			45	Screw, hex. wash. hd. 1/4-20 x 3/4" 21,22,31,37,38,40,300	X-67-62

M18 & M20

Group 18 Ignition

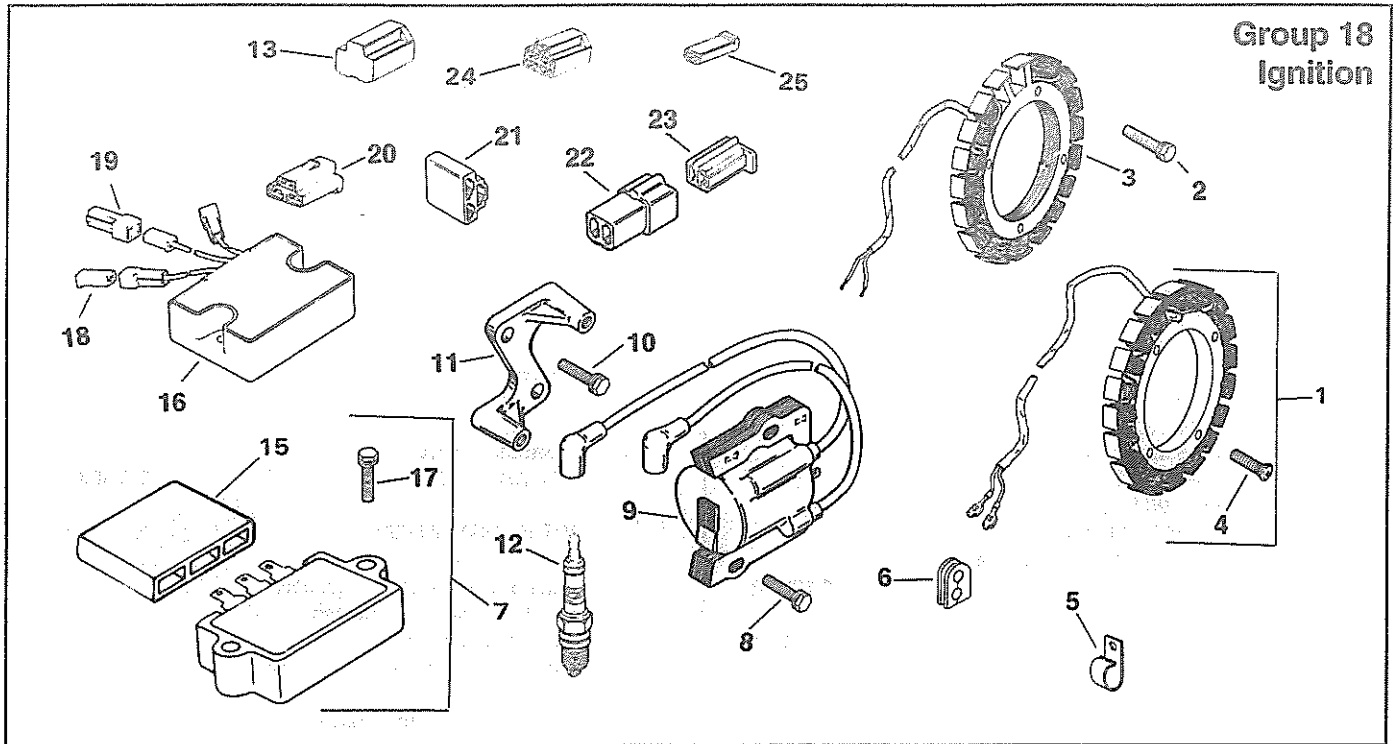

Index Number	Description Variation Number	Part Number	Index Number	Description Variation Number	Part Number
1	Kit, stator (15 amp) (Includes 4 and terminal 25 452 01) 16,18,19,23,29,31,33,44,46,49,51, 53,57,58,64,67,68,73,76,77,81,82, 83,84,90,91,92,95,97,98,100,101, 103,104,107,108,109,122,123,124, 300,301,303,304	237878	5	Clip, lead 16,83,103,123,124	48 154 02
1	Kit, stator (15 amp) (Includes 4 and terminal 25 452 01) (Use before Serial No. 1908900016) 93	237878	6	Grommet 16,18,19,23,27,29,30,31,33,34,44, 46,49,51,53,54,57,58,64,67,68,69, 73,76,77,81,82,84,90,91,92,93,95, 96,97,98,100,101,103,104,106,107, 108,109,110,119,122,123,124,300, 301,303,304	52 313 02
2	Screw, hex. wash. hd. 10-24x3/4" (4) 16,18,19,23,29,31,33,46,49,51,53, 57,58,64,67,68,73,76,77,81,82,84, 90,91,92,95,97,98,100,103,104, 107,108,109,123,124,300,304	X-67-51	7	Kit, rectifier-regulator, 15 amp (Includes 17) 16,18,19,23,29,31,33,46,49,51,53, 57,58,64,67,68,73,76,77,81,82,84, 90,91,92,95,97,98,100,103,104,107, 108,109,123,124,300,303,304	25 755 03
3	Stator (25 amp) (Replaced by 25 755 07) 27,30,34,54,69,96,106,110,119	25 085 05	8	Screw, hex. wash. hd. 1/4-20x1" (2) 16,18,19,23,27,29,30,31,33,34,44, 46,49,51,53,54,57,58,64,67,68,69, 73,76,77,81,82,83,84,90,91,92,93, 95,96,97,98,100,101,103,104,106, 107,108,109,110,119,122,123,124, 300,301,303,304	25 086 15
3	Kit, stator (25 amp) (Includes 4,18 [qty. 2], terminal 25 452 06) 27,30,34,54,69,96,106,110,119,302	25 755 07	9	Module 16,18,19,23,27,29,30,31,33,34,44, 46,49,51,53,54,57,58,64,67,68,69, 76,77,81,82,83,84,90,91,92,93,95, 96,97,98,100,101,103,104,106,107, 108,109,110,119,122,123,124,300, 301,302,303,304	52 584 02
3	Kit, stator (25 amp) (Includes 4,18 [qty. 2], terminal 25 452 06) (Use after Serial No. 1908900006) 93	25 755 07			
4	Screw, hex. wash. hd. 10-24x1" (4) 27,30,34,54,69,93,96,106,110, 119,302	25 086 29			

**IGNITION
(Cont'd)**

M18 & M20

Index Number	Description Variation Number	Part Number	Index Number	Description Variation Number	Part Number
9	Module 73	52 584 03	21	Connector, female (3 contact) 16,49,51,54,58,69,76,82,90, 91,93,95,96,97,98,103,108, 123,124	236473
10	Screw, hex head 1/4-20X1" (2) 16,18,19,23,27,29,30,31,33, 34,44,46,49,51,53,54,57,58, 64,67,68,69,73,76,77,81,82, 83,84,90,91,92,93,95,96,97, 98,100,101,103,104,106,107, 108,109,110,119,122,123,124, 300,301,302,303,304	25 086 16	22	Connector, female (2 contact) 19,27,29,57,67,68,73,92,106, 107,300,304	52 155 04
11	Bracket, module 16,18,19,23,27,29,30,31,33, 34,44,46,49,51,53,54,57,58, 64,67,68,69,73,76,77,81,82, 84,90,91,93,92,95,96,97, 98,100,101,103,104,106,107, 108,109,110,119,122,123,124, 300,301,302,303,304	52 126 08	23	Connector, male (2 contact) 19,27,29,46,53,57,67,68,73, 92,96,100,106,107,119,300,304	41 155 03
11	Bracket, module 83	52 126 21	24	Connector, female (5 contact) 30,33,109	48 155 01
12	Spark plug (RV17YC) (2) 16,18,23,27,29,31,33,34,44, 46,49,51,53,54,57,58,69,73, 76,77,81,82,84,119,122,123	52 132 02	25	Connector, female 44,101,301,303	277563
12	Spark plug (RV15YC) (2) 19,30,64,67,68,83,90,91,92,93,95, 96,97,98,100,101,103,104,106, 107,108,109,110,124,303,304	51 132 02	NOT ILLUSTRATED		
13	Connector 54,76,91,96	237088		Lead, black, rectifier-regulator (5" - 14 gauge - uninsulated push on tab terminals) 23,29,31,46,64,68,73,76,91,92, 100,107,108,109	25 518 05
13	Connector (Use before Serial No. 2006000016) 400	237088		Lead, black, rectifier-regulator (5" - 14 gauge - uninsulated push on tab terminals) (Use before Serial No. 2121800016) 124	25 518 05
15	Connector, female (3 contact) 16,18,19,23,29,31,33,46,49,51,53, 57,58,64,67,68,73,76,77,81,82,84, 90,91,92,95,97,98,100,103,104,107, 108,109,123,124,300,304	236602		Lead, black, rectifier-regulator (5" - 14 gauge - uninsulated push on tab terminals) 16,19	25 518 10
16	Regulator-rectifier, 25 amp. 27,30,34,54,69,96,106, 110,119,302	25 403 01		Lead, white, module to connector (27" - 14 gauge - insulated) 16,19,77,103,123,124	52 518 16
16	Regulator-rectifier, 25 amp. (Use after Serial No. 1908900006) 93	25 403 01		Lead, black rectifier-regulator (5" - 14 gauge - uninsulated push on tab terminals) (Use before Serial No. 2121800016) 123	25 518 10
17	Screw, H.C. sems 1/4-20X5/8" (2) 16,18,19,23,27,29,30,31,33,34, 46,49,51,53,54,57,58,64,67,68, 69,73,76,77,81,82,84,90,91,92, 93,95,96,97,98,100,103,104,106, 107,108,109,110,119,123,124,300, 302,304	X-132-5		Lead, violet, rectifier-regulator (15" - 14 gauge - uninsulated push on tab terminals) 18,57,67,81,104	41 518 27
18	Connector, receptacle 27,30,54,69,93	25 155 04		Lead, red, rectifier-regulator (3" - 13 gauge - uninsulated push on tab terminals) 27,30,54,69,77,93,103,106,119	52 518 10
18	Connector, receptacle (2) 34,96,106,110,119,302,304	25 155 04		Lead, black, module to connector (27" - 14 gauge - insulated push on tab - uninsulated push on tab) 53,58,95	52 518 22
19	Connector, tab 27,30,54,69,93,96,106,119, 302,304	25 155 03		Lead, red, rectifier-regulator (12" - 18 gauge - insulated push on tab - uninsulated push on tab) 53,58,95	52 518 21
20	Connector, female (3 contact) 23,84	52 155 06			

M18 & M20

Ignition
(Cont.)

Index Number	Description Variation Number	Part Number	Index Number	Description Variation Number	Part Number
	Lead, white, module to connector (22" - 14 gauge - insulated push on tab - uninsulated push on tab)			Terminal	
	67	52 518 24		27,30,34,54,69,93,96,106,110, 119,302	25 452 06
	Lead, white, module to connector (12-1/2" - 14 gauge - insulated push on tab - uninsulated push on tab)			Harness, wiring	
	23,27,29,30,31,33,44,46,49,51,54, 64,69,73,76,82,84,91,92,93,96,97, 98,100,101,106,107,108,109,119	52 518 17		68	52 176 10
	Terminal			Harness, wiring	
	16,18,19,23,29,31,33,44,46,49,51, 53,57,58,64,67,68,73,76,77,81,82, 83,84,90,91,92,95,97,98,100,101, 103,104,107,108,109,122,123,124, 300,301,303,304	25 452 01		51,82,84,90,97	52 176 06
				Harness, wiring (Use after Serial No. 2006000006)	
				400	52 176 06
				Harness, wiring	
				49,98,301,303	52 176 05
				Harness, wiring	
				123,124	
				Before Serial No. 2121800016 use:	52 176 12
				After Serial No. 2121800006 use:	52 176 08
				Harness, wiring	
				54,96	52 176 08

M18 & M20

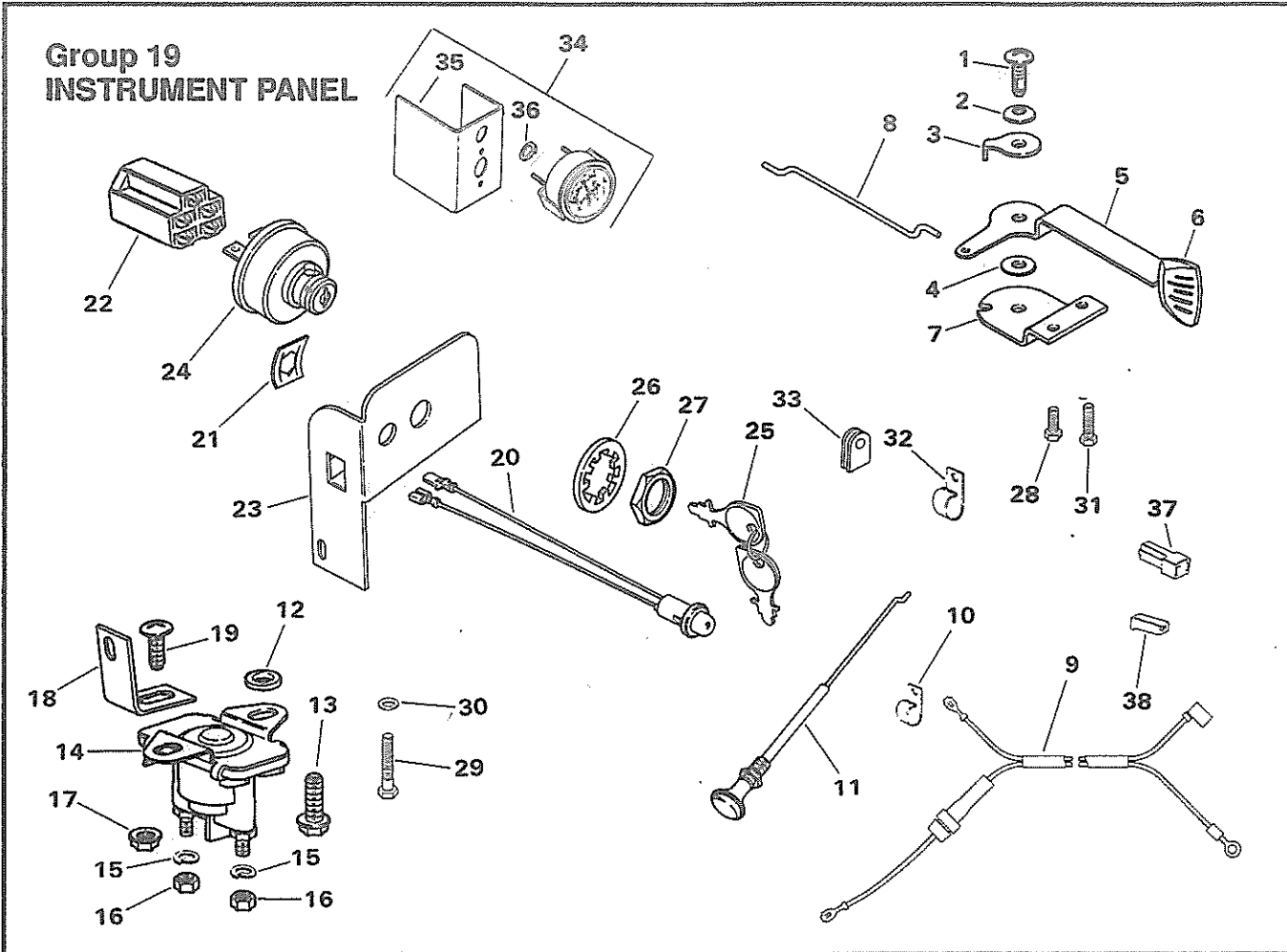

Index Number	Description Variation Number	Part Number	Index Number	Description Variation Number	Part Number
1	Screw, pozidrive T.H. 1/4-20X5/8" 6,7,8,9,15,17,20,22,23,24,25,28, 29,30,32,35,36,37,38,40,43,45, 48,308	25 086 21	6	Knob, throttle lever 6,7,8,9,15,17,20,22,23,24,25, 28,29,30,32,35,36,37,38,40,43, 45,48,307,308	52 341 01
2	Washer, spring 1/4" 6,7,8,9,15,17,20,22,23,24,25, 28,29,30,32,35,36,37,38,40,43, 45,48,307,308	52 468 11	7	Plate, throttle stop 6,7,8,9,15,17,20,22,23,24,25, 28,29,30,32,35,36,37,38,40,43, 45,48,307,308	52 146 07
3	Tab 6,7,8,9,11,20,22,24,25,28,29, 30,32,35,36,37,38,40,43,45,48, 307,308	52 448 02	8	Linkage, throttle 6,7,8,9,15,17,20,22,23,24,25, 28,29,30,32,35,36,37,38,40,43, 45,48,304,307,308	52 079 04
4	Washer, flat 6,7,8,9,12,15,17,20,22,23,24, 25,28,29,30,32,35,36,37,38,40, 43,45,48,49,50	52 468 10	9	Harness, wiring 6,7,8,9,11,15,16,18,20,23,24, 25,28,29,30,31,37,38,40,46, 307,308	52 176 03
5	Lever, throttle 6,7,8,9,15,17,20,22,23,24,25, 28,29,30,32,37,38,40,43,45,48, 49,50	52 090 08	9	Harness, wiring 17,19,22,32,45,310	52 176 04
5	Lever, throttle control 35,36	52 090 28	9	Harness, wiring 38	52 176 13
			9	Harness, wiring 35,36	52 176 11

M18 & M20

Instrument Panel
(Cont.)

Index Number	Description Variation Number	Part Number	Index Number	Description Variation Number	Part Number
9	Harness, wiring 41,43,44	52 176 15	20	Light, indicator (Use before Serial No. 2108000016) 400	25 352 07
9	Harness, wiring 47,78	52 176 17	21	Nut, speed 8,17,24,40,47,301,302,310	25 100 03
9	Harness, wiring 312	52 176 05	21	Nut, speed (Use before Serial No. 2108000016) 400	25 100 03
10	Clip, cable 6,7,8,9,11,15,17,18,19,20,22,23,24, 25,28,29,30,31,32,37,38,40,41,43, 44,45,46,307,308,310	234511	22	Connector 6,7,8,9,11,15,16,17,18,19,20,22,23, 24,25,28,29,30,31,32,35,36,37,38, 40,41,43,44,45,46,47,48,300,307, 308,310	48 155 01
10	Clamp, cable 49,50	235778	23	Panel, instrument 8,17,24,40	52 378 01
11	Cable, choke 6,7,8,9,11,15,16,17,18,22,23,24,25, 28,29,30,32,35,36,37,38,40,41,43, 44,45,48,307,308	52 225 01	23	Panel, instrument 6,7,9,11,12,15,16,18,20,22,25,28, 29,30,32,36,37,38,41,42,43,44,45, 48,49,50	52 178 01
12	Washer, plain 1/4" 3,6,7,8,9,11,15,16,17,18,19,20,22, 23,24,25,26,28,29,30,31,32,37,38, 40,41,43,44,45,46,307,308,310	X-25-95	23	Panel, instrument 400 Before Serial No. 2108000016 use: After Serial No. 2108000006 use:	52 378 01 52 178 01
13	Screw, hex. wash. hd. 1/4-20x3/4" 3,6,7,8,9,11,15,16,17,18,19,20,22, 23,24,25,26,28,29,30,31,32,37,38, 40,41,43,44,45,46,307,308,310	X-67-62	24	Switch assembly, key (Includes 25-27) 6,7,8,9,11,15,16,17,18,20,22,24,25, 28,29,30,31,32,36,37,38,40,41,43, 44,45,46,47,48,300,303,305,306, 307,308,309,310	25 099 04
14	Solenoid (Replaced by 25 435 01) 17,23	52 435 01	25	Key (Set of two) 6,7,8,9,11,15,16,17,18,20,22,24,25, 28,29,30,31,32,36,37,38,40,41,43, 44,45,47,48,300,303,305,306,307, 308,309,310	48 340 01
14	Solenoid 3,6,7,8,9,11,16,18,19,20,22,24,25, 26,28,29,30,31,32,37,38,40,41,43, 44,45,46,307,308,310	25 435 01	26	Washer 6,7,8,9,11,15,16,17,18,20,22,24,25, 28,29,30,31,32,36,37,38,40,41,43, 44,45,46,47,48,300,303,305,306, 307,308,309,310	48 468 02
14	Solenoid 15	45 435 07	27	Nut, key switch 6,7,8,9,11,15,16,17,18,20,22,24,25, 28,29,30,31,32,36,37,38,40,41,43, 44,45,46,47,48,300,303,305,306, 307,308,309,310	48 100 01
15	Washer, lock 1/4" (2) 3,6,7,8,9,11,15,16,17,18,19,20,22, 24,25,26,28,29,30,31,32,37,38,40, 41,43,44,45,46,307,308,310	X-20-1	28	Screw, hex. wash. hd. 10-24x3/8" 6,7,8,9,15,17,20,22,23,24,25,28,29, 30,32,37,38,40,42,43,45,48,308	X-67-97
16	Nut, hex. 1/4-20 (2) 3,6,7,8,9,11,15,16,17,18,19,20,22, 24,25,26,28,29,30,31,32,37,38,40, 41,43,44,45,46,307,308,310	X-81-1	29	Screw, hex. wash. hd. 1/4-20x7/16" 6,7,8,9,11,16,18,20,22,25,28,29,30, 32,37,38,40,41,42,43,44,45,46,308	X-67-83
17	Palnut 1/4-20 3,6,7,8,9,11,15,16,17,18,19,20,22, 23,24,25,26,28,29,30,31,32,37,38, 40,41,43,44,45,46,307,308,310	X-799-1	30	Washer, flat 1/4" 6,7,8,9,15,17,20,22,23,24,25,28,29, 30,32,35,36,37,38,40,43,45,48,308	52 468 10
18	Bracket, solenoid 3,6,7,8,9,11,15,16,17,18,19,20,22, 23,24,25,26,28,29,30,31,32,37,38, 40,41,43,44,45,46,307,308,310	52 126 06	31	Screw, hex. wash. hd. 10-24x3/8" 35,36	25 086 41
19	Bolt, R.H. sq. neck 1/4-20x9/16" 3,6,7,8,9,11,15,16,17,18,19,20,22, 23,24,25,26,28,29,30,31,32,37,38, 40,41,43,44,45,46,307,308,310	52 086 10			
20	Light, indicator 17,47,301,302,310	25 352 01			
20	Light, indicator 8,24,40	25 352 07			

**INSTRUMENT PANEL
(Cont'd)**

M18 & M20

Index Number	Description Variation Number	Part Number	Index Number	Description Variation Number	Part Number
32	Clip, lead 37,38	275303			
33	Tab 15,17,23	52 448 02			
34	Kit, ammeter (Includes 35,36) 19	48 755 18			
35	Bracket, ammeter 19	48 126 09			
36	Washer 19	X-19-1			
37	Connector, tab 17,301,310	25 155 03			
38	Connector, receptacle 17,301,310	25 155 04			
NOT ILLUSTRATED					
	Decal, throttle position (Use before Serial No. 2108000016) 400	52 113 18			
	Decal, throttle position 6,7,8,9,15,17,20,22,24, 28,29,30,32,36,37,38,40,43,45, 48,308	52 113 18			
	Decal, ignition 6,7,9,11,15,16,18,20,22, 28,29,30,32,36,37,38,41,43,44, 45,48,307,308,309	52 113 17			
	Decal, ignition (Use after Serial No. 2108000006) 400	52 113 17			
	Decal, throttle 25	52 113 37			
	Decal, ignition 25	52 113 38			
	Decal, ignition 8,17,24,40,47,310	52 113 29			
	Tie, cable 6,7,8,9,11,15,16,17,18,19,20, 22,23,24,25,28,29,30,31,32,37, 38,40,41,43,44,45,46,308,310	X-468-1			
				Lead, black, solenoid to starter (6" - 6 gauge - insulated grip barrel eyelet) 6,9,11,16,18,24,26,28, 30,31,32,37,43,44,45,46,310	52 518 03
				Lead, white, key to module (27" - 14 gauge - insulated push on tab, uninsulated push on tab) 6,7,8,11,17,18,23,24,25,28, 30,31,35,36,40,43,46,47,308,310	52 518 16
				Lead, white, key to module (27" - 14 gauge - insulated push on tab, uninsulated push on tab) (Use before Serial No. 2108000016) 400	52 518 16
				Lead, black, key to module (Use after Serial No. 2108000006) 400	52 518 18
				Lead, black, solenoid to starter (8-1/2" - 6 gauge - insulated grip barrel eyelet) 3,7,8,15,17,19,20,22,23,25, 29,38,40,41,308	52 518 02
				Lead, ground to kill (27" - 14 gauge - fully insulated push on tab, uninsulated push on tab; 21" - 18 gauge - fully insulated push on tab) 9,15,16,20,22,29,32,41,44,45,48	52 518 18
				Lead, red (3" - 18 gauge - uninsulated grip barrel eyelet, insulated push on tab) 15	25 518 20
				Lead, green (7" - 18 gauge - fully insulated push on tab, insulated grip barrel eyelet) 42	52 518 27
				Terminal 45	25 452 01
				Terminal 311	52 452 01
				Meter, hour 42	52 362 01
				Screw 42	52 086 11
				Washer, lock 1/4" 42	X-22-11

Group 22
PISTON & ROD

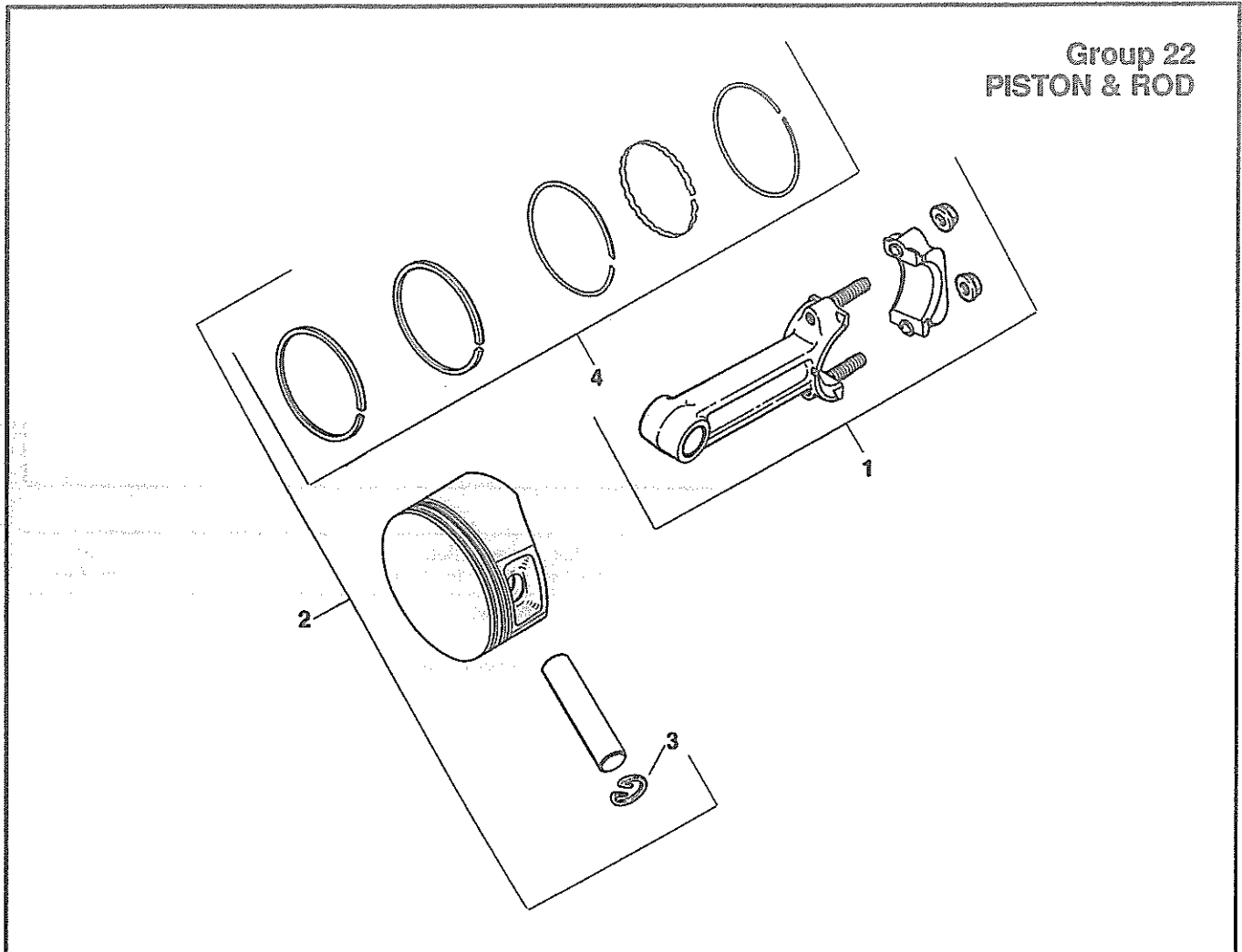

Index Number	Description Variation Number	Part Number	Index Number	Description Variation Number	Part Number
1	Connecting rod (Std.) (2) 14	52 067 67	2	Piston w/ring set (.020) 14	52 874 14
1	Connecting rod (.010) (2) 14	52 067 68	2	Piston w/ring set (.020) 15	52 874 19
1	Connecting rod (Std.) (2) 15	52 067 71	2	Piston w/ring set (.030) 14	52 874 15
1	Connecting rod (.010) (2) 15	52 067 72	2	Piston w/ring set (.030) 15	52 874 20
2	Piston w/ring set (Std.) 14	52 874 11	3	Retainer, piston pin (4) 14	230004
2	Piston w/ring set (Std.) 15	52 874 16	3	Retainer, piston pin (4) 15	52 141 01
2	Piston w/ring set (.003) 14	52 874 12	4	Ring set (Std. & .003) (2) 14,15	52 108 09
2	Piston w/ring set (.003) 15	52 874 17	4	Ring set (.010) (2) 14,15	52 108 10
2	Piston w/ring set (.010) 14	52 874 13	4	Ring set (.020) (2) 14,15	52 108 11
2	Piston w/ring set (.010) 15	52 874 18	4	Ring set (.030) (2) 14,15	52 108 12

**Group 25
OIL PUMP**

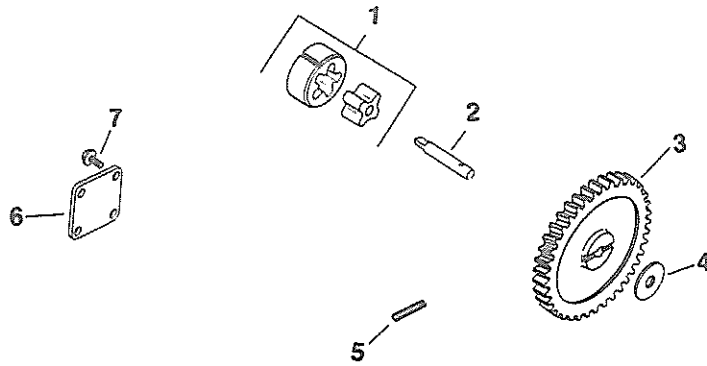

Index Number	Description Variation Number	Part Number	Index Number	Description Variation Number	Part Number
1	Rotor set 4	52 393 09	5	Pin, roll 4	X-280-25
2	Shaft, oil pump 4	52 144 05	6	Cover, oil pump 4	52 096 03
3	Gear, oil pump 4	52 043 05	7	Screw, hex. wash. hd. 10-32X7/16" (4) 4	X-67-64
4	Spacer, (A.R. Max. 2) 4	52 422 01			

M18 & M20

Group 29 Oil Filter

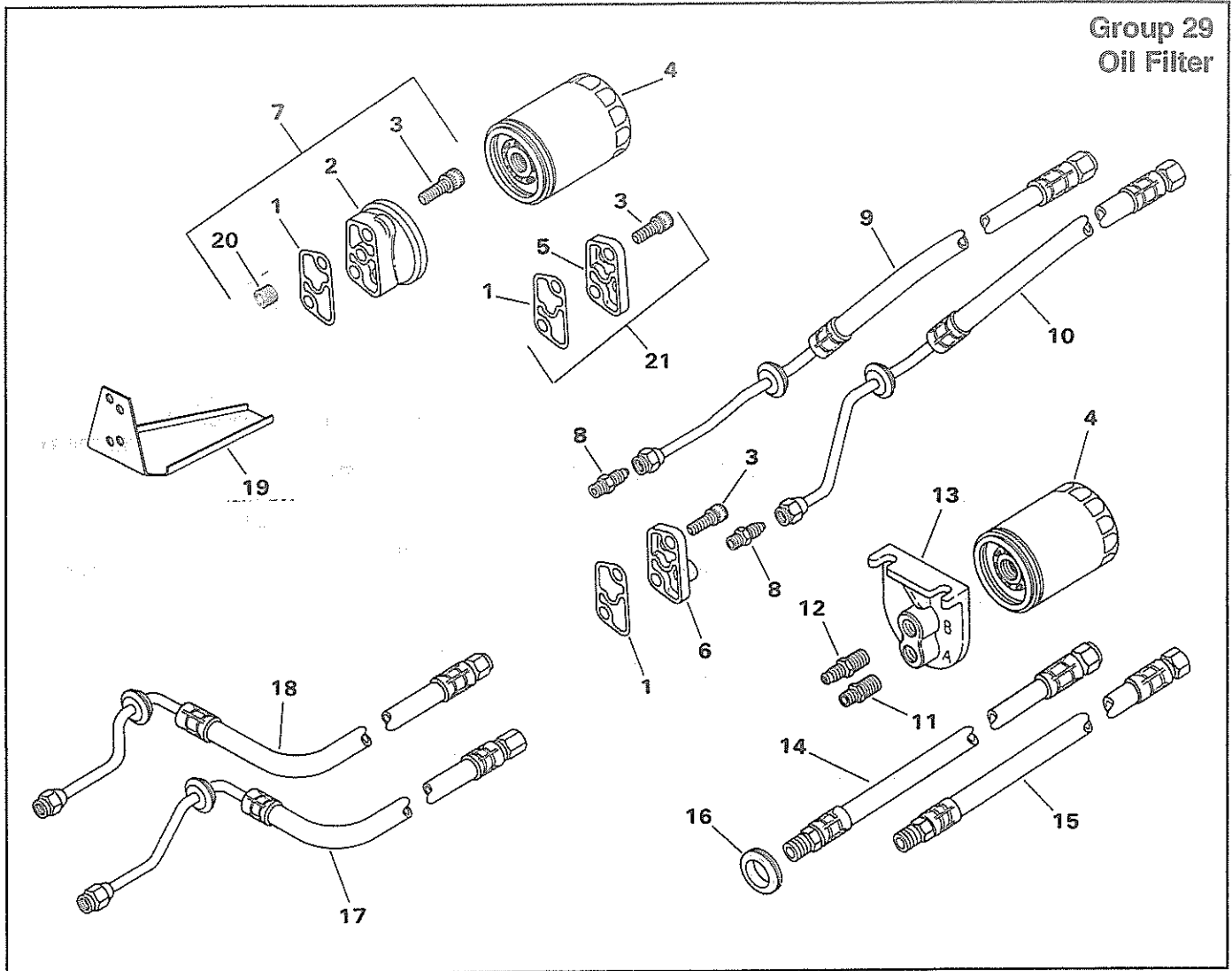

Index Number	Description Variation Number	Part Number	Index Number	Description Variation Number	Part Number
1	Gasket 2,3,4,6,7,8,9,11,12,13,14,16,18, 300,301	52 041 16	4	Oil filter 2,3,6,7,8,9,11,13,14,16,18,301	52 050 02
1	Gasket (Use after Serial No. 1926500006) 400	52 041 16	4	Oil filter 12	277233
2	Adapter 2,12,18	52 181 03	5	Cover, remote filter (Replaced by 52 755 67) (Use before Serial No. 1926500016) 3,6,16,400	25 096 03
2	Adapter (Replaced by 87 755 23) (Use after Serial No. 1926500006) 400	52 029 13	6	Cover, remote oil 7,8,9,11,16	52 096 33
2	Adapter (Replaced by 82 755 23) 13,14	25 029 03	6	Cover, remote oil (Use before Serial No. 1926500016) 400	52 096 33
3	Screw, hex. socket hd. cap 5/16-18x1-1/4" (2) 3,6,7,8,9,11,12,13,14,16,18,300, 301	X-55-15	7	Kit, oil filter adapter (Includes 1,3 [qty. 2],20) 13,14	82 755 23
3	Screw, hex. socket hd. cap 5/16-18x1-1/4" (4) 2	X-55-15	7	Kit, oil filter adapter (Includes 1,3 [qty. 2],20) (Use after Serial No. 1835400002) 301	82 755 23

**Oil Filter
(Cont.)**

M18 & M20

Index Number	Description Variation Number	Part Number	Index Number	Description Variation Number	Part Number
7	Kit, oil filter adapter (Includes 1,3 [qty. 2],20) (Use after Serial No. 1926500006) 400	82 755 23	14	Hose, oil (white tracer) (1/8-27 N.P.T.F. male coupling, 1/2-20 SAE 45° flare female coupling x 23" long) (Use before Serial No. 1926500016) 400	52 326 09
8	Connector, reducing (2) (1/2-20 SAE 45° Male Flare, 1/8-27 N.P.T.F. x 1-1/8" long) 6,7,8,9,11,16	52 155 07	15	Hose, oil (red tracer) (1/8-27 N.P.T.F. male coupling, 1/4-18 NPSM female coupling x 23" long) 3	52 326 11
9	Line, oil (white tracer) (1/2-20 SAE 45° flare female coupling, 1/2-10 female 45° flare nut x 19" long) 7	52 353 07	15	Hose, oil (red tracer) (1/8-27 N.P.T.F. male coupling, 1/4-18 NPSM female coupling x 23" long) (Use before Serial No. 1835400012) 301	52 326 11
10	Line, oil (red tracer) (1/4-18 NPSM female coupling, 1/2-20 female 45° flared nut x 20-1/2" long) 7	52 353 06	15	Hose, oil (red tracer) (1/8-27 N.P.T.F. male coupling, 1/4-18 NPSM female coupling x 23" long) (Use before Serial No. 1926500016) 400	52 326 11
11	Connector, reducing (1/2-20 SAE 45° male flare, 1/4-18 N.P.T.F. x 1-5/16" long) 3,6,7,8,9,11,16	52 155 03	16	Grommet (2) 3	52 313 03
11	Connector, reducing (1/2-20 SAE 45° male flare, 1/4-18 N.P.T.F. x 1-5/16" long) 301	52 155 03	16	Grommet (2) (Use before Serial No. 1835400012) 301	52 313 03
11	Connector, reducing (1/2-20 SAE 45° male flare, 1/4-18 N.P.T.F. x 1-5/16" long) (Use before Serial No. 1926500016) 400	52 155 03	16	Grommet (2) (Use before Serial No. 1926500016) 400	52 313 03
12	Nipple, hexagon (1/4-18 N.P.T.F. x 1" long) 3,6,7,8,9,11,16	52 136 02	17	Line, oil (red tracer) (1/2-20 SAE 45° flare female swivel coupling, 1/2-20 female 45° female nut x 13-3/4" long) (Discontinued not available at Kohler Co.) 8	52 353 10
12	Nipple, hexagon (1/4-18 N.P.T.F. x 1" long) 301	52 136 02	17	Line, oil (red tracer) (1/4-18 NPSM female swivel coupling, 1/2-20 female 45° flared nut x 20-1/2" long) 6,16	52 353 12
12	Nipple, hexagon (1/4-18 N.P.T.F. x 1" long) (Use before Serial No. 1926500016) 400	52 136 02	17	Line, oil (red tracer) (1/4-18 NPSM female swivel coupling, 1/4-20 female 45° flared nut x 12-3/4" long) 11	52 353 16
13	Adapter, remote oil filter 3,6,7,8,9,11,16	25 029 01	17	Line, oil (red tracer) (1/4-18 NPSM female swivel coupling, 1/4-20 female 45° flared nut x 13-3/4" long) 9	52 353 14
13	Adapter, remote oil filter (Use before Serial No. 1835400012) 301	25 029 01	17	Line, oil (red tracer) (1/4-18 NPSM female swivel coupling, 1/4-20 female 45° flared nut x 13-3/4" long) 9	52 353 14
13	Adapter, remote oil filter (Use before Serial No. 1926500016) 400	25 029 01	18	Line, oil (white tracer) (1/2-20 SAE 45° flare female swivel coupling, 1/2-20 female 45° female nut x 13-3/4" long) (Discontinued not available at Kohler Co.) 8	52 353 11
14	Hose, oil (white tracer) (1/8-27 N.P.T.F. male coupling, 1/2-20 SAE 45° flare female coupling x 23" long) 3	52 326 09	18	Line, oil (white tracer) (1/2-20 SAE 45° flare female swivel coupling, 1/2-20 female 45° female nut x 12-3/4" long) 16	52 353 21
14	Hose, oil (white tracer) (1/8-27 N.P.T.F. male coupling, 1/2-20 SAE 45° flare female coupling x 23" long) (Use before Serial No. 1835400012) 301	52 326 09			

M18 & M20

Oil Filter
(Cont.)

Index Number	Description Variation Number	Part Number	Index Number	Description Variation Number	Part Number
18	Line, oil (white tracer) (1/2-20 SAE 45° flare female swivel coupling, 1/2-20 female 45° female nut x 12-3/4" long)	52 353 17	20	Plug, allen hd. pipe 1/8" 13,14,400	X-75-23
18	Line, oil (white tracer) (1/2-20 SAE 45° flare female swivel coupling, 1/2-20 female 45° female nut x 13-3/4" long)	52 353 15	20	Plug, allen hd. pipe 1/8" (Use after Serial No. 1835400002) 301	X-75-23
18	Line, oil (white tracer) (1/2-20 SAE 45° flare female swivel coupling, 1/2-20 female 45° female nut x 19" long)	52 353 13	21	Kit, remote oil filter cover (Includes 1,3 [qty. 2]) 3,6,7,8,9,11,16	52 755 67
19	Trough, oil catch 18	52 459 01	21	Kit, non-filter cover (Includes 1,3 [qty. 2]) 4,300	52 755 66
			21	Kit, remote oil filter cover (Includes 1,3 [qty. 2]) (Use before Serial No. 1835400012) 301	52 755 67

M18 & M20

Group 31 High Temperature Cutout

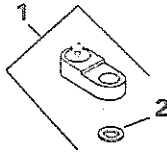

Index Number	Description Variation Number	Part Number	Index Number	Description Variation Number	Part Number
1	Kit, hi-temperature cutout (Includes 2) 1	47 703 01	2	Washer, hi-temperature cutout 1	47 468 07

Group 32 Low Oil Pressure Switch

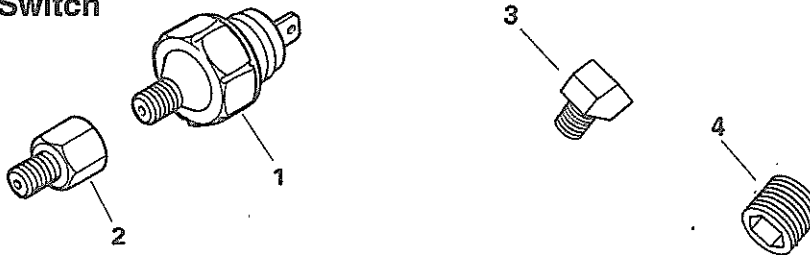

Index Number	Description Variation Number	Part Number	Index Number	Description Variation Number	Part Number
1	Switch, oil pressure 5,6,8,11,12,13,19,20,25,300,302, 303,305,306	52 099 06		Lead, green, pressure switch (16" - 18 gauge - insulated push on tab and uninsulated push on tab terminals) 6,301,306	52 518 08
1	Switch, pressure assembly 18,21,303	52 099 05		Lead, green (16" - 18 gauge - insulated push on tab) 20,25	52 518 25
1	Switch, low oil pressure 26	52 099 07		Clip,lead 19	275303
2	Reducer 12	52 158 05		Screw, hex. wash. hd. 10-32x7/16" 19	X-67-64
3	Elbow 21	25 054 01		Decal, oil sentry 5,6,8,12,19,20,25,26,300,304,306	25 113 05
4	Plug, hex. ctsk. 1/8" N.P.T.F. 15,19,303	X-75-23		Decal, oil sentry 302	25 113 14
Not Illustrated Lead, green, pressure switch (21" - 18 gauge - insulated push on tab and uninsulated push on tab terminals) 8,11,12,18,21,300,302					52 518 13

M18 & M20

Index Number	Description Variation Number	Part Number
	Gasket Set	52 755 94
	<i>Set includes:</i>	
	Oil Seal	X-583-5
	Gasket, carburetor	271030
	Gasket, air cleaner elbow	25 041 06
	Gasket, fuel pump	25 041 05
	Seal, breather	52 032 04
	Seal, valve stem (2)	52 032 13
	Seal, oil rear - 1-1/2" O.D.	52 032 08
	Seal, oil (2)	52 032 10
	Gasket, closure plate	52 041 15
	Gasket, intake (2)	52 041 09
	Gasket, exhaust (2)	52 041 10
	Gasket, oil filter cover	52 041 16
	Gasket, cylinder head (2)	52 041 20
	Gasket, valve cover (3)	52 055 01
	Gasket, air cleaner (2)	52 055 04
	Gasket, air cleaner	277093
	Gasket, exhaust (2)	52 041 14
	Gasket, fuel pump	25 041 09

THE NEW SHAPE OF KOHLER POWER

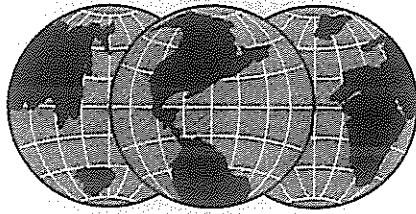

KOHLERengines

ENGINE DIVISION, KOHLER CO., KOHLER, WISCONSIN 53044

FOR SALES AND SERVICE INFORMATION
IN U.S. AND CANADA, CALL
1-800-544-2444

FORM NO.:	TP-2233-C
ISSUED:	3/86
REVISED:	10/91
MAILED:	2/92

LITHO IN U.S.A.