

# PARTS MANUAL

# MAGNUM

MODEL M12 12 HP

Engine Specs 471500-471583

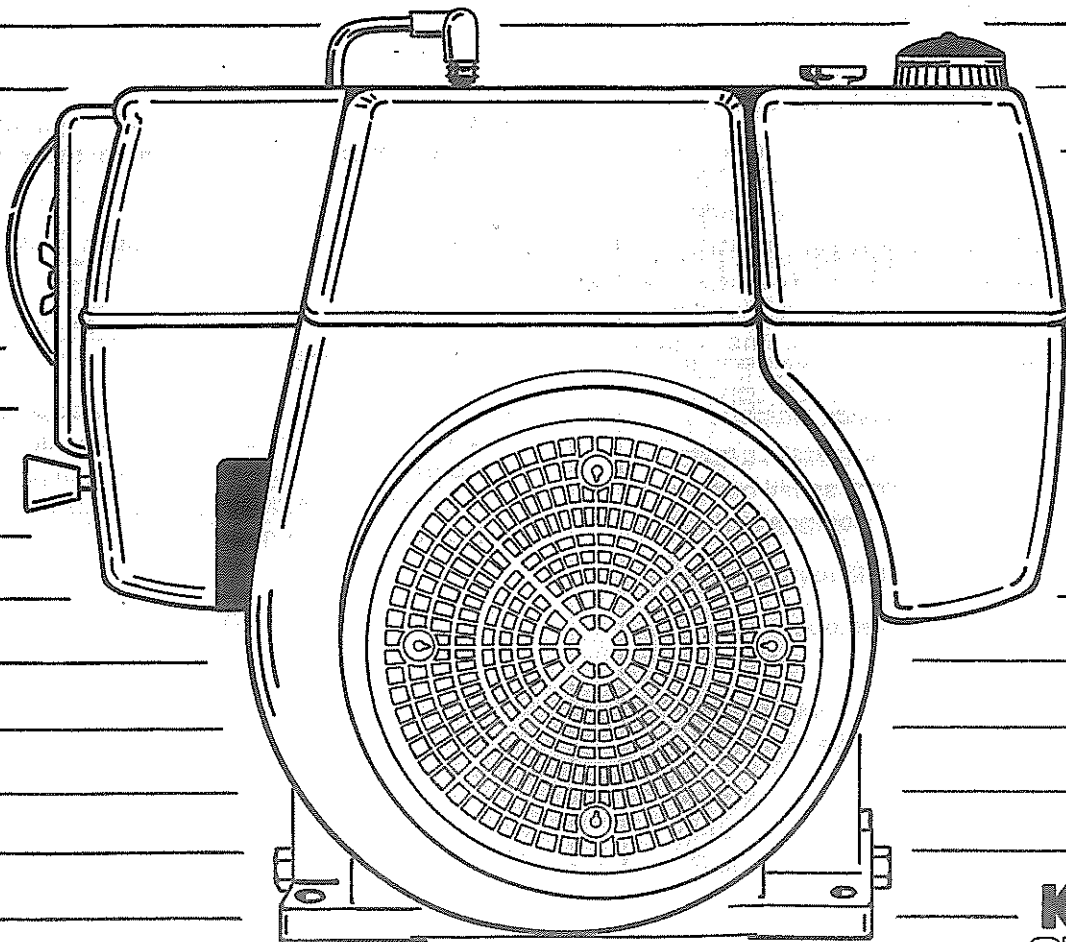

**KOHLER**  
engines

# HOW TO FIND YOUR PART NUMBER

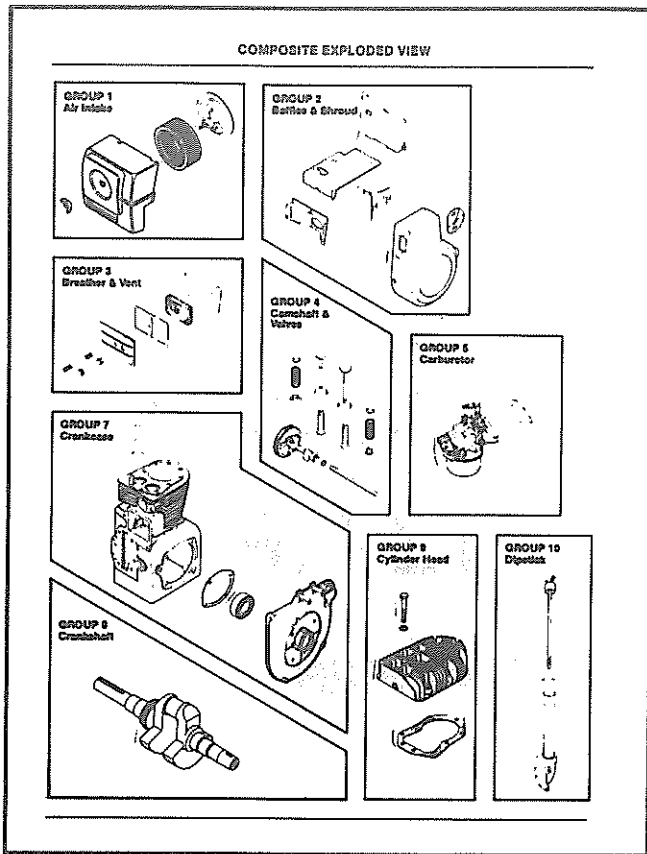

1. Turn the page of the parts manual to the "Composite Exploded View." Notice the boxed groupings identified by their function along with corresponding number. The group function and number applies to all engine models.

For Example:

Function (Group Description)	Group Number
Air Intake .....	1
Baffles & Shroud .....	2
Breather & Vent .....	3
Camshaft & Valves .....	4
Carburetor .....	5
Electric Starter .....	11
Ignition .....	18
etc.	

Remember the Group Number in which you located your part. (If the part you need is not illustrated, locate a major engine function related to your part and use that Group Number.)

**SPECIFICATION NUMBER INDEX**

Group Title & Number	1	2	3	4	5	7	8	9	10	11	12	13	14	15	16	17	18	19	20	22	23	24	25	26	
Air Intake	7	8	9	10	11	12	13	14	15	16	17	18	19	20	22	23	24	25	26						
Baffles & Shroud																									
Breather & Vent																									
Camshaft & Valves																									
Carburetor																									
Crankcase																									
Crankshaft																									
Cylinder Head																									
Dipstick																									
Electric Start																									
Exhaust																									
Flywheel																									
Fuel Pump																									
Fuel Tank																									
Gear Reduction																									
Governor																									
Ignition																									
Intake Manifold																									
Oil Pan																									
Piston & Rod																									
Rechargeable Start																									
Generator Set																									

Spec. No.      Variation Number

481500	576	573	512	26	78	213	105	60	568	44	717	582	566	576	737	544	558	1	511	27	
481501	576	572	512	26	78	213	105	60	568	44	715	582	566	576	737	544	556	1	511	27	
481502	576	571	512	26	78	213	105	60	568	576	44	716	582	566	575	736	543	556	1	511	27
481503	576	578	512	26	78	213	108	60	568	576	44	744	582	566	575	736	543	556	1	511	27
481516	576	572	512	26	78	213	105	60	568	44	765	582	566	576	738	544	558	1	511	27	
481520	576	571	512	26	78	213	105	60	568	576	44	718	582	566	588	736	553	558	1	511	27

Contact your Kohler engine parts supplier for any specifications not listed. For MiniBlocks, Short Blocks, and Replacement Engines refer to Selection Guide TP-2219. See Page 26 for Decal information.

2. Now turn to the pages titled "Specification Number Index." When scanning these pages, you'll notice:

- Page Numbers indexing where Group Parts are listed;
- Specification Numbers listed vertically down the first column;
- "Variation" Numbers in the Group Number columns. (These numbers specifically identify a particular group (combination) of parts used in a particular model(s)—and is used to locate the specific part number.)

# HOW TO FIND YOUR PART NUMBER

M10

Group 1  
AIR INTAKE

Index Number	Description	Part Number	Index Number	Description	Part Number
1	Wing nut 1/4-20	K-278-7	8	Element	45 033 02
2	Cover, air cleaner	47 006 06	7	Seal	331922
3	Nut, jam 1/4-20	41 109 04	6	Base, air cleaner	47 034 20
4	Cover, air cleaner element	33 002 04			
5	Freelance, element	45 033 01			

3. Look at the illustration and the listing of the parts making up that group.

A. All parts in the illustration are identified (or indexed) with a number or letter. Use that identifier to locate that part description in the listing.

B. The "Variation" Number that you located in the Spec Index page is the number you should locate in the parts listing. It is a critical reference to correct part number identification.

C. Part Numbers are listed in the column to the right of Variation Numbers.

M10

There are several methods of repowering M10 engines to consider—with the choice depending on your shop facilities, repair costs, and allowable downtime of the engine.

- Engine Replacement:** When decision is to replace, use a Kohler Replacement Engine—No modifications required.
- Short Block Replacement:** When engine including the crankshaft is extensively damaged or worn internally. Refer to page 3 for short block components.
- Miniblock Replacement:** When bore, piston, and connecting rod are damaged but crankshaft and all other parts are in good condition. Refer to page 3 for miniblock components.
- Complete Overhaul:** Rebore cylinders and grind crankshaft, using appropriate oversize and/or undersize replacement parts.

This Selection Guide provides an easy reference for determining the part number of the Replacement Engine, Short Block, or Miniblock required for the repower method selected. It also lists the part number of the crankshaft installed in the original engine.

Locate the engine specification number in the index below. Select the part number of the repair method listed in the adjacent columns.

ENGINE SPECIFICATIONS					
Engine Spec. No.	Sugg. Service Engine No.	Original Engine No.	Replac. Short Block	Replac. Miniblock	Replac. Engine
481500	401500	47 142 02	—	—	47 782 32
481501	461501	47 142 02	—	—	47 782 32
481502	401502	47 142 02	—	—	47 782 32
481503	401503	47 142 02	—	—	47 782 32
481518	—	47 142 02	—	—	47 782 32
481820	—	47 142 02	—	—	47 782 32

Base Engine

## Special Features

Near the end of the Parts Manual Binder is a separate section devoted to Service Engines, Short Blocks, and Miniblocks. "Selection Guides" for each model engine give several different methods of repairing Kohler engines . . . with the choice dependent on shop facilities, costs, and allowable downtime of the engine and/or the equipment.

Selection Guides are easy references for determining part numbers of Replacement Engines, Short Blocks, or Miniblocks for the repair method selected. They also list part numbers of crankshafts installed in original engines.

Here is what you'll find:

A. Engine model is identified on each page for easy reference;

B. Bold column heads identify the various repower options for every engine spec;

C. All crankshaft changes required for Service Engines or Replacement Engines are flagged with "Yes;"

D. Service Engines, Replacement Engines, Short Blocks, and Miniblocks.

# COMPOSITE EXPLODED VIEW

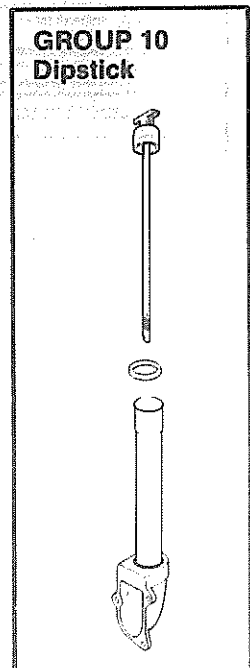
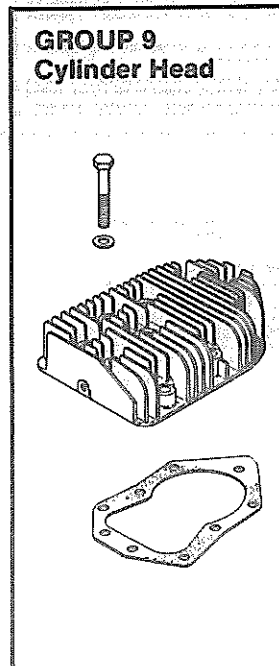
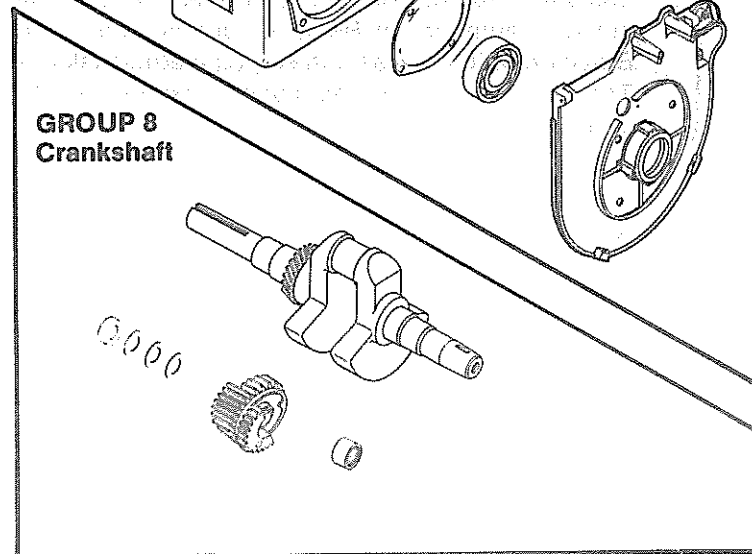
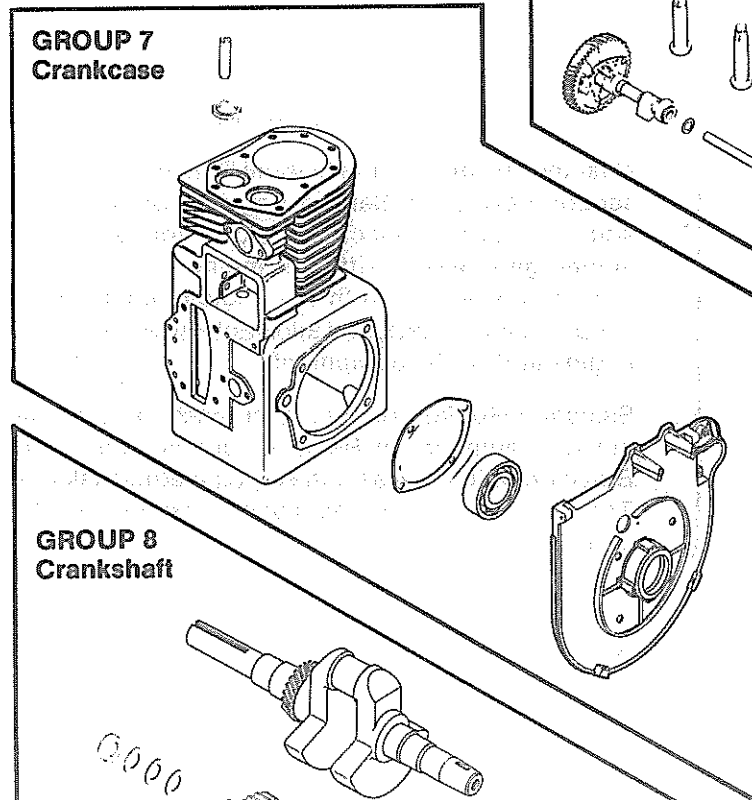
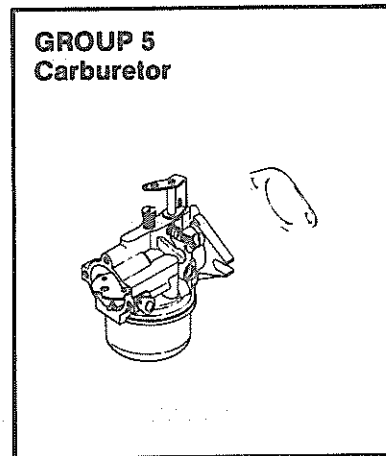
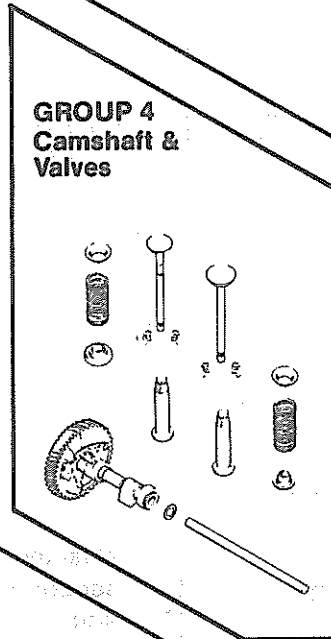
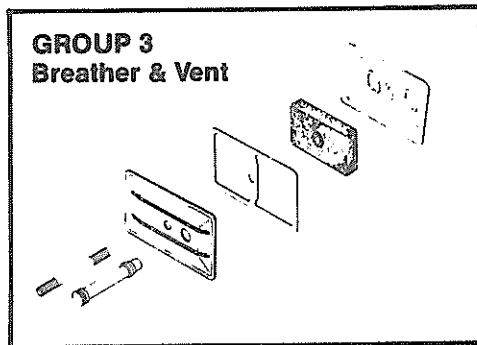
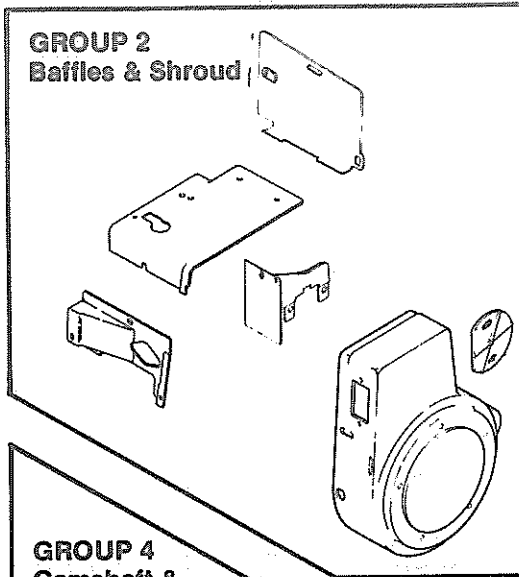
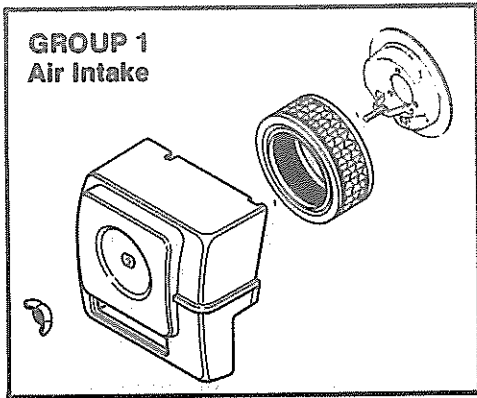

# COMPOSITE EXPLODED VIEW

**GROUP 11**  
Electric Start

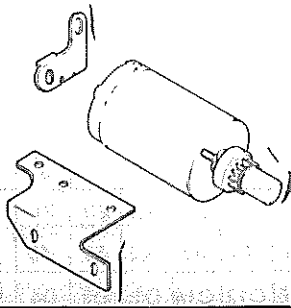

**GROUP 12**  
Exhaust

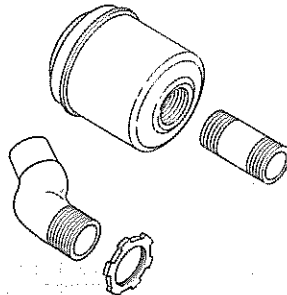

**GROUP 13**  
Flywheel

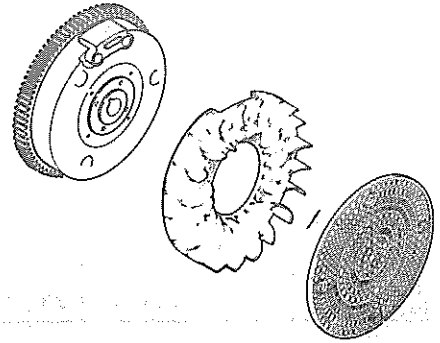

**GROUP 14**  
Fuel Pump

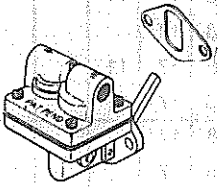

**GROUP 15**  
Fuel Tank

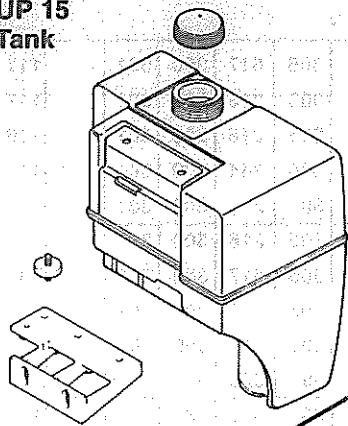

**GROUP 17**  
Governor

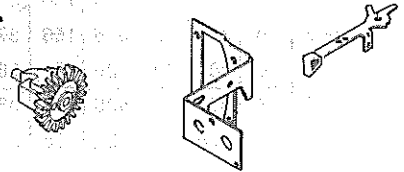

**GROUP 16**  
Gear Reduction

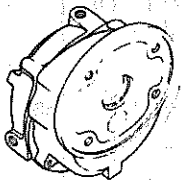

**GROUP 18**  
Ignition

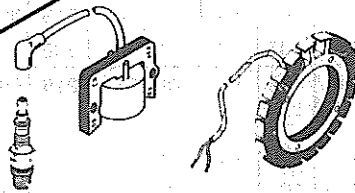

**GROUP 19**  
Instrument Panel

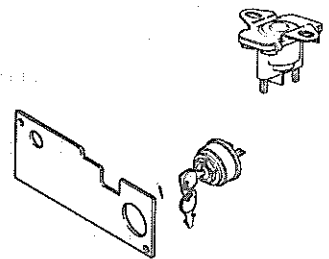

**GROUP 21**  
Oil Pan

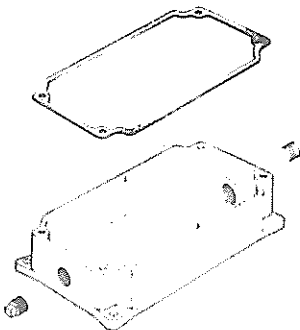

**GROUP 22**  
Piston & Rod

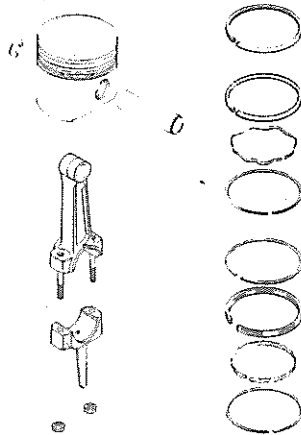

**GROUP 23**  
Retractable Starter

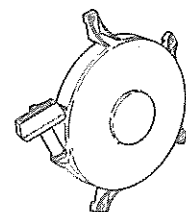

## SPECIFICATION NUMBER INDEX

Group Title & Number	AIR INTAKE	BAFFLES & SHROUD	BREATHER & VENT	CAMSHAFT & VALVES	CARBURETOR	CRANKCASE	CRANKSHAFT	CYLINDER HEAD	DIPSTICK	ELECTRIC START	EXHAUST	FLYWHEEL	FUEL PUMP	FUEL TANK	GEAR REDUCTION	GOVERNOR	IGNITION	INSTRUMENT PANEL	OIL PAN	PISTON & ROD	RETRACTABLE STARTER	REMOTE THROTTLE	OIL PRESS. CUTOFF
	1	2	3	4	5	7	8	9	10	11	12	13	14	15	16	17	18	19	21	22	23	24	32
Page No.	8	10	12	13	14	17	19	20	21	22	24	25	27	29	31	32	38	40	42	43	44	46	46
Grid No.	A8	A10	A12	A13	A14	B3	B5	B6	B7	B8	B10	B11	B13	C1	C3	C4	C10	C12	C14	D1	D2	D4	D4

Spec. No. \_\_\_\_\_ Variation Number \_\_\_\_\_

471500	98	289	12	826	156	375	148	105	68		305	617	300	301		117	237	44	58	17			
471501	98	287	12	826	156	375	148	105	68		305	215	300	301		117	237	44	58	17	11		
471502	98	500	12	826	156	375	148	105	68	76	305	216	300	301		116	236	43	58	17			
471503	98	302	12	826	156	375	148	105	68	76	305	244	300	301		116	236	43	58	17	11		
471504	98	287	12	826	156	381	157	105	68		305	215	300	301		79	237	49	58	17	11		
471505	98	302	12	826	156	381	157	105	68	76	305	216	300	301		79	236	53	58	17			
471506	98	289	12	826	156	381	158	105	68		305	617	300	301		79	237	49	58	17			
471507	98	287	12	826	156	381	158	105	68		305	215	300	301		79	237	49	58	17	11		
471508	98	287	12	826	156	375	159	105	68		305	215	300	301	2	117	237	44	58	17	11		
471512	99	304	13	826	153	383	161	105	69	79	39	223	301			112	300		36	17			
471514	99	330	13	826	153	406	174	105	69	78	39	618	92			114	246		54	17			
471515	98	297	12	826	153	394	148	105	68	77		216	300	81		81	255		854	17			
471516	86	314	12	826	144	394	148	105	68		11	215	300	81		97	269		854	17	8		
471519	98	306	12	826	300	401	148	105	68	76	305	219	82	83		116	237	54	854	17			
471525	101	305	12	826	153	397	167	105	28			290	95			96	280		1	17	11		
471527	102	298	12	826	153	394	148	105	69	78	39	216	59			104	264		624	17		826	3
471528	100	300	13	826	144	394	148	105	68	78	45	224	70			107	261		854	17			
471529	101	313	12	826	153	397	167	105	28	79		216	95			96	259		1	17			
471530	300	315	9	826	157	402	170	105	28	78		216	91			95	259		1	17			
471532	98	286	12	826	300	375	159	105	68	76	305	216	82	79	2	116	236	43	58	17			
471534	69	322	1	828	1	404	168	105	48	83		285	51			68	272		59	17	11		4
471535	69	323	1	828	1	404	168	105	48			286	51			68	273		59	17	11		4
471536	94	297	12	826	144	394	169	105	68	76	306	216	82	67		104	259		1	17			
471537	301	327	12	37	*	405	148	105	68	84		216	4			123	286	300	58	17			
471538	98	298	12	826	144	394	148	105	65	78		216	59			100	255		23	17			
471541	98	286	12	826	300	375	162	105	68	300	300	216	82	66		118	267	51	58	17			
471542	98	287	12	826	300	412	148	105	68		53	284	300	301		117	237	44	58	17	12		
471543	98	331	12	826	300	375	148	105	68		50	215	59			117	237	44	58	17	8		
471545	98	501	12	826	153	405	148	105	68	76	305	216	300	80		120	282	301	58	17			
471546	102	298	12	826	153	394	148	105	69	78	39	216	59			104	264		624	17		826	3
471547	107	290	12	37	164	375	148	105	68	80		216	4			127	236	43	58	17			
471548	98	290	12	826	156	375	148	105	68	80	305	216	303			116	236	43	58	17			
471549	104	297	13	826	144	405	148	105	68	300	301	216	300	300		140	255	302	58	17			
471550	98	287	12	826	156	378	31	105	68		302	215	82	84		117	237		63	17	11		
471553	98	287	12	826	300	411	173	105	68		303	284	300	300		79	237	49	59	17	12		2

\*Carburetor removed after test.

# SPECIFICATION NUMBER INDEX

Group Title # Number	AIR INTAKE	BAFFLES & SHROUD	BREATHER & VENT	CAMSHAFT & VALVES	CARBURETOR	CRANKCASE	CRANKSHAFT	CYLINDER HEAD	DIPSTICK	ELECTRIC START	EXHAUST	FLYWHEEL	FUEL PUMP	FUEL TANK	GEAR REDUCTION	GOVERNOR	IGNITION	INSTRUMENT PANEL	OIL PAN	PISTON & ROD	RETRACTABLE STARTER	REMOTE THROTTLE	OIL PRESS. CUTOFF
	1	2	3	4	5	7	8	9	10	11	12	13	14	15	16	17	18	19	21	22	23	24	32
Page No.	8	10	12	13	14	17	19	20	21	22	24	25	27	29	31	32	38	40	42	43	44	46	46
Grid No.	A8	A10	A12	A13	A14	B3	B5	B6	B7	B8	B10	B11	B13	C1	C3	C4	C10	C12	C14	D1	D2	D4	D4

Spec.  
No.

Variation Number

471554	98	287	12	826	300	381	157	105	68		304	215	300	300		79	237	49	59	17	11		2
471555	98	286	12	826	156	381	157	105	68	76	304	283	300	300		79	236	53	59	17			2
471556	98	286	12	826	156	381	172	105	68	76	305	216	300	84		116	236	63	59	17			5
471557	98	302	12	826	156	375	148	105	68	76	50	244	300	300		116	271	68	59	17	11		5
471558	69	322	1	828	163	404	168	105	48			285	300			68	272		59	17	11		9
471559	69	323	1	828	163	404	168	105	48	83		286	302			68	273		59	17	11		9
471560	98	500	12	826	156	375	159	105	68	76	305	216	300	84	2	116	236	43	58	17			
471561	300	315	9	826	157	402	170	105	28	78		216	91			95	259		1	17			
471562	98	331	12	826	300	378	148	105	68		39	215	59			148	237	71	58	17	8		
471563	101	287	12	826	156	417	10	105	68		1	215	300	84		117	237	44	59	17	11		5
471564	101	286	12	826	156	417	10	105	68	76	1	216	300	84		116	236	43	59	17			5
471566	98	302	12	826	156	381	148	105	68	76		244	93	84		116	236	43	58	17	11		
471567	69	322	1	828	163	404	168	105	48			285	302			68	272		59	17	11		9
471568	69	323	1	828	163	404	168	105	48	83		286	302			68	273		59	17	11		9
471569	87	341	12	39	144	405	148	105	68	76	11	216	93	80		119	237	60	58	17			
471570	98	287	12	826	156	418	174	105	68		50	284	93	84		117	237	44	67	17	12		
471571	98	354	12	826	156	419	166	105	68	76	308	216	93	84		500	236	303	58	17			
471572	98	287	12	826	156	411	173	105	68		305	215	93	84		79	237	49	59	17	11		2
471573	302	344	12	828	153	420	168	105	69		39	297	106			149	272		59	17	13		9
471574	110	346	12	828	153	420	168	105	69	83	39	298	106			153	273		59	17	13		9
471575	110	345	12	828	153	420	168	105	69		39	297	106			98	272		59	17	13		9
471576	110	342	12	826	153	423	166	105	68	76	307	301	93	83		98	236	90	58	17			656
471577	98	289	12	826	156	375	162	105	68		305	295	93	84		501	237	304	58	17			
471578	98	351	12	826	156	375	176	105	68	76	305	216	93	84		152	236	92	59	17			5
471579	98	350	12	826	156	375	176	105	68		305	299	93	84		151	237	93	59	17	13		5
471580	101	317	12	826	153	424	177	105	68	78	309	224	107			100	294		57	17			
471581	98	355	12	826	153	394	148	105	68	76	50	294	93	84		100	282	300	58	17			
471582	98	351	12	826	156	375	148	105	68	76	305	216	93	84		152	236	74	58	17			
471583	98	289	12	826	156	375	158	105	68		305	295	93	84		160	237	81	58	17			

# M12

## Group 1 AIR INTAKE

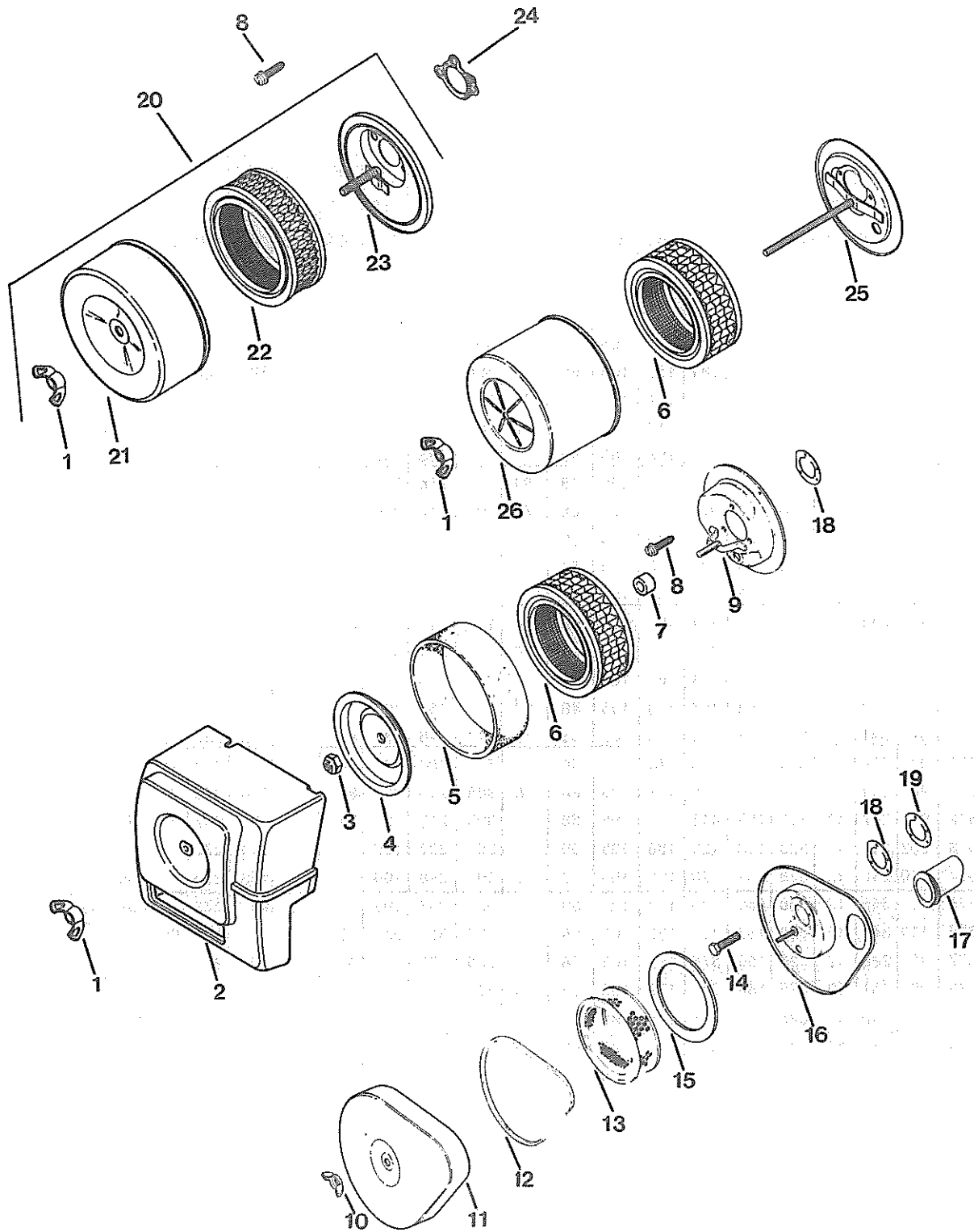



Index Number	Description Variation Number	Part Number	Index Number	Description Variation Number	Part Number
1	Wing nut 1/4-20 69,86,87,98,101,102,107,110, 300,301,302	X-276-7	13	Element 99,104	47 083 01
2	Cover, air cleaner (Replaced by 47 096 13) 86,87	47 096 09	13	Element 100	47 083 03
2	Cover, air cleaner (Replaced by 47 096 12) 98,107,301	47 096 08	14	Screw, hex. hd. 10-32 x 15/16" (3) 99,100,104	47 086 19
2	Cover, air cleaner (w/hole for fuel line) 102	47 096 10	15	Gasket, base 94	47 041 11
2	Cover, air cleaner 110,302	47 096 15	16	Base, air cleaner 99,104	47 094 11
3	Nut, jam 1/4-20 86,87,94,98,101,102,107,110, 300,301,302	41 100 04	16	Base, air cleaner 100	47 094 08
4	Cover, air cleaner element 89,87,94,98,101,102,107,110, 300,301,302	52 082 04	17	Tube, air 99,100	47 134 02
5	Precleaner, element 86,87,94,98,101,102,107,110, 300,301,302	45 083 01	18	Gasket, air horn 86,87,94,98,99,100,101,102, 104,110,301,302	45 041 07
6	Element 86,87,94,98,101,102,107,110, 300,301,302	45 083 02	18	Gasket, air horn (2) 107	45 041 07
7	Seal 86,87,94,98,101,102,107,110, 300,301,302	231032	19	Spacer 99,100,104	47 112 20
8	Screw, hex. wash. hd. 10-32 x 11/32" (3) 86,87,94,98,101,102,107,110, 301,302	X-67-65	20	Cleaner, air assembly (Includes 1,21,22,23 and decal 25 113 07) 69	A-235100
8	Screw, fill. hd. sems 10-32 x 3/8" (3) 300	X-167-2	21	Cover, air cleaner 94	47 082 02
9	Base, air cleaner 86,87,94,102,107,110,301,302	47 094 20	21	Cover, air cleaner 69	235102
9	Base, air cleaner 98,101,102	47 094 20	22	Element, air cleaner 69	235116
10	Wing nut 1/4-20 94,99,100,104	X-276-7	23	Base, air cleaner 69	235101
11	Cover, air cleaner 99,104	47 082 01	24	Gasket, air horn 69,300	275341
11	Cover, air cleaner 100	47 082 03	25	Base, air cleaner 300	45 094 01
12	Seal, cover 99,100,104	47 032 03	26	Cover, air cleaner 300,101	45 082 01
				NOT ILLUSTRATED	
				Decal, air cleaner 86,87,98,102,107,301	41 113 02
				Decal, air cleaner 69,94,99,100,101,104,300	25 113 07
				Decal, air cleaner 302	15 113 03

**Group 2  
BAFFLES & SHROUD**

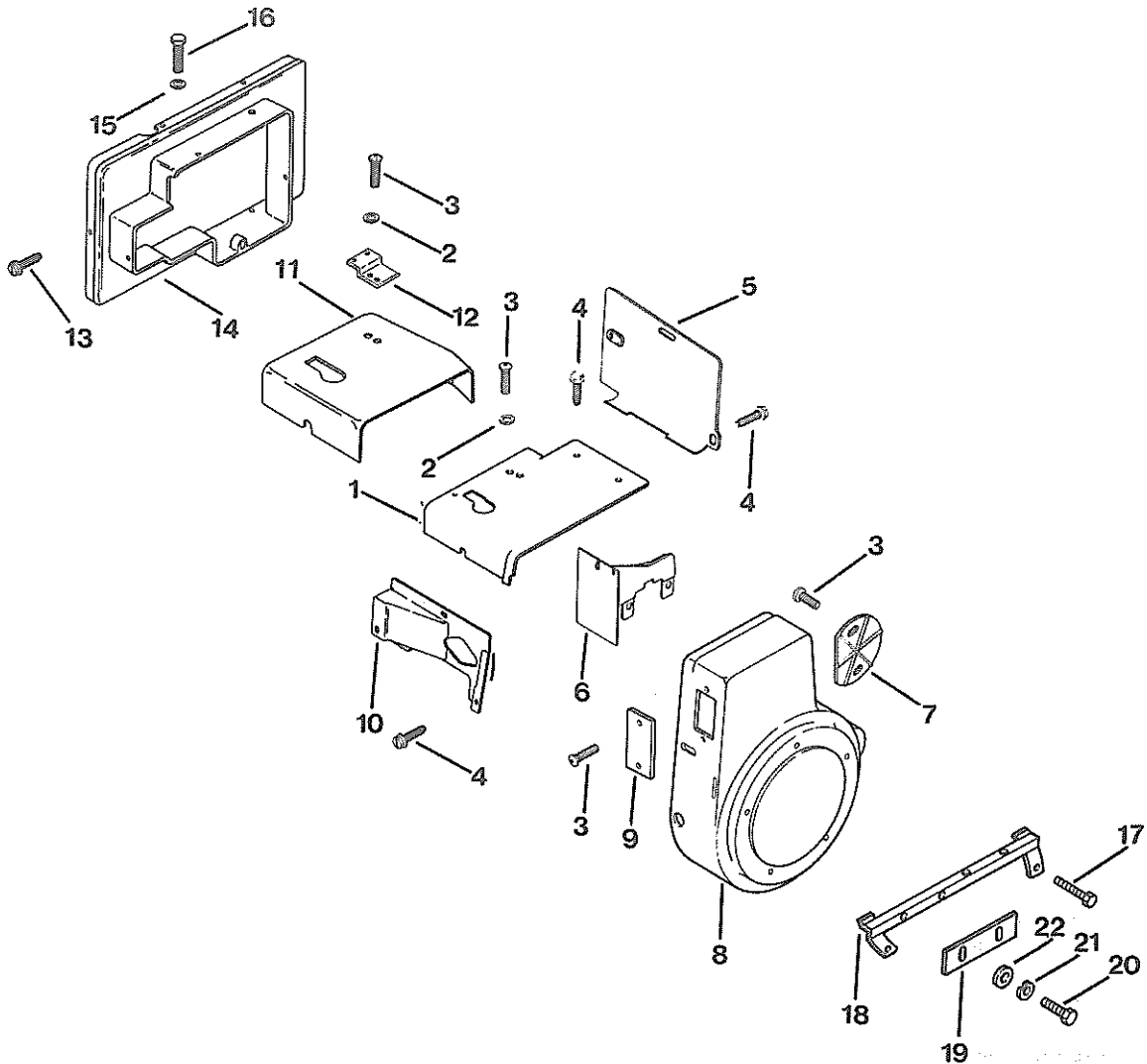

Index Number	Description Variation Number	Part Number	Index Number	Description Variation Number	Part Number
1	Baffle, head 286,287,289,297,302,306,314,341, 342,350,351,354,355,500,501	45 063 07	3	Screw, self top 1/4-20 x 7/16" (2) 345,346,350	X-67-83
2	Washer, plain 1/4" 286,287,289,290,297,298,300,302, 304,305,306,313,314,315,317,322, 323,327,330,331,341,342,344,345, 346,350,351,354,355,500,501	X-25-53	4	Screw, hex. wash. hd. 1/4-20 x 5/8" (6) 286,287,289,290,297,298,302,305 306,313,314,315,317,322,323,327, 331,341,342,344,345,346,350,351, 354,355,500,501	52 086 11
3	Screw, pozidriv T.H. 1/4-20 x 5/8" 286,290,297,298,300,302,304,306 313,315,317,327,330,342,346,351, 354,355,500,501	47 086 08	4	Screw, hex. wash. hd. 1/4-20 x 5/8" (8) 300,304,330	52 086 11
3	Screw, pozidriv T.H. 1/4-20 x 5/8" (5) 287,289,305,314,322,331	47 086 08	5	Baffle, cylinder (w/o bracket) 286,287,289,290,297,298,300,302, 304,305,306,313,314,315,317,322, 323,327,330,331,341,342,350,351, 354,355,500	47 063 10
3	Screw, pozidriv T.H. 1/4-20 x 5/8" (2) 306,344	47 086 08	5	Baffle, cylinder (w/bracket) 322,323,344,345,346,501	47 063 13
3	Screw, pozidriv T.H. 1/4-20 x 5/8" (3) 323,341,345,350	47 086 08			

Index Number	Description Variation Number	Part Number	Index Number	Description Variation Number	Part Number
6	Baffle, inner 286,287,289,290,297,298,300,302, 304,305,306,313,314,315,317,322, 323,327,330,331,341,342,344,345, 346,350,351,354,355,500,501	47 063 07	11	Baffle, head 290,298,300,304,313,315,317,322, 323,327,330,331,344,346,348	45 063 08
7	Cover, starter 287,289,305,314,322,331,344,345, 350	41 096 25	12	Bracket, air duct 300,304,330	47 126 23
8	Housing, blower (w/o retractable starter holes - front) 286,289,290,306,327,500	47 027 37	13	Screw, hex. wash. hd. 10-32 x 7/16" (3) 300,304,330	X-67-64
8	Housing, blower (w/retractable starter holes - front) 287,302,322,323,331,500	47 027 38	14	Kit, air duct (Includes Item 4, qty. 1, Item 13, qty. 3) 300,304	47 755 33
8	Housing, blower (Remote throttle & choke control holes) 297,298,317,501	47 027 42	14	Kit, air duct (Includes Item 4, qty. 2, Item 13, qty. 1) 330	47 755 32
8	Housing, blower 300	47 027 41	15	Washer, plain 1/4" 300,304,322,323,330,344,345,346	X-25-20
8	Housing, blower (Air cleaner tube hole-left side) 304,330	47 027 40	16	Screw, H.C. sems 5/16-18 x 1-1/4" 300,304,330	X-154-4
8	Housing, blower (Extra weld nut at top of housing) 305,313,314,315,341,342,355	47 027 44	16	Screw, H.C. sems 5/16-18 x 1/2" 322,323,344,345,346	X-154-6
8	Housing, blower 344,345,346	47 027 49	17	Screw, flange lock 10-24 x 1/4" (2) 313,315	41 086 06
8	Housing, blower 350,351,354	47 027 47	18	Deflector, grass 313,315	47 265 01
9	Cover, rectifier - regulator 287,289,305,306,314,331,341,344, 345,346,350	41 096 23	19	Blade, adjustable (2) 313,315	47 040 02
9	Cover, rectifier - regulator 322,323	25 096 01	20	Screw, tapping 8-32 x 3/8" (4) 313,315	X-67-59
10	Baffle, side air 286,287,289,290,297,298,300,302, 304,306,314,330,331,341,342,350, 351,355,500,501	47 063 06	21	Lockwasher #8 (4) 313,315	X-22-7
10	Baffle, side air 305,313,315,317	47 063 11	22	Washer, plain 3/16" (4) 313,315	25 468 02
10	Baffle, side air 322,323,327,344,345,346,354	47 063 12	NOT ILLUSTRATED		
				Decal, H.P. (black) 327,501	47 113 21
				Decal, warning (white) 313,315	52 113 11
				Decal, H.P. (white) 286,287,289,290,297,298,300,302, 304,305,306,313,314,315,317,322, 323,330,331,341,342,344,345,346, 350,351,354,355,500	47 113 20

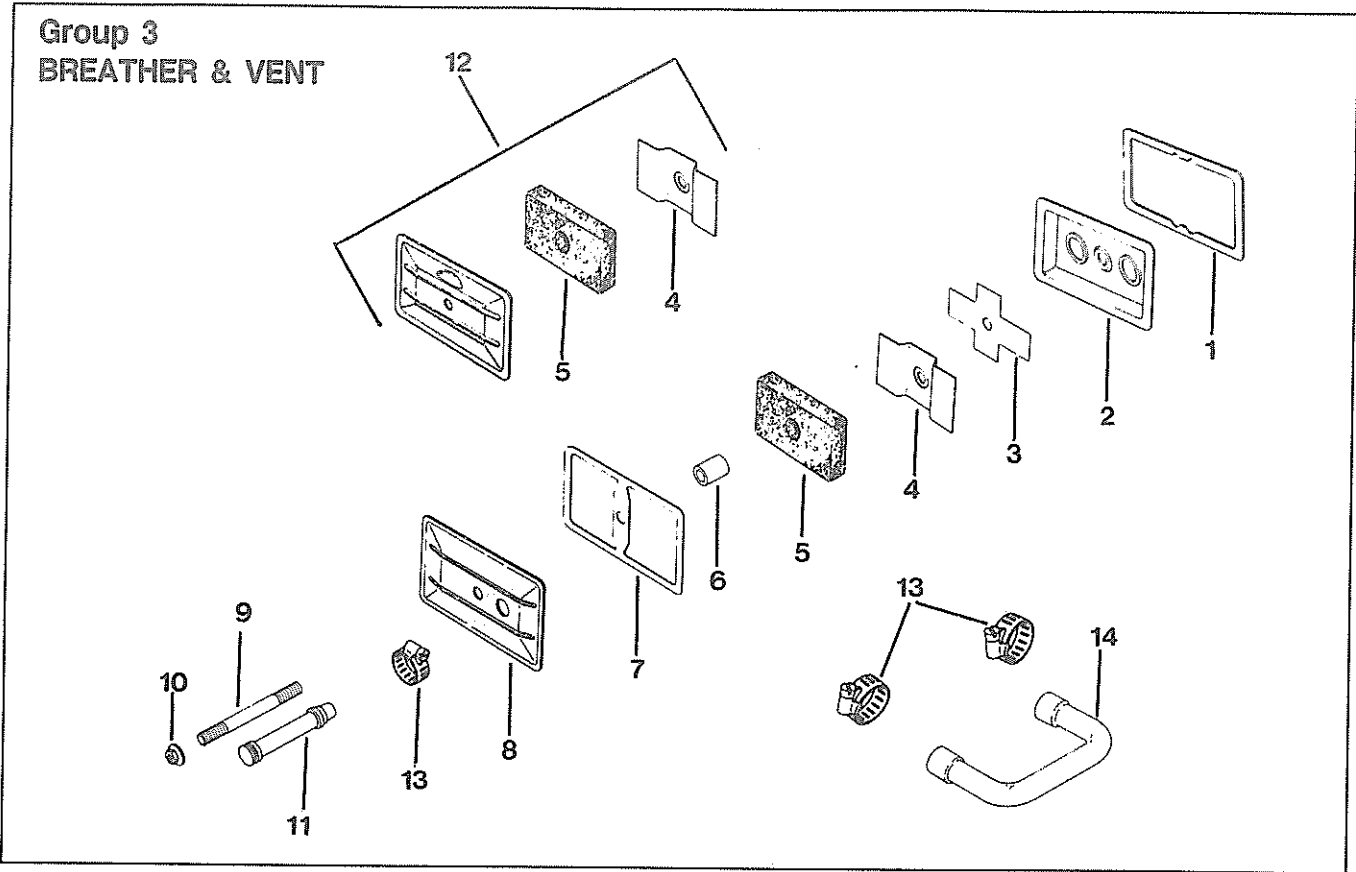

Index Number	Description Variation Number	Part Number	Index Number	Description Variation Number	Part Number
1	Gasket, breather plate 1,9,12,13	235048	8	Cover, valve 9	275839
2	Plate, breather 1,9,12,13	235631	8	Cover, valve 12,13	47 096 01
3	Reed, breather 1,9,12,13	235047	9	Stud 1/4-20 x 3-1/4"	275220
4	Baffle, breather 1,9	235117	10	Palnut 1/4-20"	X-799-1
4	Baffle, breather 12,13	270146	11	Hose, breather 3-11/32" lg.	47 326 03
5	Filter, breather 1,9	235118	11	Hose, breather 3-29/32" lg.	47 326 04
5	Filter, breather 12,13	47 050 01	12	Cover, valve assembly (Includes 4,5)	A-235418-S
6	Seal, breather 1,9,12,13	231032	13	Clamp, hose 1/2" wide (2) 9,13	X-426-3
7	Gasket, valve cover 1,9,12,13	275144	14	Hose, breather 9	47 326 02

# M12

## Group 4 CAMSHAFT & VALVES

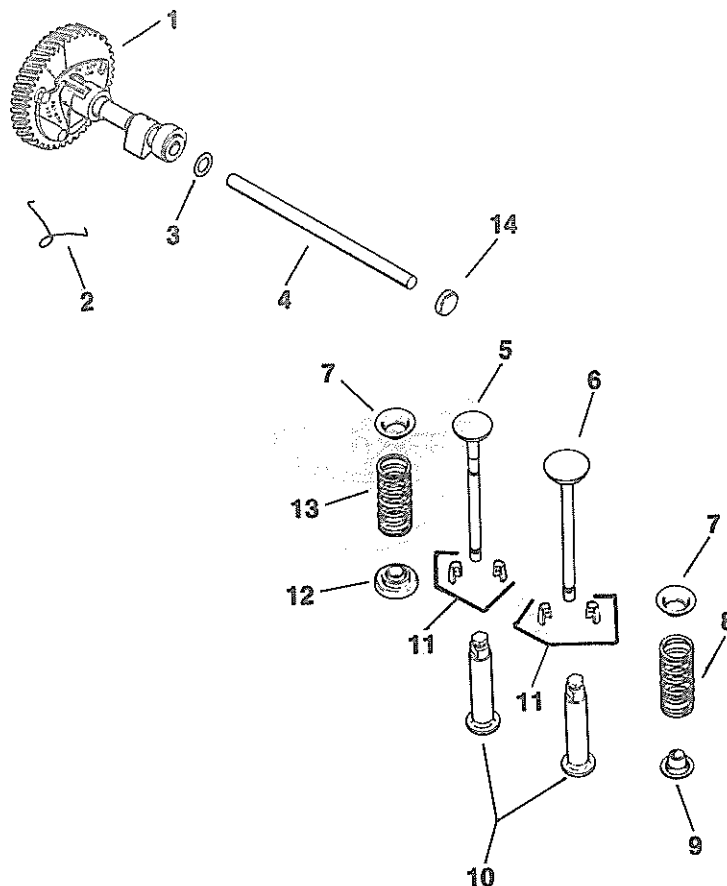

Index Number	Description Variation Number	Part Number	Index Number	Description Variation Number	Part Number
1	Camshaft assembly (Includes 2) 37,826,828	47 010 11	7	Retainer, upper spring (2) 37,39,826,828	235011
1	Camshaft assembly 39	47 010 07	8	Spring, intake valve 37,39,826	235010
2	Spring, actuating 37,826,828	47 089 01	9	Retainer, spring 37,39,826	230011
3	Spacer .005 (A.R.) 37,39,826,828	275066	10	Tappet (2) 37,39,826,828	D-235327
3	Spacer .010 (A.R.) 37,39,826,828	275067	11	Kit, retainer (2) 37,39,826,828	41 755 10
4	Pin, camshaft 37,39,826,828	47 380 09	12	Rotator 39	52 413 01
5	Valve, exhaust 37,39,826,828	235838	12	Rotator (Replaced by 52 413 01) 826,828	230020
6	Valve, intake 37,39,826	235008	13	Spring, exhaust valve 39,826,828	235168
6	Valve, intake 828	235582	14	Plug, cup 1/2" O.D. 37,39,826,828	X-702-3

**Group 5  
CARBURETOR**

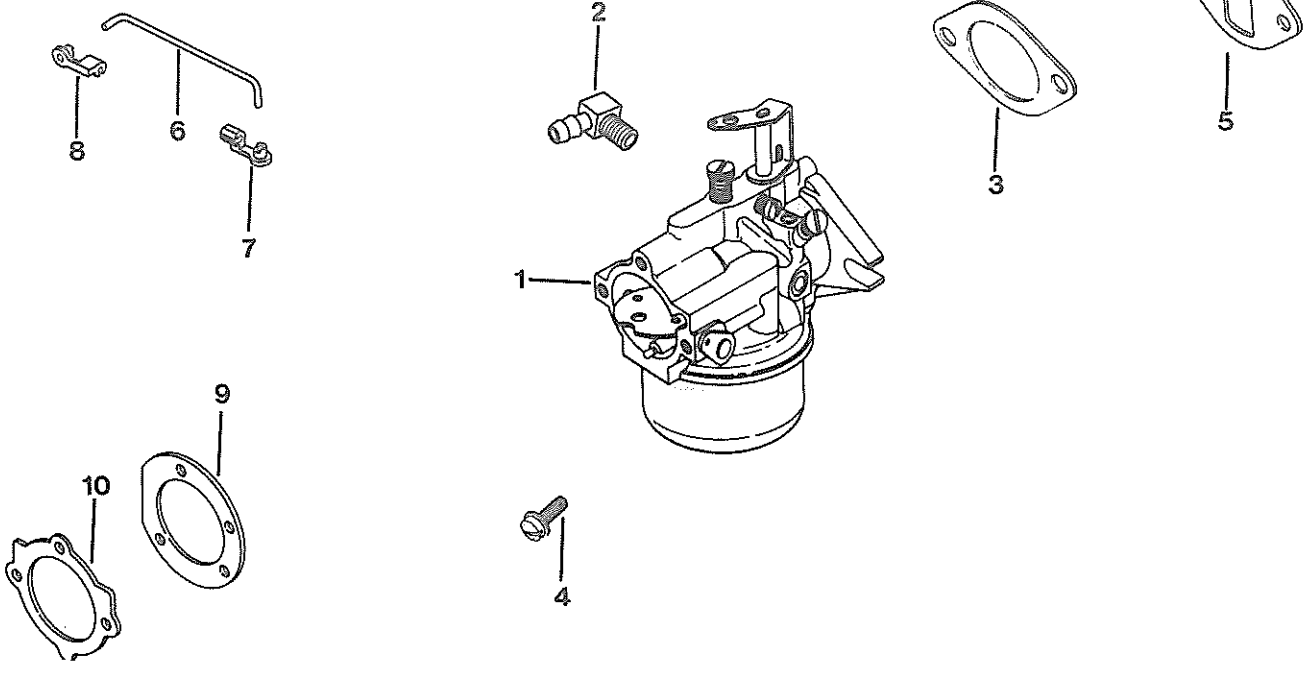

Index Number	Description Variation Number	Part Number	Index Number	Description Variation Number	Part Number
<p>Refer to Section 3 of Carburetor Reference Manual TP-2377-C for breakdown of the following carburetor assemblies:</p>					
1	Carburetor assembly		1	Carburetor assembly	
	1			156,300	
	Before Serial No. 1725405693 use:			Before Serial No. 1727207134 use:	
	Adjustable jet assembly	47 053 13		Adjustable jet assembly	
	After Serial No. 1725405683 use:			(Includes 9)	47 053 40
	Kit, fixed jet w/linkage			After Serial No. 1727207133 use:	
	(Includes Carburetor marked 47 053 67*			Kit, fixed jet	
	and 3,5,6,7,8,10)	47 853 02		(Includes Carburetor marked 47 053 74*	
	- or use -			and 3,9)	47 853 10
	Kit, variable jet w/linkage			- or use -	
	(Includes Carburetor marked 47 053 88*			Kit, variable jet	
	and 3,5,6,7,8,10)	47 853 22		(Includes Carburetor marked 47 053 91*	
				and 3,9)	47 853 25
1	Carburetor assembly		1	Carburetor assembly	
	144,153			157	
	Before Serial No. 1725300013 use:			Before Serial No. 1726700013 use:	
	Adjustable jet assembly			Adjustable jet assembly	
	(Includes 9)	47 053 62		(Includes 10)	47 053 80
	After Serial No. 1725300003 use:			After Serial No. 1726700003 use:	
	Kit, fixed jet w/linkage			Kit, fixed jet	
	(Includes Carburetor marked 47 053 65*			(Includes Carburetor marked 47 053 84*	
	and 3,5,6,7,8,9)	47 853 09		and 3,10)	47 853 18
	- or use -			- or use -	
	Kit, variable jet w/linkage			Kit, variable jet	
	(Includes Carburetor marked 47 053 86*			(Includes Carburetor marked 47 053 93*	
	and 3,5,6,7,8,9)	47 853 20		and 3,10)	47 853 27

Index Number	Description Variation Number	Part Number	Index Number	Description Variation Number	Part Number
1	Carburetor assembly 163 Kit, variable jet w/linkage (Includes Carburetor marked 47 053 88* and 3,5,6,7,8)	47 853 22	3	Gasket, carburetor 1,144,153,156,157,163,300	47 049 01
1	Carburetor assembly 164 Before Serial No. 1727207134 use: Adjustable jet assembly - or use - Kit fixed jet (Includes Carburetor marked 47 053 74* and 3,9) - or use - Kit, adjustable jet (Includes Carburetor marked 47 053 91* and 3,9) After Serial No. 1727207124 use: Carburetor assembly (Includes Carburetor marked B-236448*) (See next page)	47 053 40 47 853 10 47 853 25 B-237199	4	Screw, sltd. hd. 5/16-18 x 1" (2) 1,144,153,156,157,163,164,300	X-770-1
2	Connector, 90° hose (For 1/4" I.D. rubber hose) 1,144,153,156,157,163,300	25 155 02	5	Gasket, carburetor 1,144,153,163,164	271030
			6	Linkage, governor 1	47 079 11
			6	Linkage, governor 144,153	47 079 10
			7	Bushing, linkage (white) 1,144,153	47 158 07
			8	Bushing, linkage (black) 1,144,153	25 158 09
			9	Gasket, air cleaner 144,153,156,300	45 041 07
			10	Gasket, air cleaner 1,157	275341

\* Marked numbers are for information only,  
not available separately.

# M12

## CARBURETOR (Cont'd)

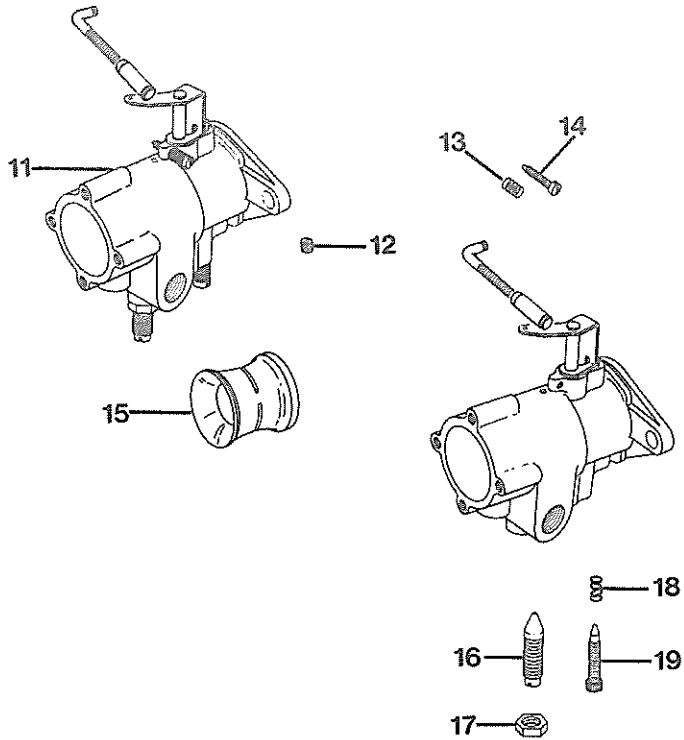

Index Number	Description Variation Number	Part Number	Index Number	Description Variation Number	Part Number
11	Carburetor assembly (Includes 12 - 19) (Use after engine Serial No. 1727207124) 164	B-237199	16	Screw, load adjustment (Discontinued not available at Kohler Co.) 164	236552
12	Screw, venturi set (Discontinued not available at Kohler Co.) 164	X-60-1	17	Nut, load adjustment (Discontinued not available at Kohler Co.) 164	236553
13	Spring, throttle lever adjusting screw 164	232555	18	Spring, idle adjustment 164	234208
14	Screw, throttle lever adjusting 164	232556	19	Screw, idle adjustment 164	234206
15	Venturi 164	236666			



# M12

## Group 7 CRANKCASE

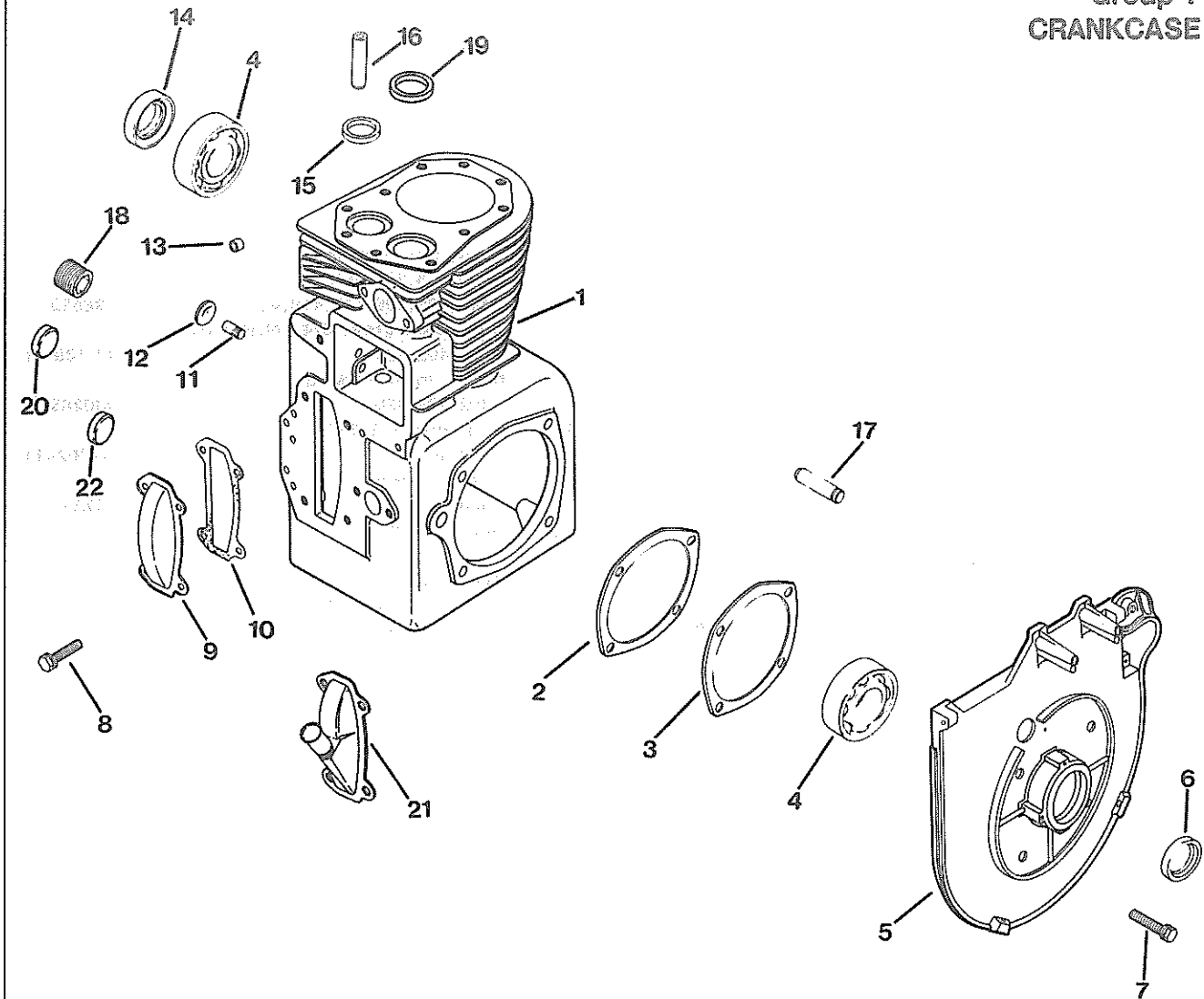

Index Number	Description Variation Number	Part Number	Index Number	Description Variation Number	Part Number
1	Cylinder block (Service w/SHORT BLOCK or MINIBLOCK. Refer to M12 Selection Guide TP-2250-C.)		5	Plate, bearing (Replaced by 47 146 11) 375,378,381,383,394,397,401, 402,404,405,406,411	47 146 07
2	Gasket, shim (A.R.) 375,378,381,383,394,397,401, 402,404,405,406,411,412,417,418, 419,420,423,424	47 422 05	5	Plate, bearing 417,418,419,420,423,424	47 146 11
3	Gasket, bearing plate 375,378,381,383,394,397,401,402, 404,405,406,411,412,417,418,419, 420,423,424	47 041 09	6	Seal, front oil 375,378,381,383,394,397,401, 402,404,405,406,411,417,418, 419,420,423,424	47 032 06
4	Bearing, ball (2) 375,378,381,383,394,397,401, 402,404,405,406,411,412,417,418, 419,420,423,424	235376	7	Screw, H.C. sems 3/8-16 x 1" (4) 375,378,381,383,394,397,401, 402,404,405,406,411,412,417,418, 419,420,423,424	X-159-2
			8	Screw, H.C. sems 1/4-20 x 5/8" (4) 375,378,381,401,404,411,412, 417,418,419	X-132-5

**CRANKCASE**  
**(Cont'd)**

**M12**

Index Number	Description Variation Number	Part Number	Index Number	Description Variation Number	Part Number
8	Screw, H.C. sems 1/4-20 x 1/2" (4) 383,394,397,402,405,406,420, 423,424	X-132-6	15	Insert, exhaust valve 375,378,381,383,394,397,401, 402,404,405,406,411,412,417,418, 419,420,423,424	230170
9	Cover, camshaft 375,378,381,383,394,397,401, 405,406,411,412,417,418,419, 420,423,424	235026	16	Guide, valve (2) 375,378,381,383,394,397,401, 402,404,405,406,411,412,417,418, 419,420,423,424	235007-S
10	Gasket, camshaft cover 375,378,381,383,394,397,401, 402,404,405,406,411,412,417,418, 419,420,423,424	235025	17	Shaft, balance gear (2) 375,378,381,383,394,397,401, 404,405,406,412,418,420,424	236559
11	Shaft, governor gear 375,378,381,383,394,397,401, 402,404,405,406,411,412,417,418, 419,420,423,424	235125-S	18	Plug, hex. ctsk. 3/4" N.P.T.F. 397,402,424	47 139 01
12	Plug, expansion 375,378,381,383,394,397,401, 402,404,405,406,411,412,417,418, 419,420,423,424	X-230-11	19	Insert, intake valve 402,404,420	230265
13	Bearing, governor cross shaft 375,378,381,383,394,397,401, 402,404,405,406,411,412,417,418, 419,420,423,424	234866	20	Plug, cup 1-1/16" 397,404	X-702-14
14	Seal, rear oil 375,378,381,383,394,397,401, 402,404,405,406,411,412,417,418, 419,420,423,424	47 032 07	21	Cover, camshaft 404	237623
			22	Plug, cup (2) 411,417,419,423	X-702-3
				NOT ILLUSTRATED	
				Washer, plain 1/4" (Hold ground lead) 404,420	X-25-63

# M12

## Group 8 CRANKSHAFT

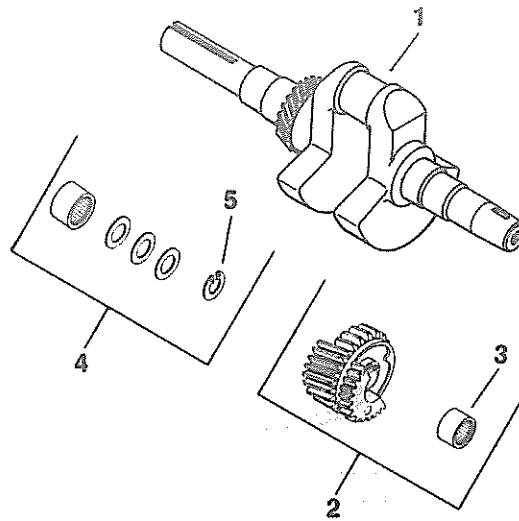

Index Number	Description Variation Number	Part Number	Index Number	Description Variation Number	Part Number
1	Kit, crankshaft (Replaced by 47 142 44) (1" dia. x 3") 10	47 142 23*	1	Kit, crankshaft (1" dia. x 3-7/16") 168	47 142 29*
1	Kit, crankshaft (1" dia. x 3-9/16") 31	47 142 26*	1	Kit, crankshaft (1" dia. x 3") 169	45 142 25*
1	Kit, crankshaft (1-1/8" dia. x 3-25/32", Standard basic) 148,166	47 142 16*	1	Kit, crankshaft (1-1/8" dia. x 3-25/32") 170	47 142 45*
1	Kit, crankshaft (Tapered end x 4-1/8", Basic generator) 157,173	47 142 37*	1	Kit, crankshaft (1" dia. x 3") 172	47 142 30*
1	Kit, crankshaft (1" dia. x 3-7/16", Basic pump) 158	47 142 35*	1	Kit, crankshaft (1" dia. x 3") 174	47 142 27*
1	Kit, crankshaft (1-1/8" dia. x 2-27/64", Basic gear reduction) 159	47 142 20*	2	Gear assembly (2) (Includes 3) 31,148,157,158,159,161,162, 167,168,169,170,172,174,176,177	45 043 03
1	Kit, crankshaft (1-1/8" dia. x 2-25/32") 161	47 142 32*	3	Bearing, needle (2) 31,148,157,158,159,161,162, 167,168,169,170,172,174,176,177	47 030 01
1	Kit, crankshaft (1" dia. x 2-57/64") 162	47 142 34*	4	Kit, spacer (Includes 5) 31,148,157,158,159,161,162, 167,168,169,170,172,174,176,177	47 755 01
1	Kit, crankshaft (3-step, 1-1/8" dia., 7/8" dia., 3/4" dia. x 3-3/16") 167	47 142 25*	5	Retainer (2) 31,148,157,158,159,161,162, 167,168,169,170,172,174,176,177	X-269-34
1	Crankshaft (1-1/2" dia. x 2-1/2") 176	47 014 84			
1	Kit, crankshaft (1" dia. x 1-27/64") 177	47 142 22*			

\*Crankshaft contains internal fastening threads. Kits include flywheel fastening hardware (a woodruff key, washer, screw and drive cup bushing). See flywheel group for part numbers. Crankshaft dimensions listed are for PTO end, from the face of block out.

# M12

## Group 9 CYLINDER HEAD

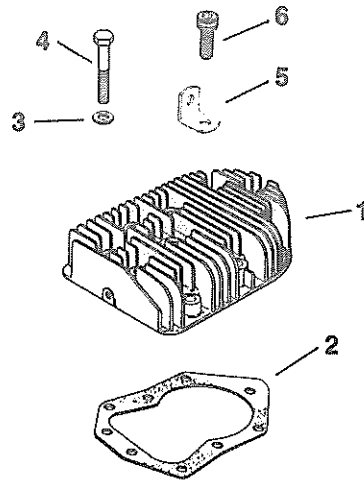

Index Number	Description Variation Number	Part Number	Index Number	Description Variation Number	Part Number
1	Head, cylinder 105	47 015 06	4	Screw, H.C. 3/8-16 x 1-1/2" (8) 105	270158
2	Gasket, head (Replaced by 47 041 15) 105	47 041 10	5	Strap, lifting 105	47 445 02
3	Washer, plain 3/8" (9) 105	270889	6	Screw, hex. hd. 3/8-16 x 1" 105	47 086 17

Group 10  
DIPSTICK

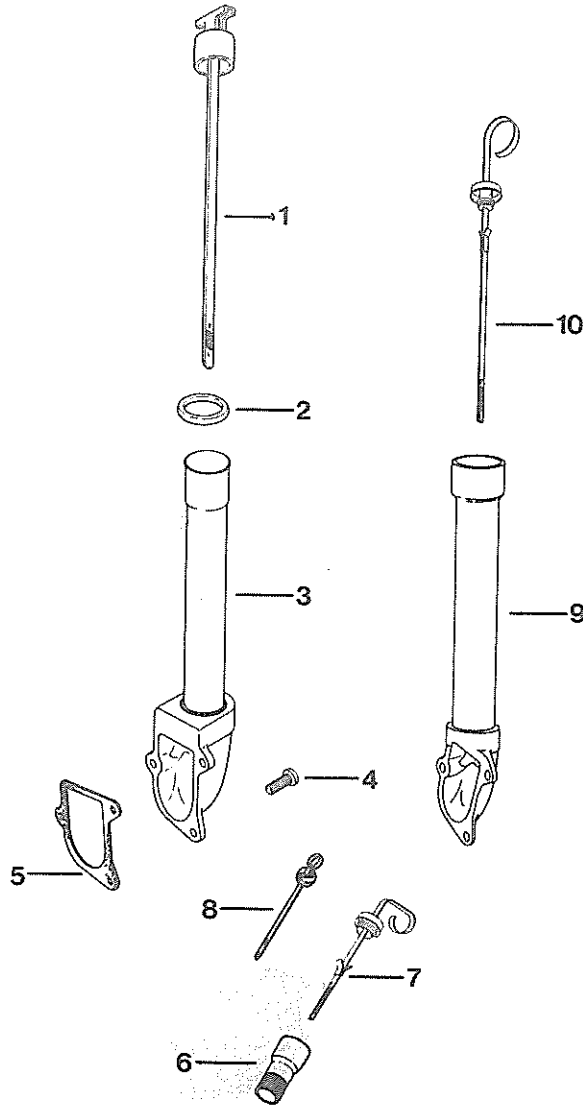

Index Number	Description Variation Number	Part Number	Index Number	Description Variation Number	Part Number
1	Dipstick (15-5/8" blade) 68	47 038 26	6	Tube, oil fill (1-13/16" lg.) 28	47 123 08
1	Dipstick (15-3/8" blade) 69	47 038 27	7	Dipstick (4-3/4" blade) 28	237013
2	O-Ring (51/64" I.D.) 68,69	41 153 01	8	Dipstick (8-31/32" blade) (Tube included w/camshaft cover) 48	237932
3	Adapter, oil fill 68,69	47 029 06	9	Tube, oil fill (8-5/8" lg.) 65	47 180 05
4	Screw, F.H. sems 10-24 x 1/2" (3) 65,68,69	X-131-2	10	Dipstick (13-7/64" blade) 65	45 272 04
5	Gasket, adapter 65,68,69	237064			

Group 11  
ELECTRIC START

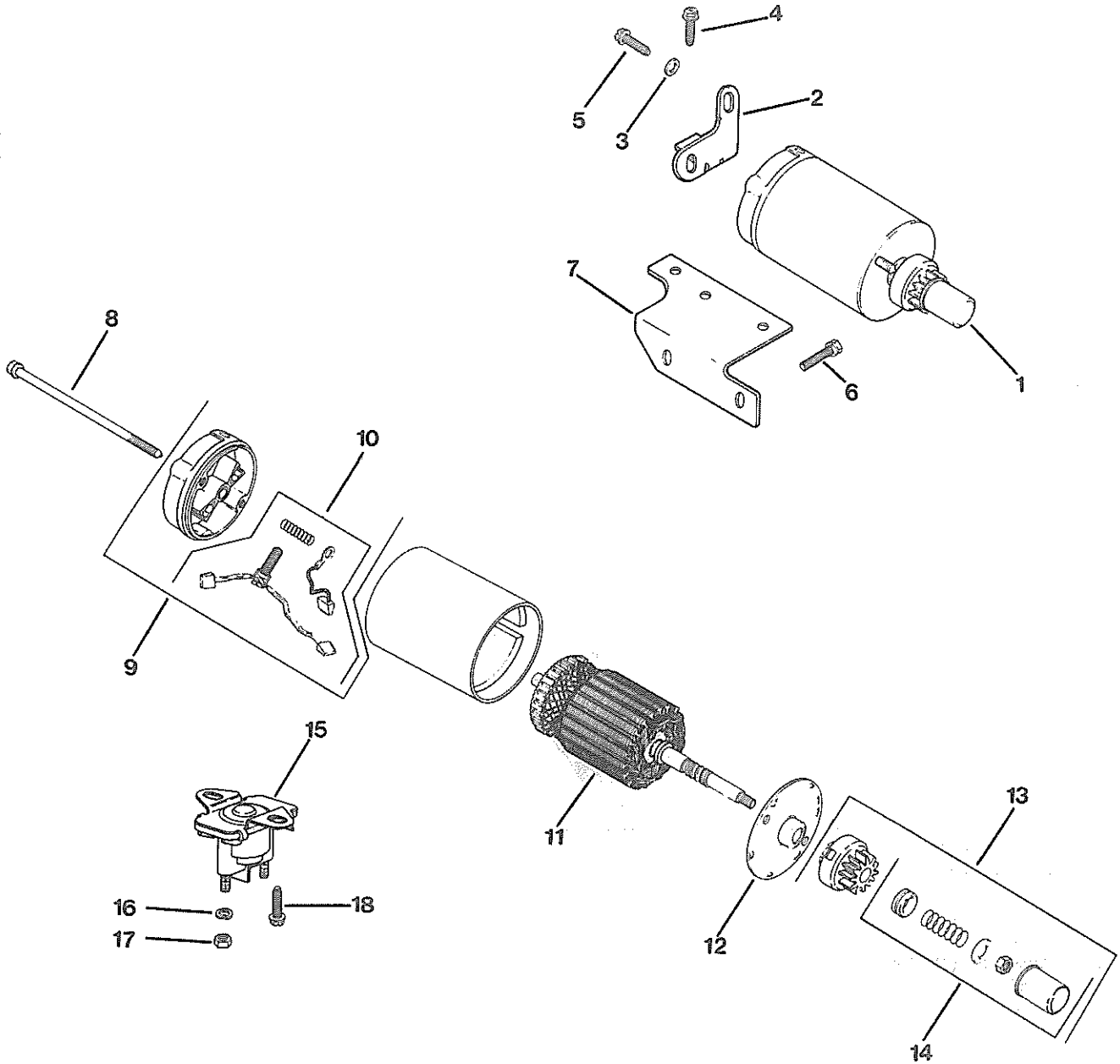

Index Number	Description Variation Number	Part Number	Index Number	Description Variation Number	Part Number
1	Starter assembly (Includes 8 - 14) 76,77,78,79,80,83,84,300	41 098 04	14	Kit, drive parts 76,77,78,79,80,83,84,300	47 755 13
2	Brace, tail 76,77,78,79,80,83,84,300	47 126 17	15	Solenoid (one tab terminal) 76,80,84,300	52 435 01
3	Washer, plain 1/4" 76,77,84,300	X-25-78	15	Solenoid (two tab terminals) 83	45 435 07
4	Screw, hex. wash. hd. 1/4-20 x 3/8" 77,78,79,80,83,300	X-67-83	16	Washer, lock 1/4" (2) 76,80,83,84,300	X-20-1
4	Screw, hex. wash. hd. 1/4-20 x 3/4" 78,79,80,83	X-67-62	17	Nut, hex. 1/4 - 20" (2) 76,80,83,84,300	X-81-1
5	Screw, hex. wash. hd. 1/4-20 x 3/4" (2) 76,77,84,300	X-67-62	18	Screw, hex. wash. hd. 1/4-20 x 3/8" (2) 76,80,83,84,300	X-67-83
6	Screw, H.C. sems 3/8-16 x 1" (2) 78,79,80,83	X-159-2	NOT ILLUSTRATED		
7	Bracket, solenoid 78,79,80,83	47 126 29		Tag, caution 76,77,78,79,80,83,84,300	25 450 03
8	Bolt, thru 1/4-20 x 5-1/16" (2) 76,77,78,79,80,83,84,300	41 086 19		Lubricant 76,77,78,79,80,83,84,300	52 357 01
9	Cap, commutator end assembly (Includes 10) 76,77,78,79,80,83,84,300	41 227 04		Lead, black, starter to solenoid (6" - 6 gauge - insulated barrel eyelet terminals) 76,80,83,84	52 518 03
10	Kit, brush 76,77,78,79,80,83,84,300	52 755 15		Lead, red, solenoid ground (3" - 18 gauge - insulated barrel eyelet, insulated push-on tab terminals) (Use on solenoids w/two tab terminals) 76,80,84,300	25 518 20
11	Armature 76,77,78,79,80,83,84,300	45 170 02		Decal, warning (white) 79	237447
12	Cap, drive end 76,77,78,79,80,83,84,300	41 227 03		Decal, 12 volt warning (white) 79	277356
13	Kit, drive (Includes 14) 76,77,78,79,80,83,84,300	47 755 07			

# M12

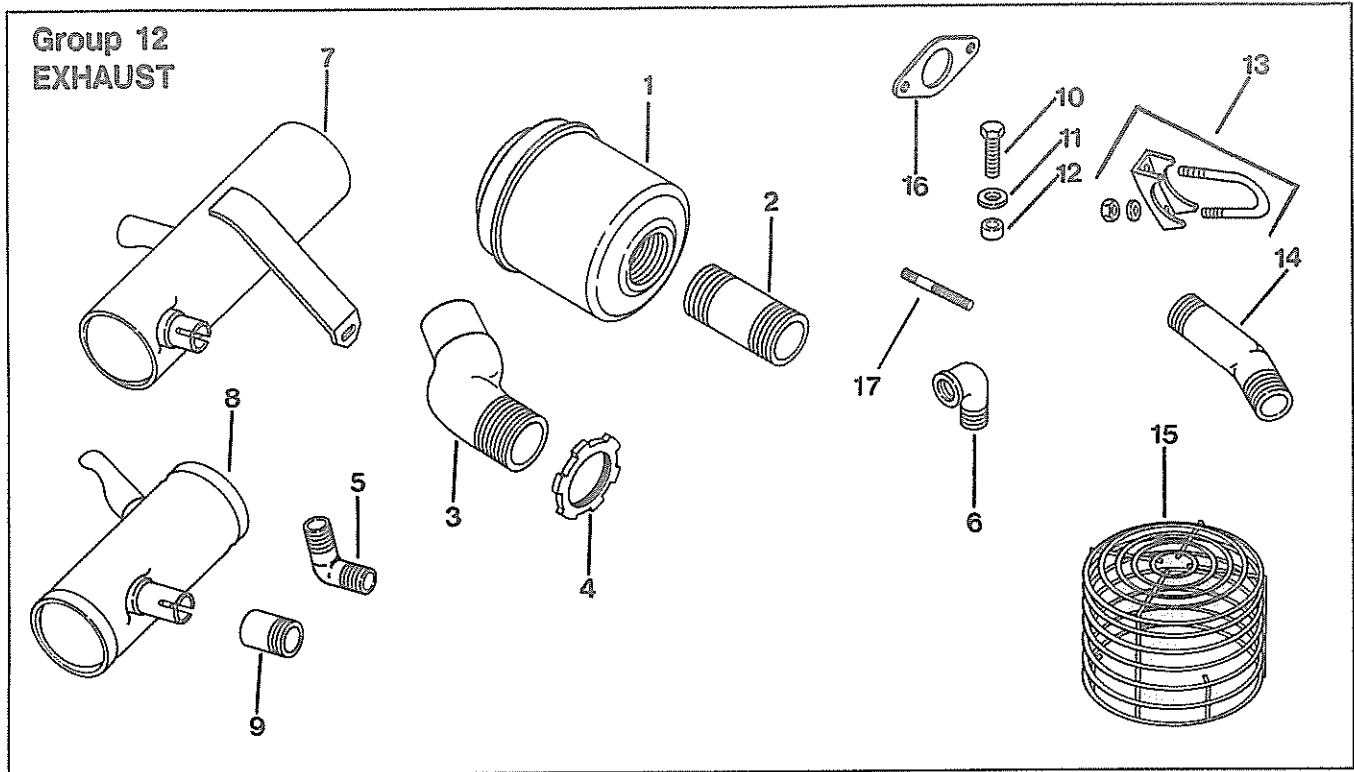

Index Number	Description Variation Number	Part Number	Index Number	Description Variation Number	Part Number
1	Muffler 1, 11, 53, 300, 305, 307, 308	275679	7	Muffler 50, 301, 302	47 068 15
2	Nipple 3" 1	41 136 02	8	Muffler 303, 304	47 068 14
2	Nipple 6" 304, 305, 307	25 136 05	9	Pipe 2-1/4" 303	X-229-11
2	Nipple 6" (Use after serial no. 2123600003) 308	25 136 05	10	Screw, 5/16-18 x 1-3/8" 50, 302	41 086 15
3	Elbow, exhaust 39, 50, 302	47 054 01	11	Washer, 5/16" 50, 302	X-25-20
4	Nut, lock 11, 39, 45, 50, 53, 300, 302	AC-1536	12	Spacer 50, 302	X-400-71
4	Nut, lock (Use before serial no. 2123600013) 308	AC-1536	13	Clamp 50, 302	237548
5	Elbow, exhaust (Use before serial no. 2123600013) 308	231820	13	Clamp 303, 304	47 237 04
5	Elbow, exhaust 11	231820	14	Elbow, exhaust 53	236347
6	Elbow, exhaust 45	230600	15	Guard, muffler 53	25 314 01
			16	Gasket, exhaust 306, 308	235122
			17	Stud (2) 308	41 072 19



Group 13  
FLYWHEEL

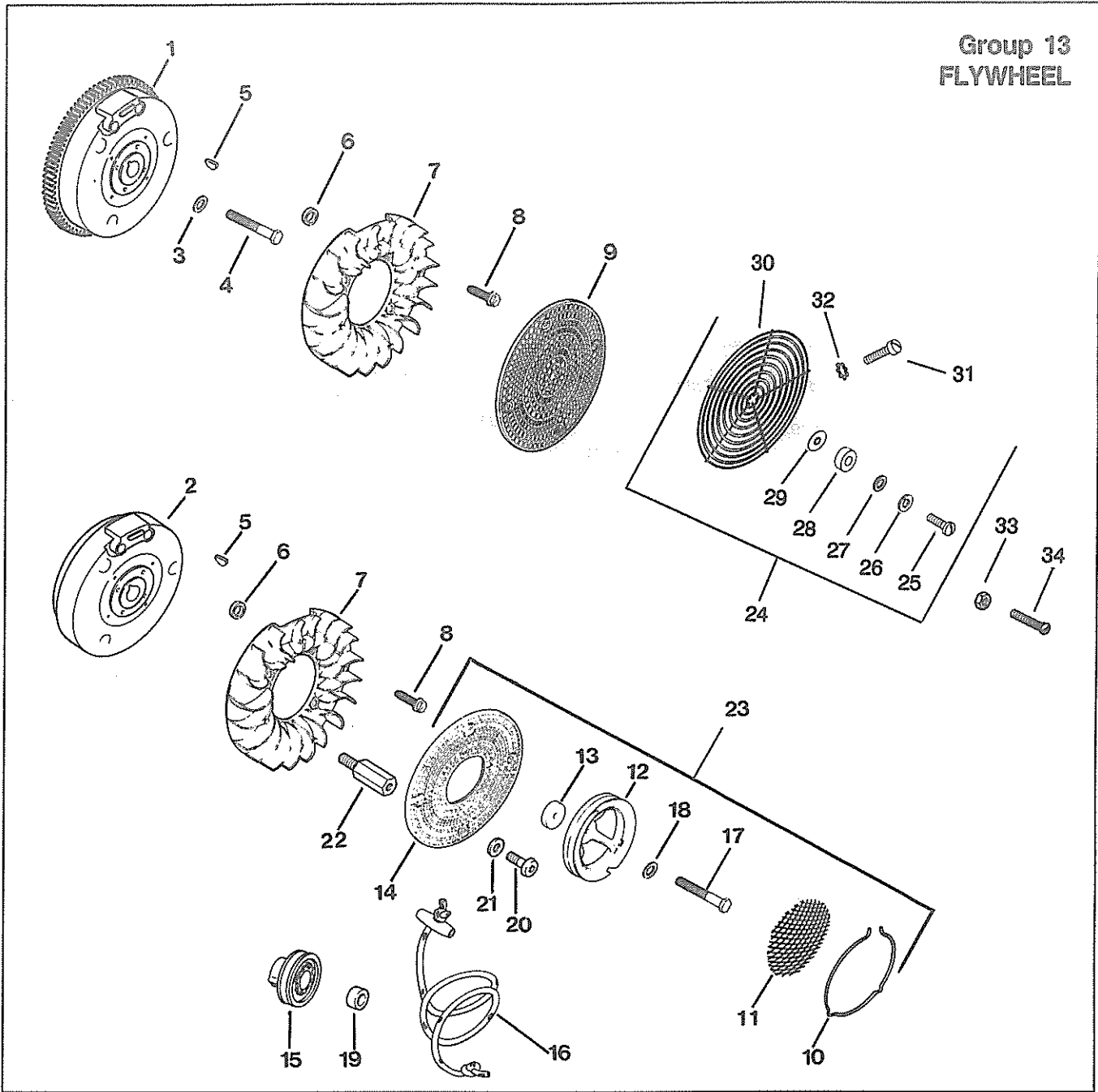

Index Number	Description Variation Number	Part Number	Index Number	Description Variation Number	Part Number
1	Flywheel 216,224,283,294,301,618	47 025 53	3	Washer, plain 13/32" I.D., 1-3/8" O.D. 215,216,219,223,224,244,284, 285,286,290,294,297,298,299, 301,618	52 468 15
1	Flywheel 223	47 025 57	4	Screw, hex. mach. 3/8-24 x 1-1/8" 215,216,219,223,224,244,284, 285,286,290,294,297,298,299, 301,618	25 086 24
1	Flywheel 244	47 025 58	5	Key, woodruff 3/16 x 1" 215,216,219,223,224,244,283,284, 285,286,290,294,295,297,298,299, 301,617,618	X-46-3
1	Flywheel 285,286,297,298	47 025 63			
2	Flywheel 215,284,290,295,299	47 025 56			
2	Flywheel 219,617	47 025 54			

Index Number	Description Variation Number	Part Number	Index Number	Description Variation Number	Part Number
6	Spacer 17/64" I.D., 3/8" O.D., 15/64" lg. (4) 215,216,219,223,224,244,283, 284,285,286,290,294,295,297, 298,299,301,617,618	25 112 04	19	Bushing 215,223,284	47 158 05
7	Fan (w/4 knobs for plastic grass screen) 215,216,219,223,224,244,283, 285,286,294,295,297,298,299, 301,617,618	25 157 01	20	Screw, truss hd. nylok 1/4-20 x 5/8" (4) 290	47 086 08
7	Fan (w/o knobs for plastic grass screen) 284,290	25 157 02	21	Washer, plain 17/64" (4) 290	X-25-52
8	Screw, hex. wash. hd. 1/4-20 x 5/8" (4) 215,216,219,223,224,244,283, 284,285,286,290,294,295,297, 298,299,301,617,618	25 086 21	22	Stud, hex. (4) 290	47 072 13
9	Screen, grass 216,219,294,301	25 162 01	23	Kit, rope start pulley (Includes 10-14,16-18 and decal 25 113 06) 283,295,617	47 755 29
10	Retainer 283,295,617	230363	24	Kit, fixed grass screen (Includes 25-32) 294,301	47 755 37
11	Screen 283,295,617	230098	25	Screw, R.H.M. 10-24 x 7/8" (5) 294,301	X-50-12 <sup>o</sup>
12	Pulley, rope start 283,295,617	47 093 01	26	Washer, lock #10 (5) 294,301	X-19-1 <sup>o</sup>
13	Spacer 13/32" I.D., 1-3/4" O.D., 7/16" lg. 283,295,617	47 112 18	27	Washer, flat (5) 294,301	25 468 03
14	Screen, grass (3-5/16" hole) (Replaced by 25 162 02) 215,244,283,284,285,286,295	25 162 02	28	Spacer (5) 294,301	25 112 08
14	Screen, grass (3-1/2" hole) (plastic) 223,617,618	41 162 02	29	Diaphragm (5) 294,301	220074
14	Kit, grass screen (metal) (Includes 20,21,22) 290	47 755 40	30	Guard, grass screen 294,301	47 314 01
14	Screen, grass (2-1/2" hole) 297,298,299	25 162 04	31	Screw, sltd. F.H. (5) 294,301	25 086 36*
15	Kit, front drive cup (Includes 3) 223	52 755 61	32	Washer, E.T. #10 (5) 294,301	X-22-22*
16	Rope 283,295,617	A-230099	33	Screw, R.H.M. (5) 294,301	X-50-7
17	Screw, hex. mach. 3/8-24 x 1-11/16" 283,295,617	25 086 25	34	Nut, elastic stop 10-24" (5) 294,301	X-101-9
18	Washer, plain 13/32" I.D., 1-1/4" O.D. 283,295,617	52 114 01	NOT ILLUSTRATED		
				Decal, rope start pulley 283,295,617	25 113 06
			<sup>o</sup> Note: To install guard to blower housings equipped with weld nuts.		
			*Note: To install guard to blower housings "not" equipped with weld nuts.		

# M12

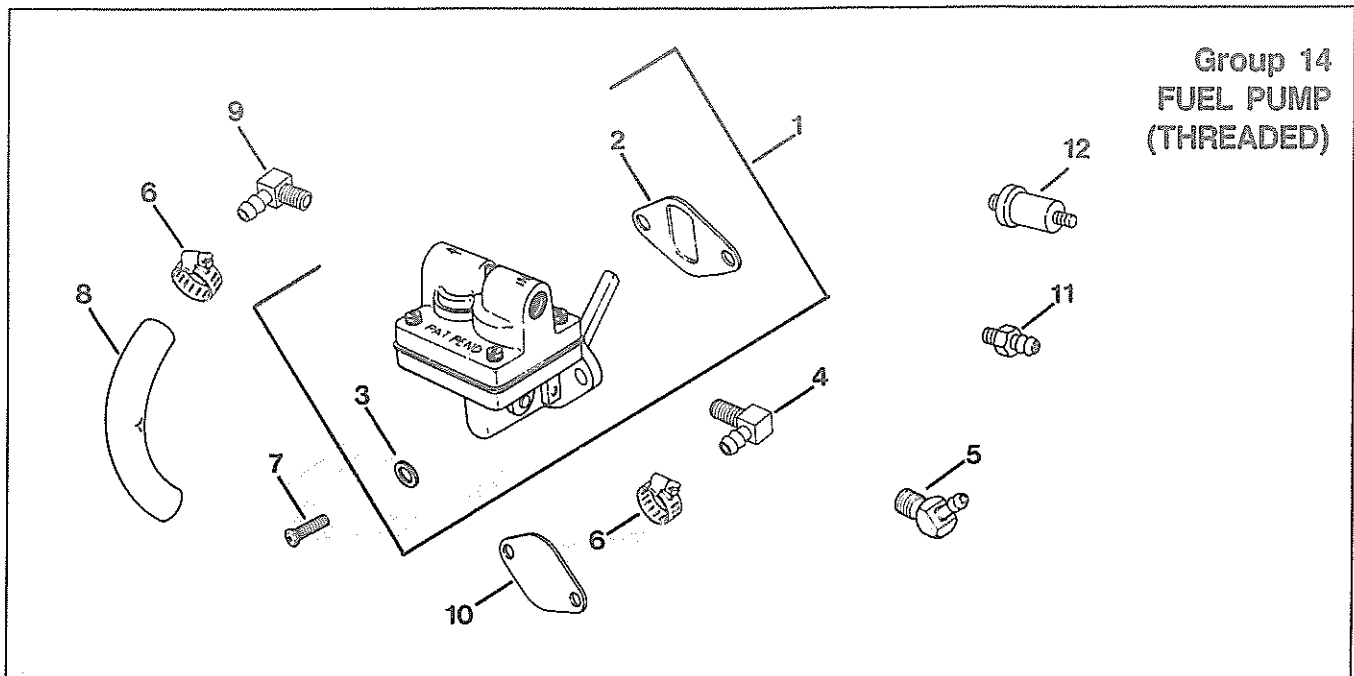

## Group 14 FUEL PUMP (THREADED)

Index Number	Description Variation Number	Part Number	Index Number	Description Variation Number	Part Number
1	Pump, fuel assembly (w/threaded fittings) (Includes 2,3,4,9) 51,106,302	47 559 01	6	Clamp, hose (4) 84,87,91,95,301	X-426-9
1	Pump, fuel assembly (w/threaded fittings) (Includes 2,3,4,5,9) 59,70,82,92,107,300,301,303	47 559 04	6	Clamp, hose 106	X-426-9
1	Pump, fuel assembly (w/threaded fittings) (Includes 2,3,4,9) 95	47 559 02	7	Screw, pozidriv F.H. sems 1/4-20 x 3/4" (2) 4,51,59,70,82,91,92,95, 106,107,300,301,302,303	X-174-2
2	Gasket, fuel pump (use on metal body fuel pump applications) 4,51,59,70,82,91,92,93,95, 300,301,302,303	25 041 05	8	Line, fuel 5-1/2" lg. 51,59,70,82,91,92,93,300, 301,302,303	25 353 01
2	Gasket, fuel pump (use on non-metal body pump applications only) 4,51,59,70,82,91,92,93,95,106,107, 300,301,302,303	25 041 09	8	Line, fuel 9" lg. 91	25 353 10
3	Washer, plain 1/4" (2) 51,59,70,82,91,92,93,95, 106,107,300,301,302,303	X-25-63	8	Line, fuel 6-1/4" lg. 95	25 353 04
4	Connector, 90° threaded (For 1/4" I.D. rubber hose) 51,59,70,82,91,92,95,107, 300,301,302,303	25 155 02	8	Line, fuel 3" lg. 95, 301	25 353 02
5	Connector, 45° threaded (For 1/4" I.D. rubber hose) 82,107,300	47 155 12	8	Line, fuel 5" lg. 106	25 353 08
6	Clamp, hose (2) 51,59,70,82,92,93,300,302,303	X-426-9	9	Connector, 90° threaded (For 3/16" I.D. rubber hose) 70,107	X-391-11
			10	Cover, fuel pump 4	240282
			11	Connector 107	X-380-1
			11	Connector, straight threaded (For 1/4" I.D. rubber hose) 95	X-380-2
			12	Filter, fuel 91,95,301,303	25 050 01
			Note: Order fuel pump parts according to style of pump used on engine.		

**FUEL PUMP  
(Cont'd)  
(PRESS-IN)**

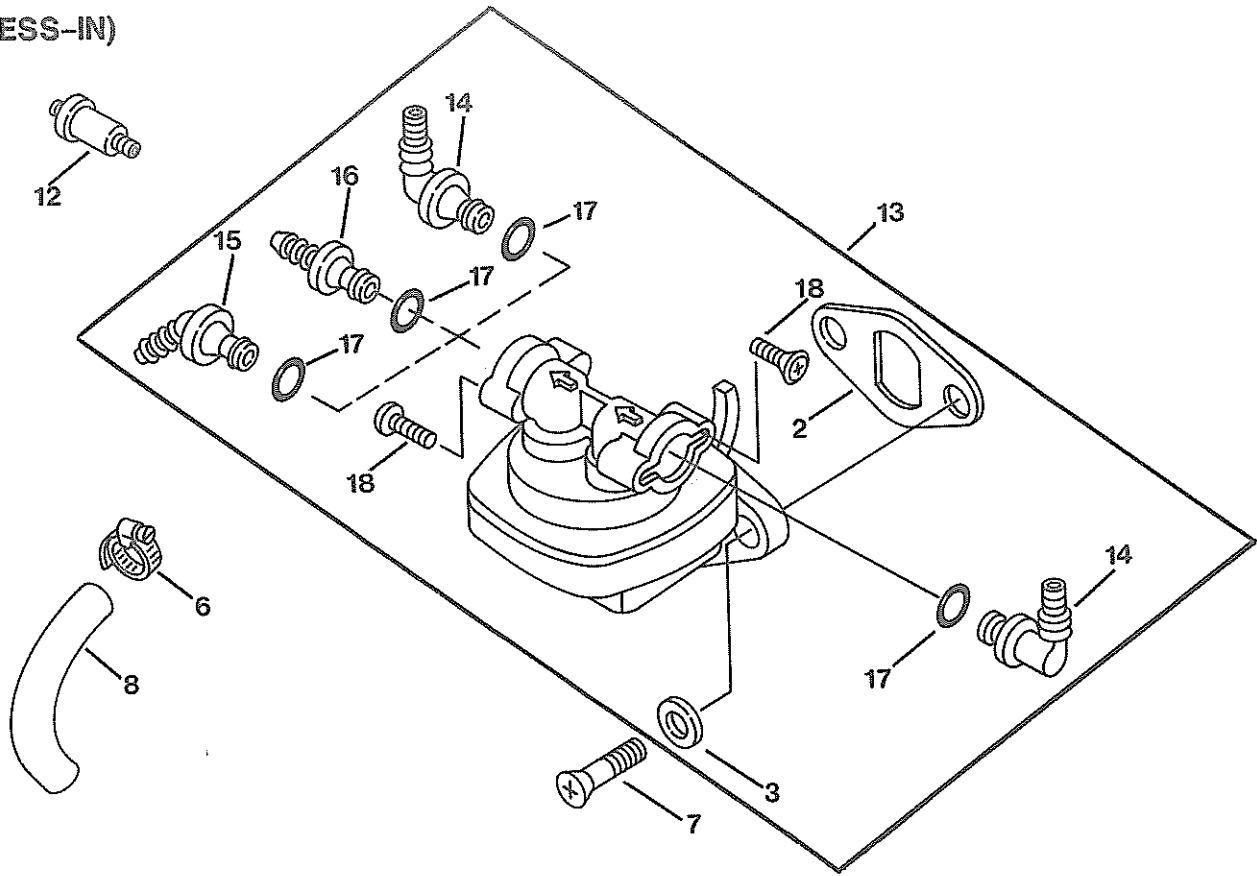

Index Number	Description Variation Number	Part Number	Index Number	Description Variation Number	Part Number
13	Pump, fuel assembly (w/press-in fittings) (Flow arrows go left to right) (Includes 2 - 8) (Replaced by 47 559 01)	51,302	16	Connector, straight press fit w/O-Ring (A.R.) (For 1/4" I.D. rubber hose)	25 294 03
		47 559 06	17	O-Ring	25 153 01
13	Pump, fuel assembly (w/press-in fittings) (Flow arrows go right to left as shown) (Includes 2-8) (Replaced by 47 559 04)	59,91,92,93,300,301,303	18	Screw, tapping (2)	25 086 35
14	Connector, 90° press fit w/O-Ring (A.R.) (For 1/4" I.D. rubber hose)	25 294 01	Note: Order fuel pump parts according to style of pump used on engine.		
15	Connector, 45° press fit w/O-Ring (A.R.) (For 1/4" I.D. rubber hose)	25 294 02			

# M12

## Group 15 FUEL TANK

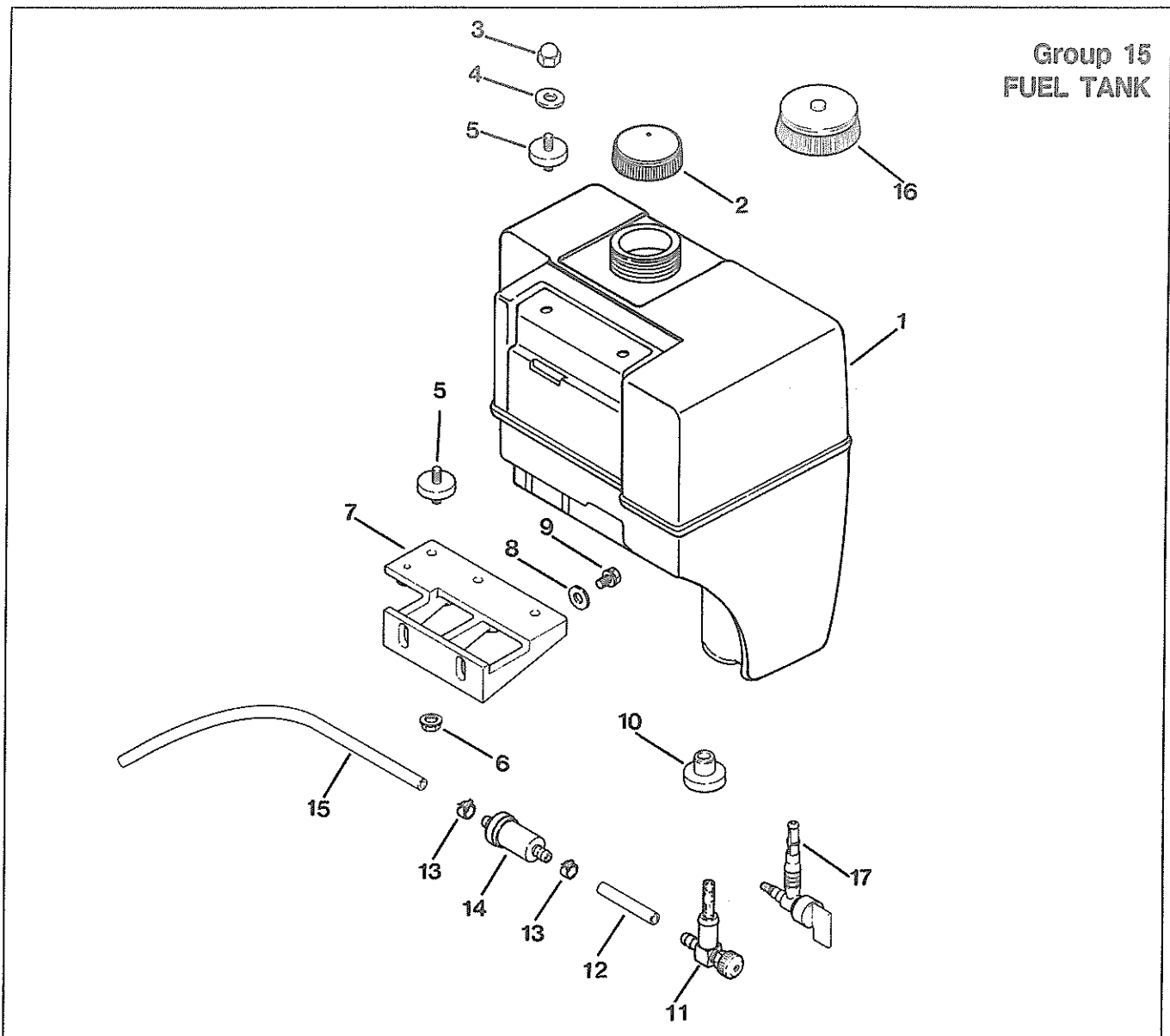

Index Number	Description Variation Number	Part Number	Index Number	Description Variation Number	Part Number
1	Tank, fuel (1/2" high filler neck) (Replaced by 47 755 39) 66,67,79,80,81,83,84,300,301	47 065 04	6	Palnut 1/4-20 (2) 66,67,79,80,81,83,84,300,301	X-799-1
1	Kit, fuel tank (Includes cap 25 173 03) (3/4" high filler neck) 66,67,79,80,81,83,84,300,301	47 755 39	7	Bracket, lower tank 66,67,79,80,81,83,84,300,301	47 126 30
2	Cap, fuel tank (Replaced by 25 173 02) (Used on tank w/1/2" high filler neck) 66,67,79,81,83,301	25 173 01	8	Washer, plain 3/8" (2) 66,67,79,80,81,83,84,300,301	X-25-28
3	Nut, acorn (2) 66,67,79,81,83,84,300,301	25 100 04	9	Screw, H.C. sems 5/16-18 x 1-1/8" (2) 66,67,79,80,81,83,84,300,301	X-159-3
4	Washer, plain 1/4" (2) 66,67,79,80,81,83,84,300,301	X-25-78	10	Bushing, fuel tank (Use with metal shut-off valve) 66,67,79,80,81,83,84,300,301	41 158 03
5	Mount, isolation (4) 66,67,79,80,81,83,84,300,301	47 366 01	10	Bushing, fuel tank (Use with plastic shut-off valve) 66,67,79,80,81,83,84,300,301	25 313 01
			11	Valve, fuel shut-off (metal) 66,67,79,80,81,83,84,300,301	25 462 01

**FUEL TANK  
(Cont'd)**

**M12**

Index Number	Description Variation Number	Part Number	Index Number	Description Variation Number	Part Number
12	Line, fuel 3/16" I.D., 2" lg. 66,79,80,84,300,301	41 353 10	16	Cap, fuel tank (Use on tank w/3/4" high filler neck) 66,67,79,80,81,83,84,300,301	25 173 03
13	Clamp, hose (2) 66,79,81,83,300,301	25 237 01	17	Valve, fuel shut-off (plastic) 66,67,79,80,81,83,84,300,301	25 462 03
13	Clamp, hose (4) 80,84	25 237 01	NOT ILLUSTRATED		
14	Filter, fuel 66,79,80,84,300,301	41 050 02		Decal, fuel warning 79,83,84,300,301	25 113 10
15	Line, fuel 3/16" I.D., 19" lg. 66,67,79,80,81,83,84,300,301	47 353 02			
16	Cap, fuel tank (Use on tank w/1/2" high filler neck) 66,67,79,80,81,83,84,300,301	25 173 02			

# M12

## Group 16 GEAR REDUCTION

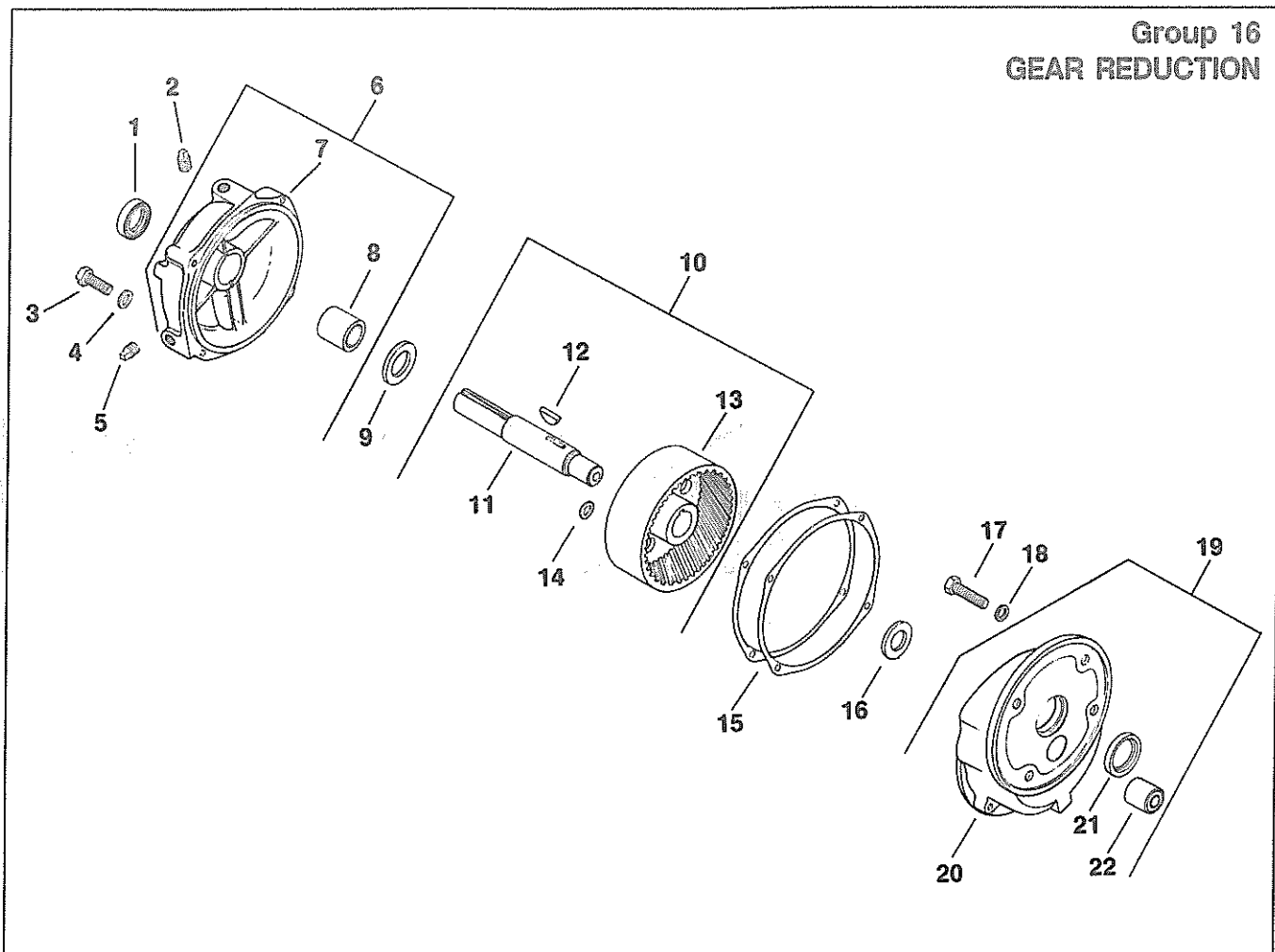

Index Number	Description Variation Number	Part Number	Index Number	Description Variation Number	Part Number
1	Seal, rear oil		12	Key, woodruff 3/16 x 1"	
	2	47 032 07	2		X-46-3
2	Plug, vented hex. ctsk. 3/4" N.P.T.F.		13	Gear, reduction	
	2	41 139 01	2		235245
3	Screw, H.C. 5/16-18 x 2" (4)		14	Washer, plain 3/8" (2)	
	2	X-6-29	2		X-25-67
4	Washer, lock 5/16" (4)		15	Gasket (A.R.)	
	2	X-21-1	2		234498
5	Plug, sq. hd. solid 1/4" N.P.T.F.		16	Washer, thrust	
	2	X-75-2	2		235248
6	Housing, gear assembly (Includes 7,8)		17	Screw, H.C. 3/8-16 x 1" (4)	
	2	A-237173	2		270677
7	Cover, gear		18	Washer, lock 3/8" (2)	
	2	235244	2		X-22-1
8	Bearing, needle		19	Housing, gear assembly (Includes 20-22)	
	2	235250	2		A-237174
9	Washer, thrust		20	Housing, gear	
	2	235247	2		235243
10	Shaft assembly (Includes 11 - 13)		21	Seal, front oil	
	2	A-237172	2		47 032 06
11	Shaft, reduction gear		22	Bearing, needle	
	2	235249	2		235251

# M12

## Group 17 GOVERNOR

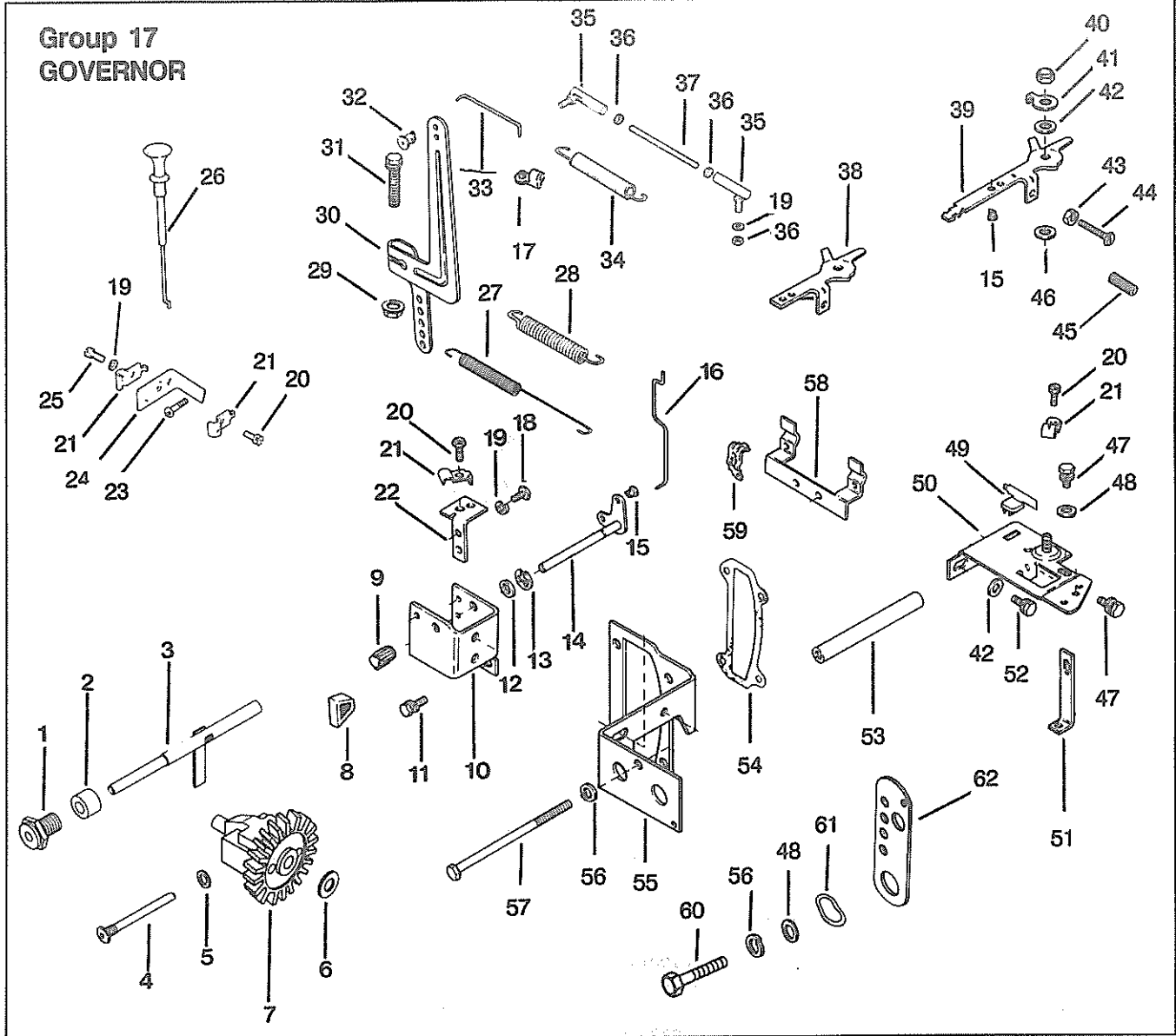

Index Number	Description Variation Number	Part Number	Index Number	Description Variation Number	Part Number
1	Bushing, governor shaft 68,79,81,95,96,97,98,100,104,107, 112,114,116,117,118,119,120,123, 127,140,148,149,151,152,153,160, 500,501	235476	4	Pin, governor stop 68,79,81,95,96,97,98,100,104,107, 112,114,116,117,118,119,120,123, 127,140,148,149,151,152,153,160, 500,501	231355
2	Spacer 17/64" I.D., 3/8" O.D., 13/16" lg. 68,79,81,95,96,97,98,100,104,107, 112,114,116,117,118,119,120,123, 127,140,148,149,151,152,153,160, 500,501	X-400-80	5	Washer, plain 1/4" 68,79,81,95,96,97,98,100,104,107, 112,114,116,117,118,119,120,123, 127,140,148,149,151,152,153,160, 500,501	25 468 01
3	Kit, governor shaft (Includes 2) 68,79,81,95,96,97,98,100,104,107, 112,114,116,117,118,119,120,123, 127,140,148,149,151,152,153,160, 500,501	A-235256-S	6	Washer, thrust 68,79,81,95,96,97,98,100,104,107, 112,114,116,117,118,119,120,123, 127,140,148,149,151,152,153,160, 500,501	237022



Index Number	Description Variation Number	Part Number	Index Number	Description Variation Number	Part Number
7	Kit, governor gear (Includes 6) 68,79,98,149,153,500	A-236294-S	14	Control assembly, choke (Includes 47 144 33) (Use after serial no. 2119100003) 500,501	47 144 34
7	Kit, governor gear (Includes 6) 81,95,96,97,100,104,107,112,114, 116,117,118,119,120,123,127,140, 148,151,152,160,501	A-235743-S	14	Control, assembly choke (Includes 47 144 33) 151,152,160	47 144 34
8	Knob, speed control 117,127,148,152,160,501	41 341 03	14	Shaft, choke control (Use after serial no. 2119100003) 500,501	47 144 33
8	Knob (2) 151	41 341 03	15	Bushing, linkage (black) (2) 79,116,117,118,127,148,151, 152,160,501	47 158 03
9	Knob, choke, w/set screw (Use with 47 144 20 shaft) (Use before SN 1811200013) 79,116,117,118,127,148	47 341 02	15	Bushing, linkage (black) 107,112,500	47 158 03
9	Knob, choke, w/set screw (Use with 47 144 23 shaft) (Use after SN 1811200003) 79,116,117,118,127,148	47 341 03	16	Linkage, choke (Carburetor to choke shaft) 79,116,117,118,148	47 079 04
9	Knob, choke, w/set screw 151,152,160,500,501	47 341 03	16	Linkage, choke (Use before serial no. 2119100013) 500,501	47 079 04
10	Bracket, choke shaft 79,116,117,118,127,148	47 126 25	16	Linkage, choke 151,152,160	47 079 16
10	Bracket, choke shaft (Use before serial no. 2119100013) 500,501	47 126 25	16	Linkage, choke (Use after serial no. 2119100003) 500,501	47 079 16
11	Screw, hex. hd. sems 10-24 x 3/8" (2) 79,116,117,118,127,148	41 086 23	17	Bushing, linkage 79,116,117,118,148,151,152, 160,500,501	25 158 09
11	Screw, hex hd. sems 10-24 x 3/8" (2) (Use before serial no. 2119100013) 500	41 086 23	17	Bushing, linkage 68,79,81,95,96,97,98,100,104,107, 112,114,119,120,123,140,148, 149,153	25 158 09
11	Screw, hex hd. sems 10-24 x 3/8" (4) (Use before serial no. 2119100013) 501	41 086 23	18	Screw, hex. hd. sems 10-24 x 3/8" (2) 116,117,118,127,148	41 086 23
12	Bushing, choke shaft (2) 79,116,117,118,127,148,151, 152,160,500,501	25 158 05	19	Washer, lock #10 (2) 68	X-19-1
13	E-ring (2) 79,116,117,118,127,148,151, 152,160,500,501	25 141 01	19	Washer, Lock #10 96,116,117,118,127,148	X-19-1
14	Shaft, choke control (Use with 47 341 02 knob) (Use before SN 1811200013) 79,116,117,118,127,148	47 144 20	19	Washer, lock #10 96	X-19-1
14	Shaft, choke control 151,152,160	47 144 33	20	Screw, sltd. hex hd. 10-24 x 3/8" (2) (Use before serial no. 2119100013) 501	X-97-3
14	Shaft, choke control (Use with 47 341 03 knob) (Use after SN 1811200003) (Replaced by 47 755 41 kit) 79,116,117,118,127,148	47 144 23	20	Screw, sltd. hex. hd. 10-24 x 3/8" (2) 116,117,118,127,148	X-97-3
14	Kit, choke shaft (Includes 9 [47 341 03], 13) 79,116,117,118,127,148	47 755 41	20	Screw, hex washer tap 10-24 x 13/32" (2) 160	X-67-97
14	Kit, choke shaft (Includes 9[47 341 03], 13) (Use before serial no. 2119100013) 500,501	47 755 41	20	Screw, hex washer tap 10-24 x 13/32" (2) (Use after serial no. 2119100003) 500	X-67-97

GOVERNOR  
(Cont'd)

M12

Index Number	Description Variation Number	Part Number	Index Number	Description Variation Number	Part Number
20	Screw, hex washer tap 10-24 x 13/32" (Before serial no. 2119100013 use [2], after serial no. 211910003 use [4]) 501	X-67-97	30	Lever, governor 79,81,95,96,97,98,100,104,107, 112,114,116,117,118,119,120, 127,140,148,149,151,152,153, 160,500,501	47 090 20
20	Screw, sltd hex. hd. 10-24 x 3/8" 97,98,119,149,153	X-97-3	30	Lever, governor (Includes 32,34) 123	A-237653
21	Clamp, cable (2) 116,117,118,127,148,149,160	235778	31	Screw, H.C. sems 1/4-20 x 1-1/4" 68,79,81,95,96,97,98,100,104,107, 112,114,116,117,118,119,120, 123,127,140,148,149,151,152, 153,160,500,501	X-776-1
21	Clamp, cable (4) 151,152	235778	32	Bushing, linkage 68,79,81,95,96,97,98,100,104,107, 112,114,116,117,118,119,120, 123,140,148,149,151,152,153, 160,500,501	47 158 07
21	Clamp, cable (2) (Use after serial no. 2119100003) 500	235778	33	Linkage, governor (gold) (Governor to carburetor) 68,123	47 079 11
21	Clamp, cable (Before serial no. 2119100013 use [2], after serial no. 2119100003 use [4]) 501	235778	33	Linkage, governor (silver) (Governor to carburetor) (Replaced by 47 079 10 gold linkage) 79,81,95,96,97,100,104,107, 112,114,116,117,118,119,120, 140,148	47 079 05
21	Clamp, cable 96,97,98,119,149,153	235778	33	Linkage, governor (Governor to carburetor) 98,149,151,152,153,160,500,501	47 079 10
22	Bracket, cable clamp 116,117,118,127,148	47 126 31	33	Linkage, governor 149	47 079 18
22	Bracket, cable clamp (Use before serial no. 2119100013) 501	47 126 31	34	Spring, dampening (93 coils) (Governor lever to carburetor) 79,149,153,160,500	230117
23	Screw, sems 1/4-20 x 5/8" 97,98,119,149,153	52 086 11	35	Ball joint (2) 68	237130
24	Bracket, choke 96	47 126 36	36	Nut, hex. 10-32 (6) 68	X-70-3
24	Bracket, choke 97,98,119,149,153	47 126 34	36	Nut, hex 10-32 (2) 98,119,149,153	X-70-3
25	Screw, F.H.M. 10-24 x 1/2" 96,149	X-15-5	37	Rod, throttle 68	235078
26	Cable, choke 97,98,119,149,153	47 159 01	38	Lever, speed control 79,118,160,500	47 090 22
27	Spring, governor (23 coils) 79,160,500	47 089 07	39	Lever, speed control 116,117,127,148,151,152,501	47 090 19
27	Spring, governor (34 coils) 97,100,107,114,120,140	47 091 01	40	Nut, hex lock 1/4-20 79,116,117,118,127,148	X-101-8
27	Spring, governor (34 coils) (Use after SN 1614100003) 104	47 091 01	40	Nut, jam 151,152,160,500,501	41 100 04
27	Spring, governor (26 coils) (Replaced by 47 089 09) 116,117,118,127	47 089 08	41	Tab, locking 79,116,117,118,127,148	52 448 01
27	Spring, governor (26 coils) 148,151,152,501	47 089 09	41	Tab, locking 151,152,160,500,501	52 448 02
28	Spring, governor (26 coils) 68,81,95,96,112,123	235496	42	Washer, plain 1/4" (2) 79,116,117,118,127,148	X-25-53
28	Spring, governor (26 coils) (Use before SN 1614100013) 104	235496	42	Washer, plain 1/4" 149,151,152,160	X-25-53
28	Spring, governor (23 coils) 98,119,149,153	45 091 01	42	Washer, plain 1/4" (2) (Use before serial no. 2119100013) 500,501	X-25-53
29	Palnut 1/4-20 68,79,81,95,96,97,98,100,104,107, 112,114,116,117,118,119,120, 123,127,140,148,149,151,152, 153,160,500,501	X-799-1			
30	Lever, governor (Includes 32,34) 68	A-237444			

Index Number	Description Variation Number	Part Number	Index Number	Description Variation Number	Part Number
42	Washer, plain 1/4" (Use before serial no. 2119100013 use Qty. (2), after serial no. 2119100003 use [1])		52	Screw, H.C. sems 1/4-20 x 5/8" (2) (Use before serial no. 2119100013)	
	500,501	X-25-53		501	X-132-5
42	Washer, plain 1/4" (Use after serial no. 2119100003)		53	Spacer 17/64" I.D., 1/2" O.D., 4-1/2" lg.	25 112 03
	500	X-25-78		79,116,117,118,127,148	
42	Washer, plain 1/4" 152,160	X-25-78	53	Spacer (Use before serial no. 2119100013)	25 112 03
43	Nut, hex. 10-24 79,116,117,118,127,148,152, 160,500,501	X-70-2		500,501	
43	Nut, hex 10-24 (2) 151	X-70-2	54	Gasket, camshaft cover 79,116,117,118,127,148	235025
44	Screw, F.H. 10-24 x 3/8" 79,116,117,118,127,148	X-50-7	54	Gasket, cam cover (Use before serial no. 2119100013)	235025
44	Screw, F.H. 10-24 x 3/8" (Use before serial no. 2119100013)			500,501	
	500,501	X-50-7	55	Bracket, control panel 79,116,117,118,127,148	47 126 28
45	Screw, set 10-24 x 1" 151,152,160	47 086 25	55	Bracket, control panel (Use before serial no. 2119100013)	47 126 28
45	Screw, set 10-24 x 1" (Use after serial no. 2119100003)			500,501	
	500,501	47 086 25	56	Washer, lock 1/4" 79,112,116,117,118,120, 127,140,148,149	X-20-1*
46	Washer, wave (1 curve) 76,118,151	41 468 03	56	Washer, lock 1/4" (2) 81,95,96,104	X-20-1
46	Washer, wave (2) (1 curve) 79,116,117,127,148,152, 500,501	41 468 03	56	Washer, lock 1/4" (Use before serial no. 2119100013)	X-20-1
47	Screw, H.C. sems 1/4-20 x 3/8" (2) 79,112,116,117,118,127,148	X-132-1		500,501	
47	Screw, H.C. sems 1/4-20 x 3/8" (2) (Use before serial no. 2119100013)		57	Screw, H.C. 1/4-20 x 5-1/16" 79,116,117,118,127,148	47 086 16
	500,501	X-132-1	57	Screw, H.C. 1/4-20 x 5-1/16" (Use before serial no. 2119100013)	47 086 16
48	Washer, plain 1/4" 79,114,116,117,118,120,123, 127,140,148	X-25-63*		500,501	
48	Washer, plain 1/4" (2) 68,95,96,98,104,112,119, 149,153	X-25-63	58	Bracket, bowden wire 79,116,117,118,127,148	47 126 26
48	Washer, plain 1/4" (Use before serial no. 2119100013)		58	Bracket, bowden wire (Use before serial no. 2119100013)	47 126 26
	500,501	X-25-63		500,501	
49	Switch, kill 117,148,151,501	25 099 12	59	Clip, cable (2) 68,79,98,116,117,118,119, 127,148,149,153	2325603
50	Bracket, speed control 79,116,117,118,127,148	47 126 21	59	Clip, cable (Use before serial no. 2119100013)	235603
50	Bracket, speed control (Use before serial no. 2119100013)			500,501	
	500,501	47 126 21	60	Screw, H.C. sems 1/4-20 x 1-1/4" (2) 68,97,98,107,112,114,119,123, 140,149,153	X-132-9
51	Bracket, stabilizer 79,116,117,118,127,148	47 126 27	60	Screw, H.C. 1/4-20 x 1-1/2" (2) 81,95,96,104	X-5-26*
51	Bracket, stabilizer (Use before serial no. 2119100013)		60	Screw, H.C. 1/4-20 x 1-1/2" 112,120	X-25-26
	500,501	47 126 27	61	Washer, wave (2 curves) 68,98,119,123,149,153	275690*
52	Screw, H.C. sems 1/4-20 x 5/8" (2) 79,116,117,118,127,148	X-132-5	61	Washer, wave (3) 81,95,96,104,112	275690*
			61	Washer, wave (2) 97,100,107,114,120,140	275690
			62	Bracket speed control 68,81,95,96,98,104,112,119, 123,149,153	235086*

# M12

## GOVERNOR (Cont'd)

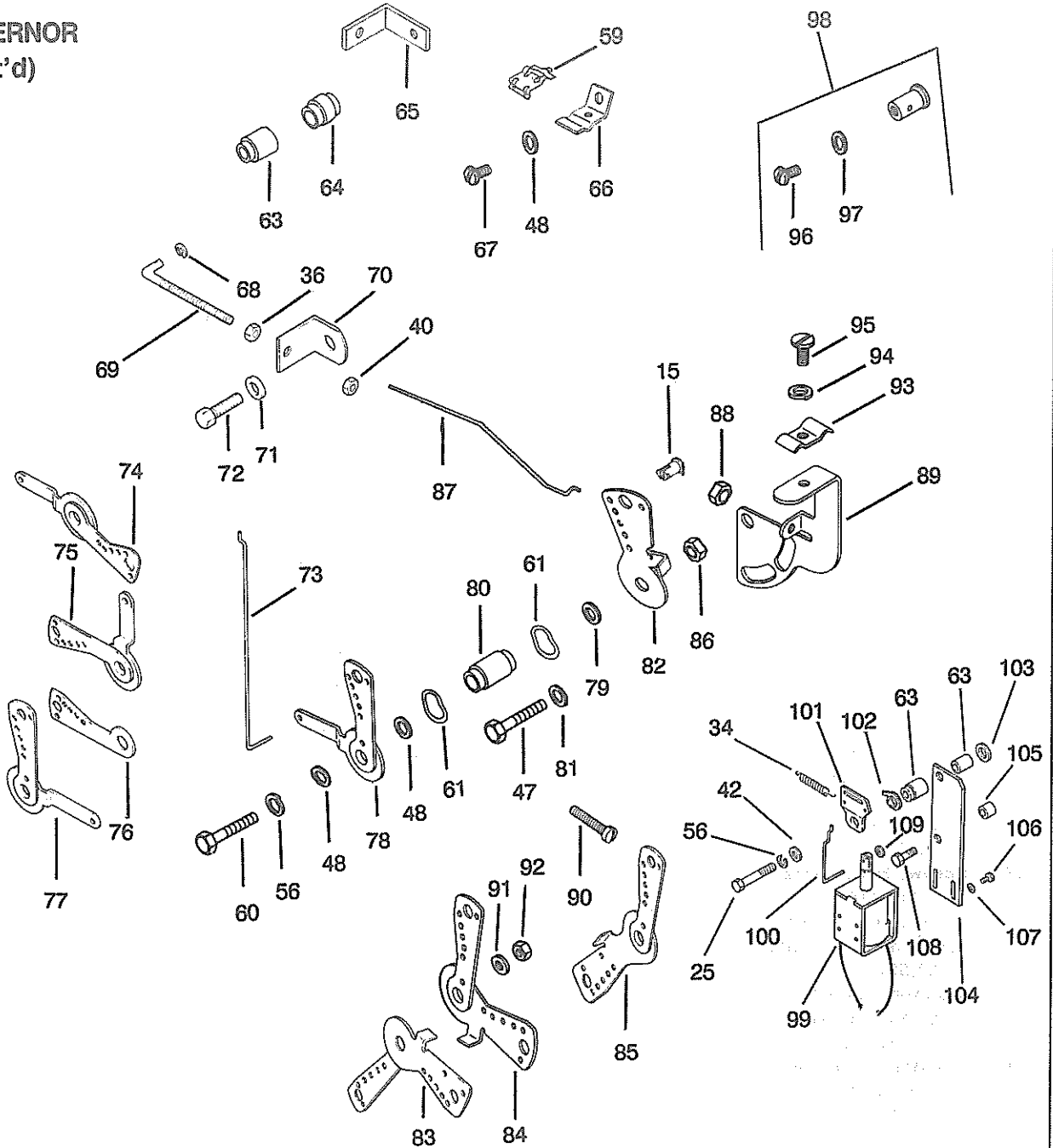

Index Number	Description Variation Number	Part Number	Index Number	Description Variation Number	Part Number
63	Spacer (2) 68,119,149	45 112 01	66	Bracket, throttle cable (Includes 59) 68,98,119,149,153	A-237559
63	Spacer 98,153	45 112 01	67	Screw, H.C. sems 1/4 - 20 x 1/2" 68,81,95,96,97,98,100,104,107, 114,120,140,149,153	X-132-6
63	Spacer 23/64" O.D., 9/16" lg. 81,95,96,104,112,123	235085*	68	Retainer, rod 68,98,119,149,153	235278
64	Spacer 17/64" I.D., 13/32" O.D., 1/2" lg. 81,95,96,104,112	X-384-2*	69	Rod, throttle 68,98,119,149,153	235277
65	Bracket, adjusting screw 123	235084			

Index Number	Description Variation Number	Part Number	Index Number	Description Variation Number	Part Number	
70	Bracket 68,98,119,149,153	47 126 32	91	Washer, plain 9/32 x 5/8 x 3/16" 96	X-25-95	
71	Spacer 9/32" I.D., 3/8" O.D., 7/64" lg. 68,98,119,149,153	25 431 01	92	Nut, hex 1/4-20 96,114	X-81-1	
72	Screw, hex. hd. 1/4-20 x 1/2" 68,98,119,149,153	25 086 14	93	Clamp 81,95,97,100,104,107,112, 114,120,140	47 237 02	
73	Linkage, choke (Carburetor to lever assembly) 81,95,96,100,104,107,112,114, 120,140	47 079 01	94	Washer, lock #10 81,95,97,100,104,107,112, 114,120,140	25 468 04	
74	Lever, choke control 81,104	47 090 07	95	Screw, hex. hd. 10-24 x 3/4" 81,95,97,100,104,107,112, 114,120,140	X-67-51	
75	Lever, choke control 95,120	47 090 40	96	Screw, sltd. pan hd. 8-32 x 1/4" 81,95,96,97,100,104,112, 114,123	X-51-8*	
76	Lever, choke control 96	47 090 05	96	Screw, sltd. pan hd. 8-32 x 1/4" (2) 120	X-51-8	
77	Lever, choke control 114	47 090 50	97	Washer, plain 1/4" 81,95,96,97,100,104,112, 114,123,140	X-25-102*	
78	Lever, choke control 100,107,112,140	47 090 06	97	Washer plain 1/4" (2) 120	X-25-102	
79	Washer, plain 3/8" 96	X-25-82	98	Kit, clamp (Includes 96,97) 81,95,96,97,100,104,112, 114,123,140	48 755 10*	
80	Spacer 23/64" O.D., 13/16" lg. 81,95,100,104,120	47 112 02	99	Solenoid, idle 149	47 435 02	
80	Spacer 23/64" O.D., 31/64" lg. 96,97,107,112,114,140	47 112 19	100	Linkage, solenoid 149	47 079 17	
81	Washer, plain 1/4" 81,95,96,97,100,104,107, 112,120,140	X-25-72	101	Lever, speed control 149	47 090 55	
82	Lever, throttle control 100	47 090 10	102	Stop, governor 149	234614	
82	Lever, throttle control 107,112,140	47 090 25	103	Washer, plain 17/64 x 3/4 x 1/8" 149	X-25-78	
83	Lever, throttle control 96	47 090 09	104	Bracket, solenoid 149	47 126 44	
84	Lever, throttle control 81,97,104	47 090 08	105	Spacer (2) 149	52 112 13	
84	Lever, throttle control 114	47 090 51	106	Screw, hex hd. #8-32 x 1/4" (2) 149	41 086 20	
85	Lever, throttle control 95,120	47 090 39	107	Washer (2) 149	25 468 02	
86	Nut, hex. 1/4-20 81,95,97,100,104,107,112, 120,140	X-76-2	108	Screw, sems 1/4-20 x 1" 149	X-132-4	
87	Linkage, throttle (Swivel clamp to throttle control lever) 81,95,96,104,112	47 079 08	109	Retainer, shaft 149	41 018 03	
88	Nut, hex. 8-32 81,95,96,97,100,104,107,112, 114,120,140	X-72-4	NOT ILLUSTRATED			
89	Bracket, choke 81,95,97,100,104,107,112, 114,120,140	47 126 09	Kit, speed control and choke bracket (Includes 36,48,56,59-63,66-72) 68,98,119,149,153			47 755 34
89	Bracket, choke 96	47 126 13	Bracket, control assembly (Includes 48,60-63,65,96-98) 123			A-236895
90	Screw 8-32 x 5/16" 81,95,96,97,100,104,107,112, 114,120,140	232556	*Note: For variation 104 use before SN 1614100013 only.			

# M12

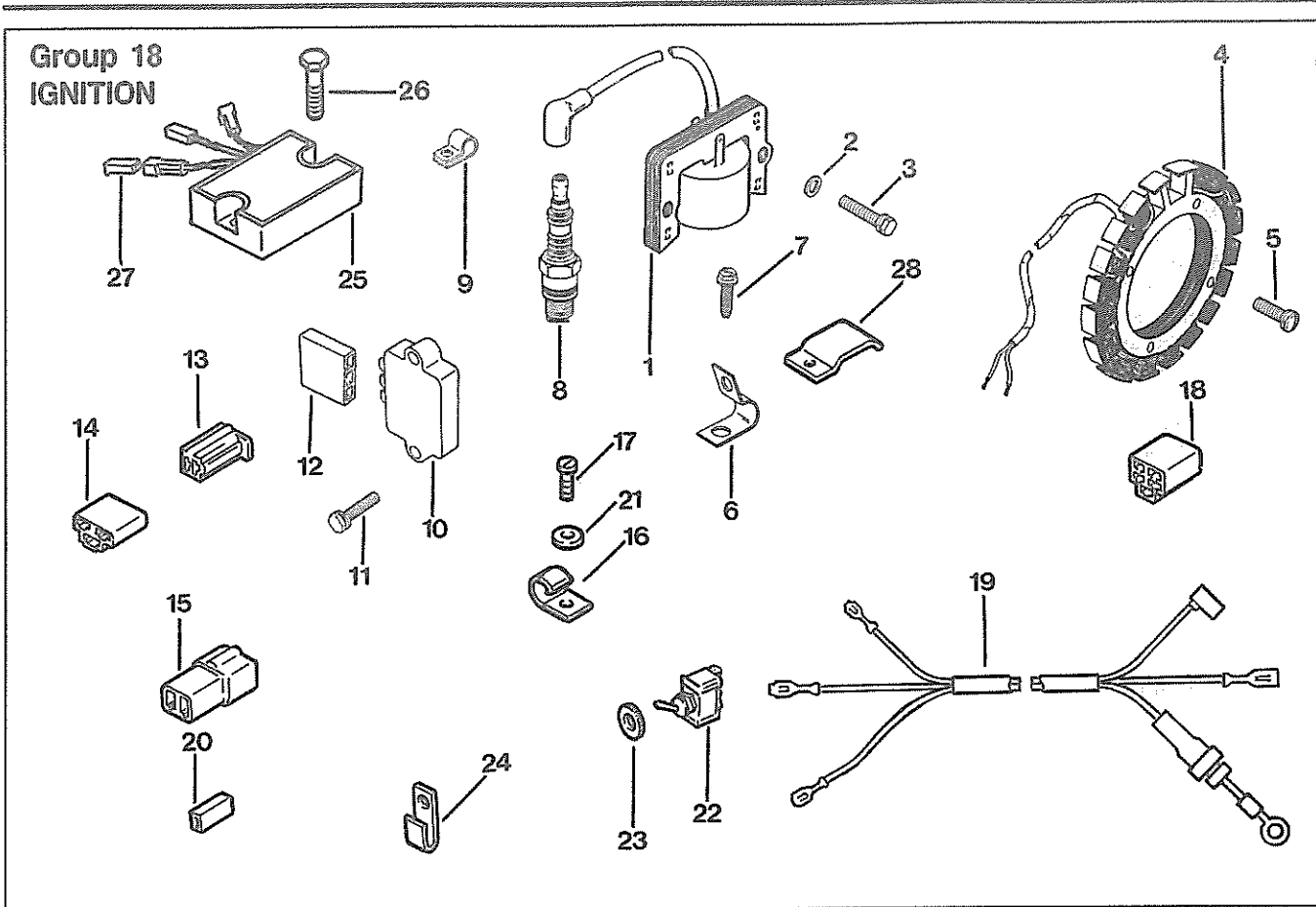

Index Number	Description Variation Number	Part Number	Index Number	Description Variation Number	Part Number
1	Module, Ignition (Replaced by 47 584 02) 236,237,255,259,261,264,267, 269,272,273,280,282,286,300	47 584 01	7	Screw, hex. wash. hd. 8-32 x 3/8" 236,246,255,259,261,264,267, 271,282,286,294,300	X-67-59
1	Module, Ignition w/diode 246,271,294	47 584 02	8	Spark plug RH-10 236,237,246,255,259,261,264, 267,269,271,272,273,280,282, 286,300	235041-S
2	Washer, plain #10 (2) 236,237,246,255,259,261,264,267, 269,271,272,273,280,282,286,294, 300	X-25-79	8	Spark plug 294	25 132 02
3	Screw, H.C. sems 10-24 x 7/8" (2) 236,237,246,255,259,261,264, 267,269,271,272,273,280,282, 286,294,300	X-156-1	9	Clip, hi-tension lead 236,237,246,255,259,261,264, 267,269,271,272,273,280,282, 286,294,300	210281
4	Kit, stator (15 amp.) (Includes 5) 236,246,255,259,261,264,267, 282,286,294,300	237878	10	Rectifier-regulator (Replaced by 25 755 03 kit) 236,255,259,261,264,267,282, 286,300	41 403 05
4	Kit, stator (25 amp.) (Includes 5,27) 271	25 755 07	10	Kit rectifier-regulator, w/screws (Rectifier-regulator marked 41 403 09) 236,246,255,259,261,264,267, 282,286,294,300	25 755 03
5	Screw, pan hd. sems 10-24 x 3/4" (4) 236,246,255,259,261,264,267, 282,286,294,300	X-67-51	11	Screw, H.C. sems 1/4-20 x 1" (2) (Use with 41 403 05) 236,255,259,261,264,267,282, 286,300	X-132-4
5	Screw, pan hd. mach. 10-24 271	25 086 29	11	Screw, H.C. sems 1/4-20 x 5/8" (Use with 41 403 09) 236,246,255,259,261,264,267, 282,286,294,300	X-132-5
6	Clip, lead 236,246,255,259,261,264,267, 282,286,294,300	X-728-1			

Index Number	Description Variation Number	Part Number	Index Number	Description Variation Number	Part Number
12	Connector, female (3 contact) 236,246,255,259,261,264,267, 282,286,294,300	236602		Lead, violet, rectifier-regulator to connector (19" - 14 gauge - un-insulated locking tang female 1/4" terminals)	
13	Connector, male (2 contact) 255,259,261,267,282,286,294	41 155 03		267	41 518 29
14	Connector, female (3 contact) 246,300	236473		Lead, white, w/diode, module to connector (15" - 18 gauge - insulated push on tab - un-insulated push on tab terminals) (Repair w/47 518 43)	
15	Connector, female (2 contact) 261	52 155 04		246,259,261,264,280,286,300	47 518 44
16	Clip, stator leads 255,259,264,267,269,280,282, 286,294	235173		Lead, white, w/diode (Repair lead for leads w/diodes) (5" - 18 gauge - insulated push on tab - Insulink)	
16	Clip, stator leads 264	48 154 01		246,255,259,261,264,267,269, 280,282,286,300	47 518 43
17	Screw, H.C. 1/4-20 x 1/2"	X-132-6		Lead, violet, rectifier-regulator to connector (15" - 14 gauge - un-insulated locking tang female 1/4" terminals)	
17	Screw, hex. wash. hd. 1/4-20 x 7/16"	X-67-83		300	47 518 27
18	Connector, female (5 contact) 282	48 155 01		Lead, violet, rectifier-regulator to connector (23" - 14 gauge - un-insulated locking tang female 1/4" terminals)	
19	Harness, wiring, w/o diode (Use with module w/diode) 282	47 176 08		259,264,286,300	47 518 36
20	Connector, female (1 contact) 269,280	277563		Lead, white, w/diode, module to switch (10" - 18 gauge - insulated push on tab, insulated grip barrel eyelet terminals)	
21	Washer, plain 17/64 x 9/16 x 1/16"	X-25-72		272,273	25 518 16
22	Switch, DPST, 4 terminals 272	238011		Lead, white, ground to switch (12" - 18 gauge - insulated grip barrel eyelet terminals)	
22	Switch, SPST, 2 terminals 272	151510		272,273	25 518 17
22	Switch, SPDT, 3 terminals 273	25 099 07		Lead, red, connector to cam cover screw (4" - 18 gauge - un-insulated male bullet, insulated grip barrel eyelet terminals)	
23	Nut, knurl 272	41 100 06		272,273	47 518 51
24	Clip-on fuel pump screw 272,273	275303		Lead, red, toggle switch to connector (14" - 18 gauge un-insulated male bullet, insulated grip barrel eyelet terminals)	
25	Rectifier-regulator, 25 amp 271	25 403 01		272,273	47 518 50
26	Screw, H.C. sems 1/4-20 x 5/8"	X-132-5		Lead, light blue, solenoid to switch (23" - 18 gauge - insulated grip barrel eyelet insulated push-on female flag 1/4" terminals)	
27	Connector, receptacle 271	25 155 04		273	25 518 19
28	Clip 271	234531		Lead, red, solenoid terminal to solenoid tab (3" - 18 gauge - insulated grip barrel eyelet, insulated push-on female 1/4" terminals)	
NOT ILLUSTRATED				273	25 518 20
	Lead, violet, rectifier-regulator to connector (12-1/2" - 14 gauge - un-insulated locking tang female 1/4" terminals) 246,255,261,282,294,300	47 518 46		Lead, white, w/diode, module to switch (10" - 18 gauge insulated push-on tab, insulated grip barrel eyelet terminals) (Replaced by 25 518 16)	
	Lead, violet, rectifier-regulator to connector (11" gauge - un-insulated locking tang female 1/4" terminals) 282,300	47 518 33		273	25 518 18
	Lead, white, w/diode, module to connector (23" - 18 gauge - insulated push on tab - un-insulated push on tab terminals) (Repair w/47 518 43) 255,267,269,294	47 518 45			

Group 19  
INSTRUMENT PANEL

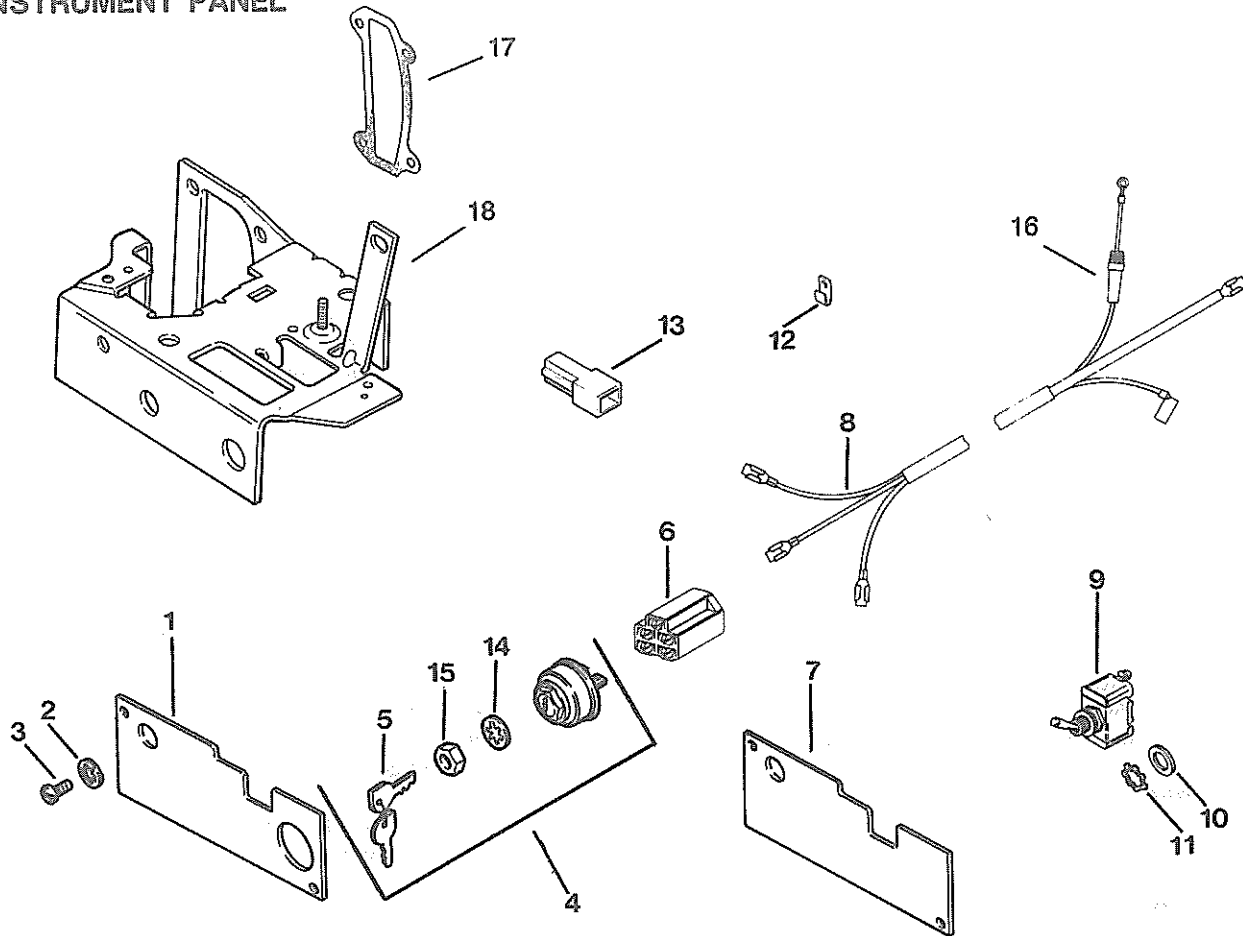

Index Number	Description Variation Number	Part Number	Index Number	Description Variation Number	Part Number
1	Panel, Instrument 43,49,53,54,63,68	47 378 06	4	Switch, key assembly (Includes 5, 14, 15) 43,51,53,54,60,63,68,74,90,92, 300,301,302	25 099 04
1	Panel, Instrument 60	47 378 08	5	Key (Set of 2) 43,51,53,54,60,63,68,74,90,92, 300,301,302	48 340 01
1	Panel, Instrument (Use before serial no. 2119100013) 304	47 378 05	6	Connector 43,51,53,54,60,63,68,74,90,92	48 155 01
1	Panel, instrument (Use before serial no. 2119100013) 303	47 378 06	7	Panel, instrument 44,51,71,302	47 378 05
1	Panel, instrument 90	47 378 09	8	Harness, wiring w/diode (Replace diode w/service component) (Use before Serial No. 1725100013) (47 518 43 lead w/diode) (Replaced by 47 175 08) 43,53,54	47 176 05
2	Washer, I.T. #10 (2) 43,44,49,51,53,54,63,68,71,302	X-22-9	8	Harness, wiring w/o diode (Use with module w/diode) (Use after Serial No. 1725100009) 43,53,54	47 176 08
3	Screw, sltd. pan hd. 10-24 x 3/8" (2) 43,44	X-131-1			
3	Screw, H.C. sems 1/4-20 x 1/2" (2) 60	X-132-6			
3	Screw, sltd. pan hd. 10-24 x 3/8" (2) (Use before serial no. 2119100013) 303,304	X-131-1			



Index Number	Description Variation Number	Part Number	Index Number	Description Variation Number	Part Number
8	Harness, wiring 60	47 176 11		Lead, red B+ to solenoid lead (22" - 12 gauge - uninsulated push-on locking tang male 1/4", insulated grip barrel eyelet terminals)	
8	Harness, wiring, w/oil sentry lead 63,68	47 176 12		68	47 518 35
8	Harness, wiring 71	47 176 06		Lead, green ground to switch (3" - 18 gauge - insulated grip barrel eyelet terminals)	
8	Harness, wiring w/o diode 74	47 176 08		49, 81	47 518 39
8	Harness, wiring 93	47 176 17		Lead, white, w/diode (Service replacement lead for wiring lead w/diode) (5" - 18 gauge - insulated push on tab-insulink)	47 518 43
8	Harness, wiring 92	47 176 16		Lead, violet, reg/rect (23" - 14 gauge - uninsulated locking tang female 1/4" terminals)	
9	Switch, SPST, 2 terminals 49, 81	151510		90	47 518 36
10	Washer, plain 7/16" 49, 81	X-25-34		Lead, light blue (6" - 18 gauge - uninsulated push on tab- insulated push on tab terminals)	
11	Washer internal/external tooth 1/2" 49, 81	X-22-26		90	47 518 20
12	Clip, on fuel pump screw 60	275303		Decal, panel w/keyswitch hole 43,44,54,63,68,90	47 113 10
13	Connector, tab (2) 68	25 155 03		Decal, panel w/o keyswitch hole 43,44,71,302	47 113 11
14	Washer 43,51,53,54,60,63,68,74,90,92, 300,301,302	48 468 02		Decal, panel w/o keyswitch hole (Use before serial no. 2119100013)	
15	Nut 43,51,53,54,60,63,68,74,90,92, 300,301,302	48 100 01		304	47 113 11
16	Holder, fuse (Includes 41 304 01 fuse) 90	25 323 01		Decal, panel w/toggle switch hole 49	47 113 17
17	Gasket, cam cover (Use after serial no. 2119100003) 303,304	235025		Decal, panel w/o keyswitch hole 51	47 113 15
17	Gasket, cam cover 73,74,92,93, 81	235025		Decal, panel w/keyswitch hole (Discontinued not available at Kohler Co.) 53	47 113 14
18	Bracket, control panel (Use after serial no. 2119100003) 303,304	47 126 43		Decal, panel w/keyswitch hole (Discontinued not available at Kohler Co.) (Use before serial no. 2119100013)	
18	Bracket, control panel 73,74,92,93, 81	47 126 43		303	47 113 14
<b>NOT ILLUSTRATED</b>				Decal, panel w/keyswitch and oil sentry holes 60,90	41 113 12
	Fuse 90	41 304 01		Decal, control panel (Use after serial no. 2119100003) 303	47 113 27
	Lead, violet, keyswitch to rectifier-regulator (11" - 14 gauge - uninsulated push on tab terminals) 43,53,63,74,92	47 518 33		Decal, panel 73,93	47 113 25
	Lead, white, module to kill switch (19" - 18 gauge - insulated push on tab terminals) 44,73,302,304	47 518 42		Decal, panel 74,92	47 113 24
	Lead, black, module to switch (21" - 18 gauge - insulated grip barrel eyelet, insulated push-on female 3/16" terminals) 49	47 518 47		Decal, control panel (Use after serial no. 2119100013) 304	47 113 25

# M12

## Group 21 OIL PAN

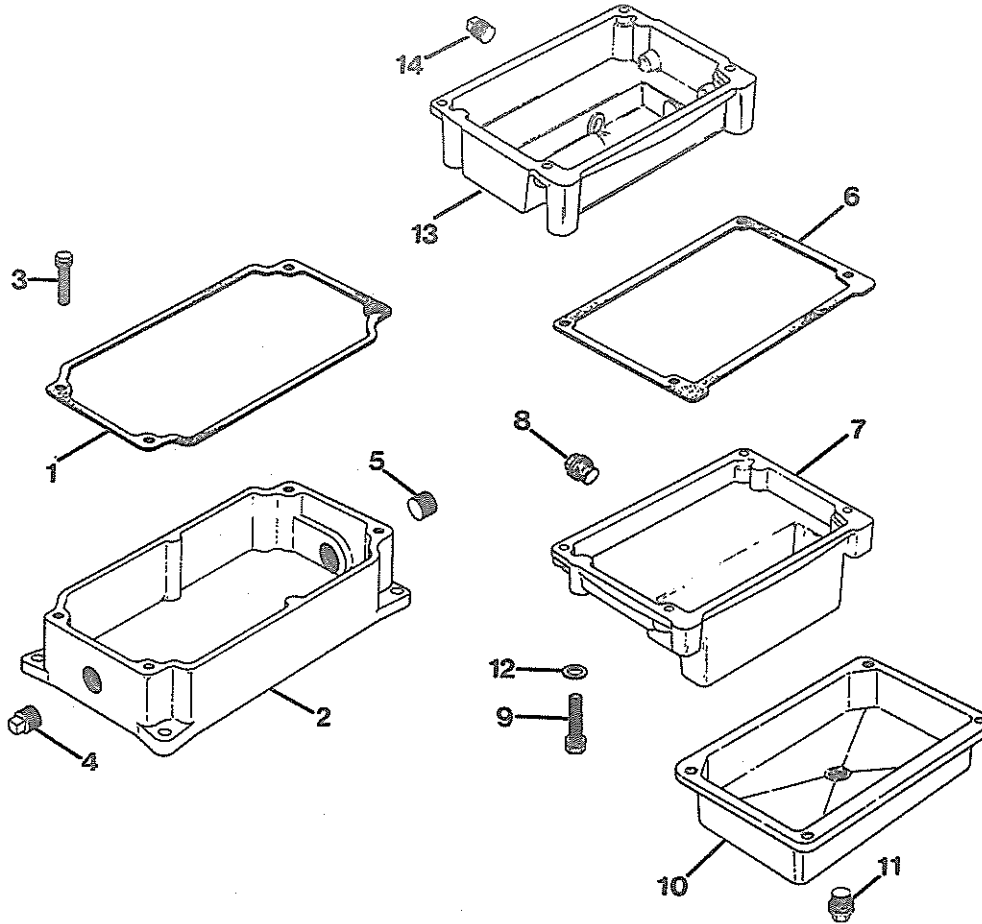

Index Number	Description Variation Number	Part Number	Index Number	Description Variation Number	Part Number
1	Gasket, oil pan 1,23,57,58,59,63,624,854,856, 656	235057	6	Gasket, oil pan 54	47 041 07
2	Pan, oil (side drain) 1	235115	7	Pan, oil (side drain) 36	47 199 09
2	Pan, oil (side drain) 23	237763	8	Plug, drain w/fiber gasket 3/8-18" N.P.T.F. 36	X-708-1
2	Pan, oil (double drain) 58,59	47 199 15	9	Screw, H.C. sems 3/8-16 x 1-1/2" (4) 36,67	X-159-4
2	Pan, oil (drain on starter side) 63,624	45 199 05	9	Screw, H.C. sems 3/8-16 x 1" (4) 54	X-159-2
2	Pan, oil (double drain) 854,856, 656	47 199 10	10	Pan, oil (bottom drain) 54	47 199 07
2	Pan, oil (bottom drain) 57	235147	11	Plug, pipe hex. hd. 3/8" 54	X-75-32
3	Screw, H.C. sems 3/8-16 x 1-1/4" (4) 1,23,57,58,59,63,624,854,856, 656	X-159-3	11	Plug, magnetic drain hex hd. 3/8" 57	X-305-4
4	Plug, sq. hd. solid 3/4" N.P.T.F. 1,58,59,854,856	X-75-6	12	Washer, plain 3/8" 54,56, 656	X-25-37
4	Plug, sq. hd. 3/8" 23,63,624	X-75-10	13	Pan, oil (bottom and side drain) 67	47 199 16
5	Plug, sq. ctsk. 1/2" N.P.T.F. 58,63	X-75-3	14	Plug, pipe ctsk. hd. 1/4" 67	X-75-38
5	Plug, sq. hd. solid 3/4" N.P.T.F. 854	X-75-6			
6	Gasket, oil pan 36,67	235353			

# M12

## Group 22 PISTON & ROD

Old Style Piston  
and Rod

New Style Mahle Piston  
and Rod

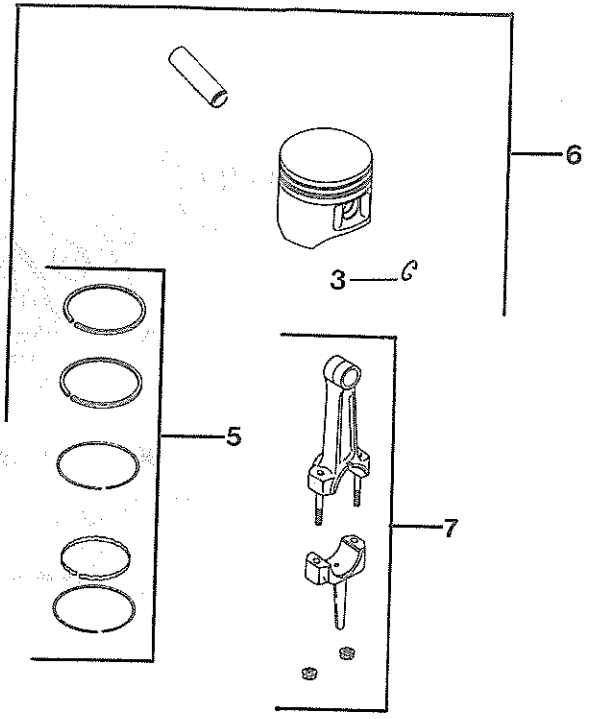
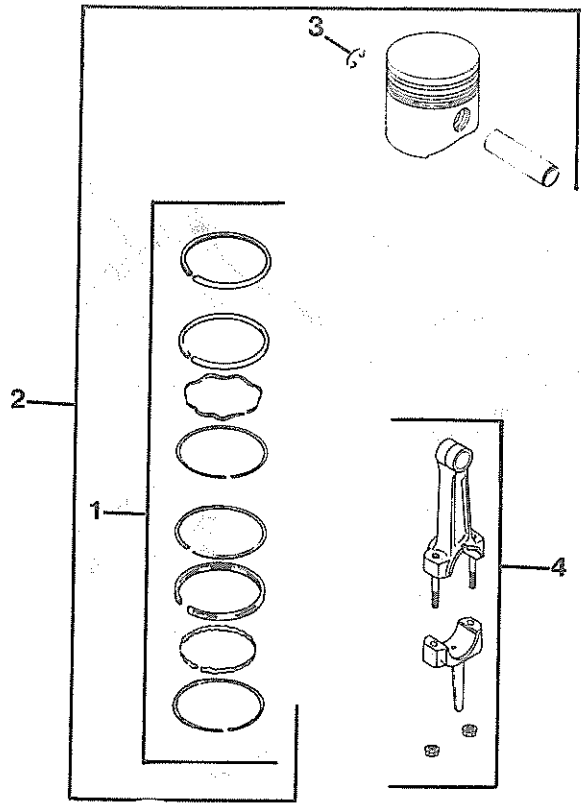

Index Number	Description Variation Number	Part Number	Index Number	Description Variation Number	Part Number
<b>OLD STYLE PISTON DESIGN:</b>			<b>NEW STYLE MAHLE PISTON DESIGN:</b>		
1	Ring set (Std. & .003) (Replaced by 48 108 01) 17	235889	5	Ring set (Std. & .003) 17	47 108 01
	Ring set (.010) (Replaced by 48 108 02)	235890		Ring set (.010)	47 108 02
	Ring set (.020) (Replaced by 48 108 03)	235891		Ring set (.020)	47 108 03
	Ring set (.030) (Replaced by 48 108 04)	235892		Ring set (.030)	47 108 04
2	Piston w/ring set (Std.) 17	47 874 06	6	Piston w/ring set (Std.) 17	47 874 16
	Piston w/ring set (.030)	47 874 07		Piston w/ring set (.003)	47 874 17
	Piston w/ring set (.010)	47 874 08		Piston w/ring set (.010)	47 874 18
	Piston w/ring set (.020)	47 874 09		Piston w/ring set (.020)	47 874 19
	Piston w/ring set (.030)	47 874 10		Piston w/ring set (.030)	47 874 20
3	Retainer, piston pin (2) 17	47 018 01	7	Connecting rod (Std.) 17	45 067 24
4	Connecting rod (Std.) 17	47 067 09		Connecting rod (.010)	45 067 25
	Connecting rod (.010)	47 067 10			

NOTE: ORDER PARTS ACCORDING TO DESIGN USED ON ENGINE.

# M12

## Group 23 RETRACTABLE STARTER

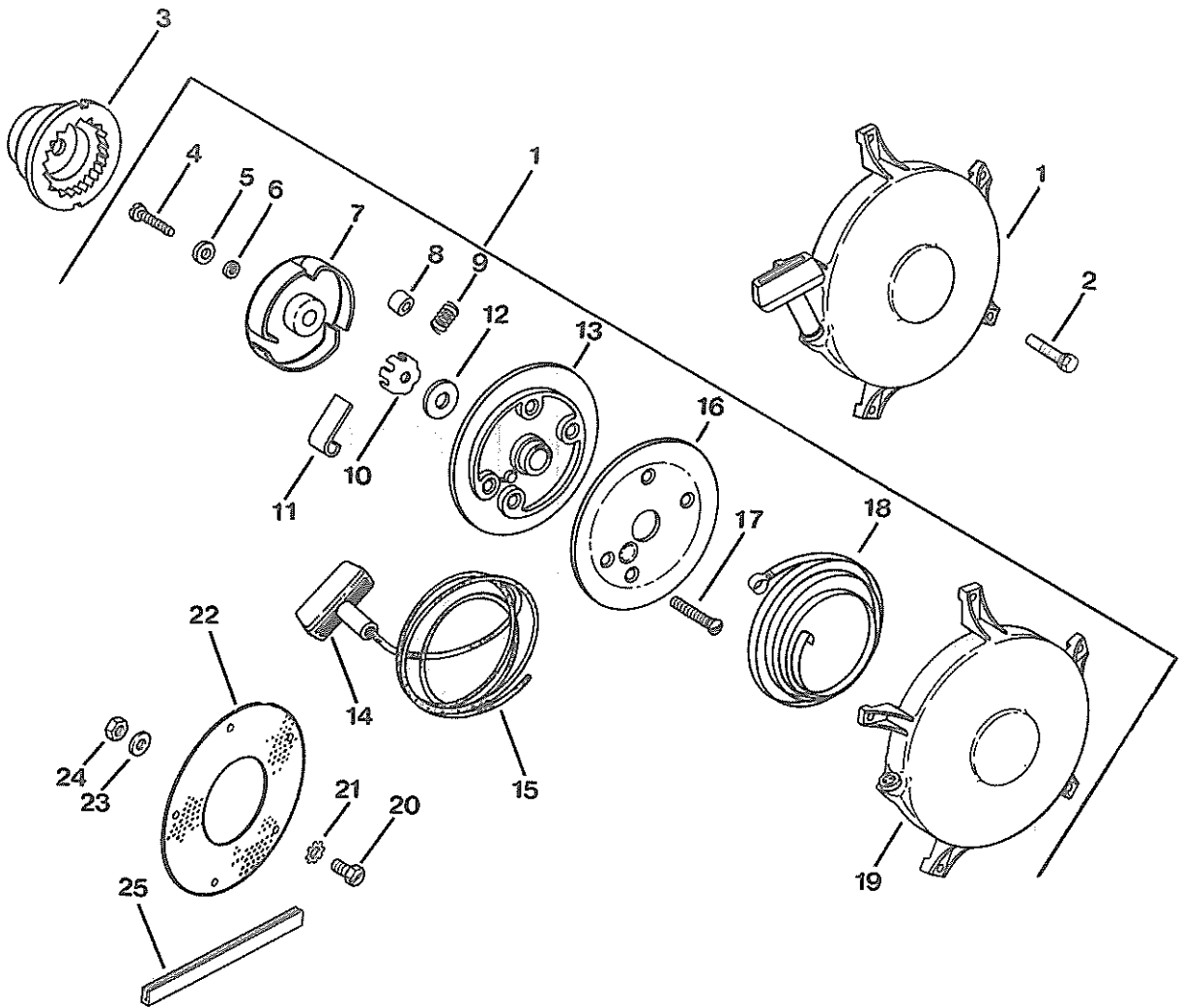

Index Number	Description Variation Number	Part Number	Index Number	Description Variation Number	Part Number
1	Starter, retractable assembly (Includes 4-19) 8,11	47 165 01	8	Spacer, nylon 8,11,12	47 112 04
1	Starter, retractable assembly w/grass screen (Includes 4-25) 12	A-237251	9	Spring, retainer (Use with spacer) 8,11,12	232525
2	Screw, H.C. sems 10-24 x 5/8" (5) 8,11,12	X-156-2	9	Spring, dog (3) (Replaces (1) spring 232525 and (1) spacer 47 112 04) 8,11,12	41 089 06
3	Cup, drive 8,11,12	47 109 01	10	Brake 8,11,12	231689
4	Screw, hex. hd. 10-32 x 5/8" 8,11,12	231691	11	Dog (3) 8,11,12	231695
5	Washer 8,11,12	231690	12	Washer, thrust 8,11,12	231692
6	Washer 8,11,12	231693	13	Pulley 8,11,12	231697
7	Retainer 8,11,12	231699	14	Handle 8,11,12	234452

RETRACTABLE STARTER  
(Cont'd)

M12

Index Number	Description Variation Number	Part Number	Index Number	Description Variation Number	Part Number
15	Rope, #6 (66" long) 8,11,12	231686	21	Washer, ext tooth #10 (5) 12	X-22-22
16	Sheave 8,11,12	231685	22	Screen, grass 12	237250
17	Screw (4) 8,11,12	231683	23	Washer, plain 7/32" (5) 12	X-25-36
18	Spring, recoll 8,11,12	231705	24	Nut, hex. 10-32" (5) 12	X-70-3
19	Housing 8,11,12	235696	25	Channel, rubber 3/8 x 10" 12	X-532-2
20	Screw, slotted hex. hd. #10-1/2" (5) 12	X-97-2			

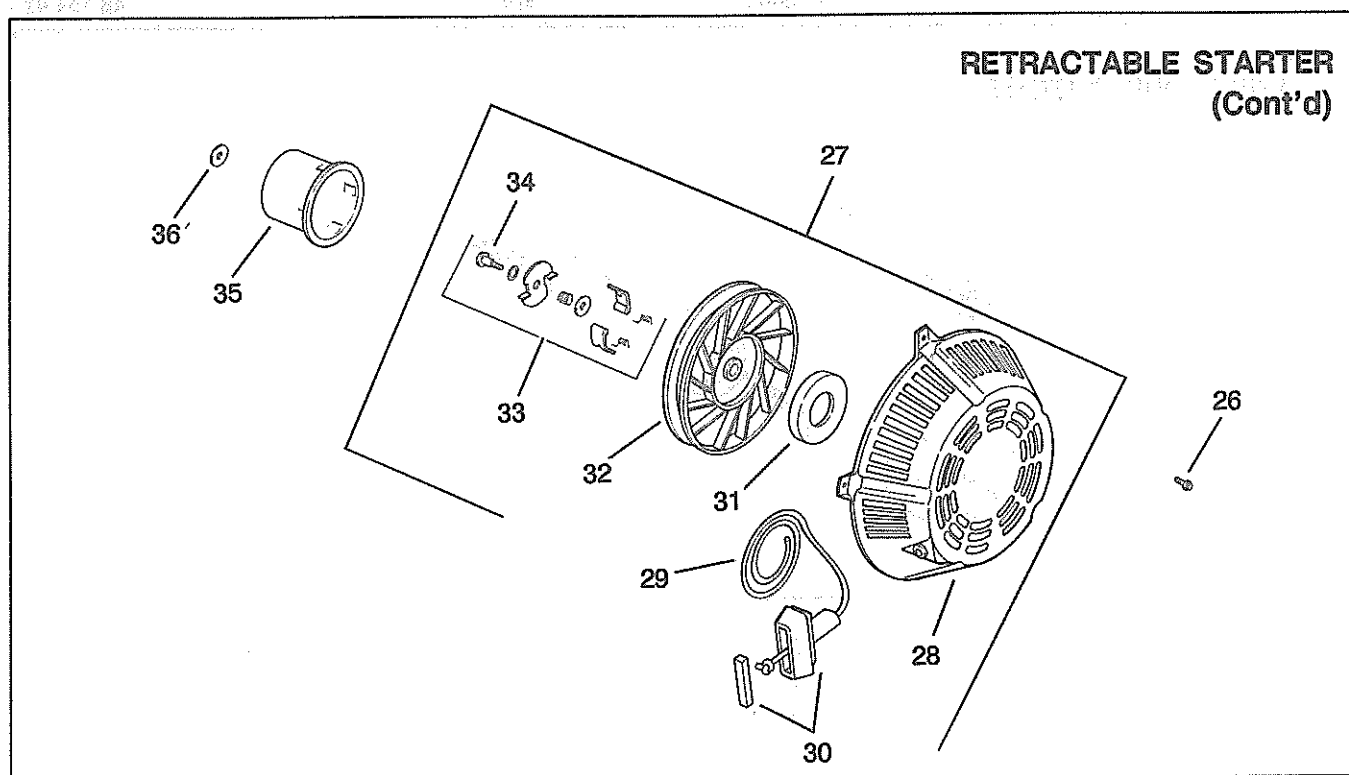

Index Number	Description Variation Number	Part Number	Index Number	Description Variation Number	Part Number
26	Screw, flange lock 10-24 x 1/4" (5) 13	41 086 06	32	Pulley 13	12 093 01
27	Starter, retractable assembly (Includes 28-34) 13	12 165 01	33	Kit, pawl (dog) repair (Includes 34) 13	12 757 06
28	Housing 13	12 081 01	34	Screw, pozidriv 13	41 086 09
29	Rope 13	12 160 01	35	Cup, drive 13	15 109 01
30	Handle, recoll starter 13	234452	36	Washer, flat 13	47 468 09
31	Spring, keeper 13	12 089 06			

Group 24  
Group 32

M12

**Group 24  
THROTTLE CABLE**

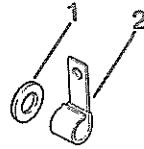

Index Number	Description Variation Number	Part Number	Index Number	Description Variation Number	Part Number
1	Washer, plain 17/64 x 9/16 x 1/16" 826	X-25-72	2	Clip, throttle cable 826	48 154 01

**Group 32  
OIL PRESSURE CUTOUT**

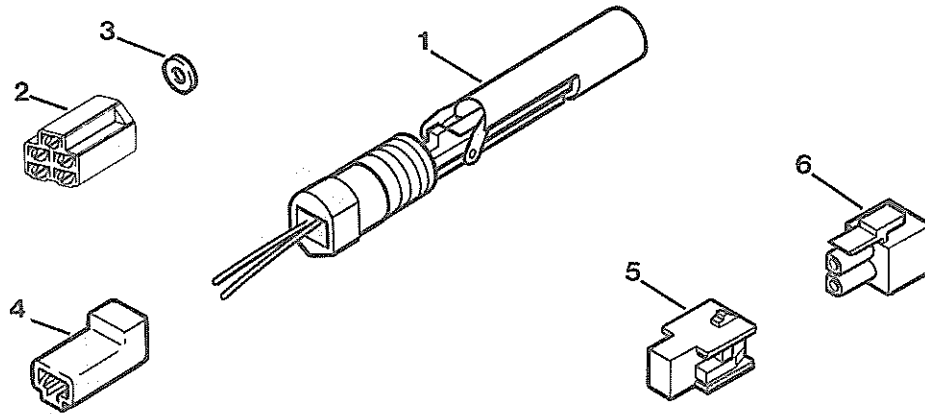

Index Number	Description Variation Number	Part Number	Index Number	Description Variation Number	Part Number
1	Kit, oil pressure switch (Includes decal 25 113 05, terminals 25 452 03, 25 452 07, sleeving 25 431 02) (Replaced by 25 704 03) 2,4,5,9	25 704 01	6	Connector, oil sentry 9	47 155 14
1	Kit, oil pressure switch (Includes decal 25 113 05, terminals 25 452 01, 25 452 02, 25 452 03, sleeving 25 431 03) 3	25 704 04	<b>NOT ILLUSTRATED</b>		
2	Connector 3	48 155 01		Decal, oil sentry 2,3,4,5,9	25 113 05
3	Washer, plain 17/64 x 1/2 x 1/16" (On ground screw) 5	X-25-63		Terminal (2) (Uninsulated locking tongue, female push on tab 1/4") 3	25 452 01
4	Connector (Use before serial no.1922900013) 5	277563		Terminal (Ring tongue insulated grip) 3	25 452 02
5	Connector, ground and toggle switch leads 9	47 155 13		Terminal (Ring tongue insulated grip) 2,3,4,5,9	25 452 03
				Terminal (Uninsulated locking tang, female push on tab 1/4") 2,4,5,9	25 452 07
				Sleeving 2,4,5,9	25 431 02
				Sleeving 3	25 431 03

## M12

Description Variation Number	Part Number	Description Variation Number	Part Number
GASKET SET (w/seals)	47 755 27	GASKET SET (w/o seals)	47 044 02
Set Includes:		Set Includes:	
Plug, cup	X-702-3	Plug, cup	X-702-3
Seal, breather	231032	Seal, breather	231032
Gasket, camshaft cover (2)	235025	Gasket, camshaft cover (2)	235025
Gasket valve cover	235048	Gasket, valve cover	235048
Gasket, oil pan	235057	Gasket, oil pan	235057
Gasket, exhaust	235122	Gasket, exhaust	235122
Gasket, oil fill tube	237064	Gasket, oil fill tube	237064
Gasket, cylinder head	47 041 15	Gasket, cylinder head	47 041 15
Gasket, valve cover	275144	Gasket, valve cover	275144
Seal, front oil	47 032 06	Gasket, fuel pump	25 041 05
Seal, rear oil	47 032 07	Gasket, air cleaner	47 041 05
Gasket, fuel pump	25 041 05	Gasket, oil pan	47 041 07
Gasket, air cleaner	47 041 05	Gasket, bearing plate	47 041 09
Gasket, oil pan	47 041 07	Gasket, carburetor	47 049 01
Gasket, bearing plate	47 041 09	Gasket, bearing plate (3)	47 422 05
Gasket, carburetor	47 049 01		
Gasket, bearing plate (3)	47 422 05		

**THE NEW SHAPE OF KOHLER POWER**

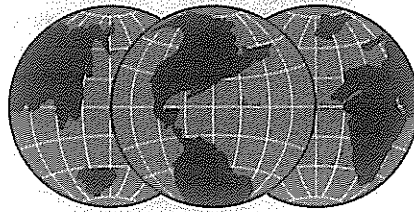

**KOHLER**engines

ENGINE DIVISION, KOHLER CO., KOHLER, WISCONSIN 53044

FOR SALES AND SERVICE INFORMATION  
IN U.S. AND CANADA, CALL  
**1-800-544-2444**

FORM NO.:	TP-2230-D
ISSUED:	3/86
REVISED:	5/92
MAILED:	6/92

LITHO IN U.S.A.