

PARTS MANUAL

MAGNUM

MODEL M8 8HP

Engine Specs-301500 - 301627

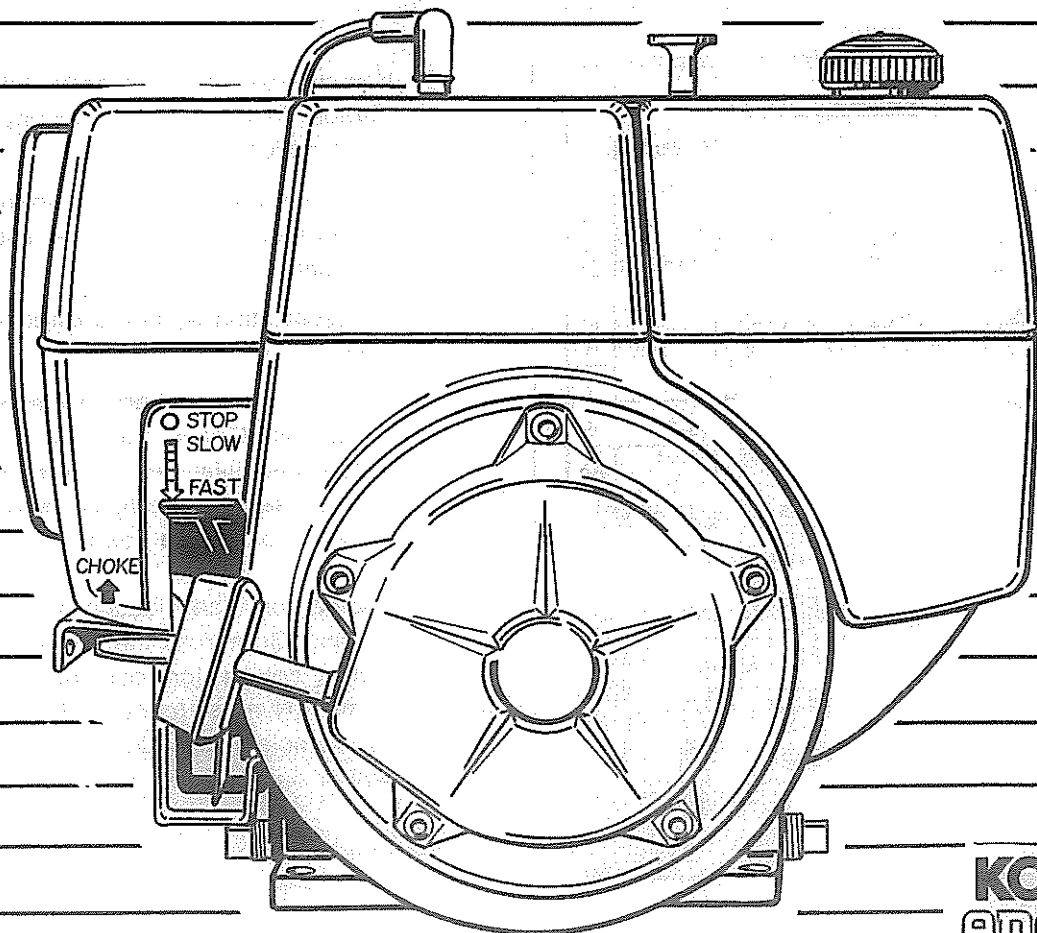

KOHLER
engines

HOW TO FIND PART NUMBERS

MB

**Group 1
AIR INTAKE**

Index Number	Description	Part Number
1	Wing nut (14-20)	X376-7
2	Cover, air cleaner	41 096 29
3	Cover, air cleaner	41 099 38
4	Washer (14-20)	331855
5	Element, prescaler	41 094 16
6	Element, prescaler	41 094 15
7	Washer (14-20)	331855
8	Washer (14-20)	331855
9	Washer (14-20)	331855
10	Washer (14-20)	331855

2 Cover, air cleaner

130, 136, 500
41 096 29

3. Go to the page for your Group (page 8) and look at the illustrations to find the one most similar to the original part.

A. Each part in the illustration is identified with an index number or letter. Use that identifier to locate the part description in the listing.

B. Find your "Variation Number", from Step 2, immediately below the description.

C. The correct part number will be in the column to the right of your variation number.

For our example, the air cleaner cover that looks like the original is index number 2.

Looking in the listing next to index 2, we find our Variation Number (130), is shown, so the correct part number is 41 096 29.

Special Features

Near the end of the Parts Manual Binder is a separate section devoted to repair options for major damage. "Selection Guides" for each model engine give several different methods of repairing Kohler Engines . . . with the choice dependent on shop facilities, costs, and allowable downtime of the engine and/or equipment.

Selection guides are easy references for determining part numbers of Replacement Engines, Short Blocks, or Miniblocks. They also list part numbers of crankshafts installed in original engines.

Here is what you'll find:

A. Engine model is identified on each page for easy reference;

B. Bold column heads identify the various repower options for every engine spec;

C. All crankshaft changes required for Replacement Engines are flagged with "Yes;"

D. Replacement Engines, Short Blocks, or Miniblocks.

MB

There are several methods of repowering MB engines to consider—with the choice depending on your shop facilities, repair costs, and allowable downtime of the engine.

- Engine Replacement:** When decision is to replace, use a Kohler Replacement Engine—No modifications required.
- Short Block Replacement:** When engine including the crankshaft is extensively damaged or worn internally. Refer to page 4 for short block components.
- Miniblock Replacement:** When bore, piston, and connecting rod are damaged but crankshaft and all other parts are in good condition. Refer to page 5 for miniblock components.
- Complete Overhaul:** Refurbish cylinders and grind crankshaft, using appropriate oversize and/or undersize replacement parts.

This Selection Guide provides an easy reference for determining the part number of the Replacement Engine, Short Block, or Miniblock required for the repower method selected. It also lists the part number of the crankshaft installed in the original engine.

Locate the engine specification number in the index below. Select the part number of the repair method listed in the adjacent columns.

ENGINE SPECIFICATIONS					
Eng. No.	Spec. No.	Required Crank- Shaft Changes	Original Engine Crankshaft	Repower. Short Block	Repower. Miniblock
301600*	301500*	--	231767	41 522 50	41 782 09
301601*	301501*	--	231767	41 522 50	41 782 09
301602*	301502*	--	231767	41 522 50	41 782 09
301603*	301503*	--	231767	41 522 50	41 782 09
301604*	301504*	--	231767	41 522 50	41 782 09
301605*	301505*	--	231767	41 522 50	41 782 09
301606*	301506*	--	231767	41 522 50	41 782 09
301607*	301507*	--	231767	41 522 50	41 782 09
301608*	301508*	--	231767	41 522 50	41 782 09
301609*	301509*	--	231767	41 522 50	41 782 09
301610*	301510*	--	231767	41 522 50	41 782 09
301611*	301511*	--	231767	41 522 50	41 782 09
301612*	301512*	--	231767	41 522 50	41 782 09
301613*	301513*	--	231767	41 522 50	41 782 09
301614*	301514*	--	231767	41 522 50	41 782 09
301615*	301515*	--	231767	41 522 50	41 782 09
301616*	301516*	--	231767	41 522 50	41 782 09
301617*	301517*	--	231767	41 522 50	41 782 09
301618*	301518*	--	231767	41 522 50	41 782 09
301619*	301519*	--	231767	41 522 50	41 782 09
301620*	301520*	--	231767	41 522 50	41 782 09
301621*	301521*	--	231767	41 522 50	41 782 09
301622*	301522*	--	231767	41 522 50	41 782 09
301623*	301523*	--	231767	41 522 50	41 782 09
301624*	301524*	--	231767	41 522 50	41 782 09
301625*	301525*	--	231767	41 522 50	41 782 09
301626*	301526*	--	231767	41 522 50	41 782 09
301627*	301527*	--	231767	41 522 50	41 782 09
301628*	301528*	--	231767	41 522 50	41 782 09
301629*	301529*	--	231767	41 522 50	41 782 09
301630*	301530*	--	231767	41 522 50	41 782 09
301631*	301531*	--	231767	41 522 50	41 782 09
301632*	301532*	--	231767	41 522 50	41 782 09
301633*	301533*	--	231767	41 522 50	41 782 09
301634*	301534*	--	231767	41 522 50	41 782 09
301635*	301535*	--	231767	41 522 50	41 782 09
301636*	301536*	--	231767	41 522 50	41 782 09
301637*	301537*	--	231767	41 522 50	41 782 09
301638*	301538*	--	231767	41 522 50	41 782 09
301639*	301539*	--	231767	41 522 50	41 782 09
301640*	301540*	--	231767	41 522 50	41 782 09
301641*	301541*	--	231767	41 522 50	41 782 09
301642*	301542*	--	231767	41 522 50	41 782 09
301643*	301543*	--	231767	41 522 50	41 782 09
301644*	301544*	--	231767	41 522 50	41 782 09
301645*	301545*	--	231767	41 522 50	41 782 09
301646*	301546*	--	231767	41 522 50	41 782 09
301647*	301547*	--	231767	41 522 50	41 782 09
301648*	301548*	--	231767	41 522 50	41 782 09
301649*	301549*	--	231767	41 522 50	41 782 09
301650*	301550*	--	231767	41 522 50	41 782 09

*Basic Engine All Short Blocks and Miniblocks include an overhead gaslet set.

COMPOSITE EXPLODED VIEW

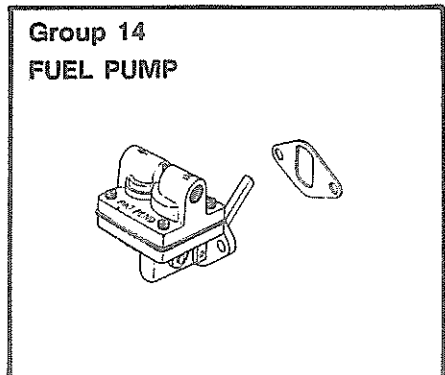
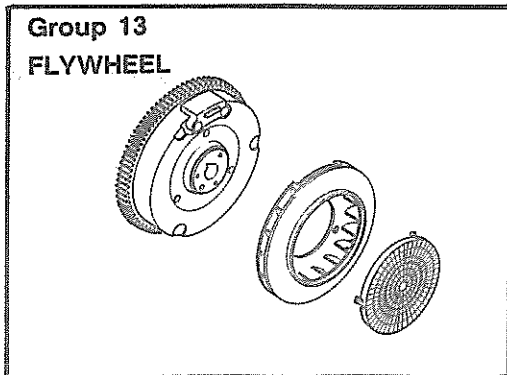
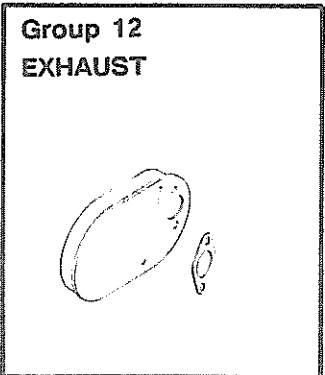
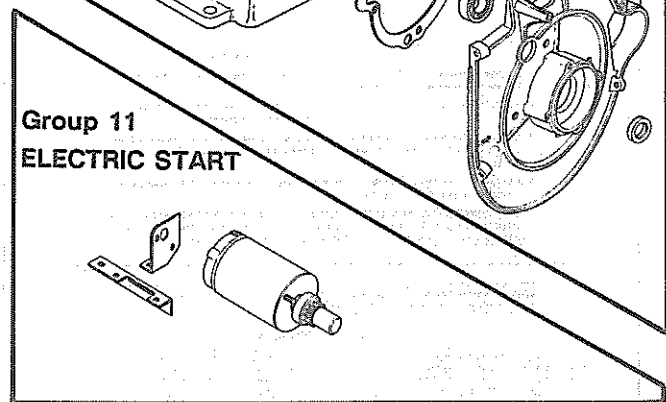
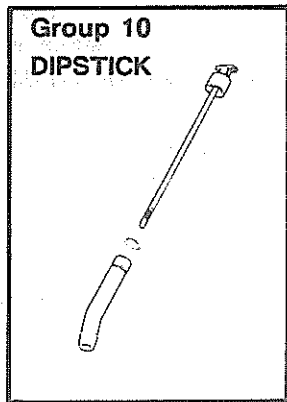
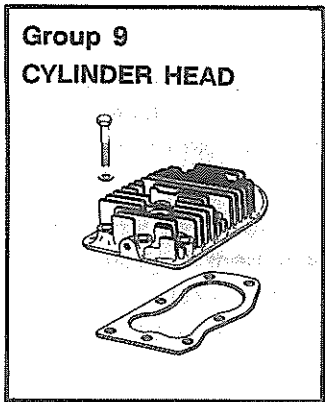
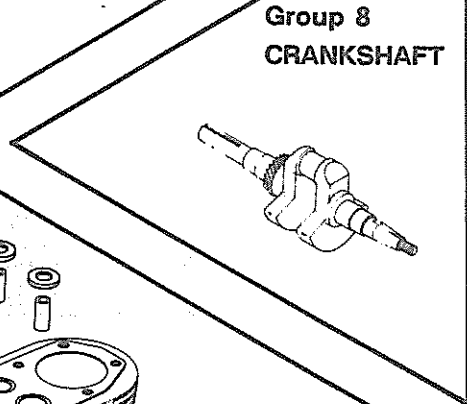
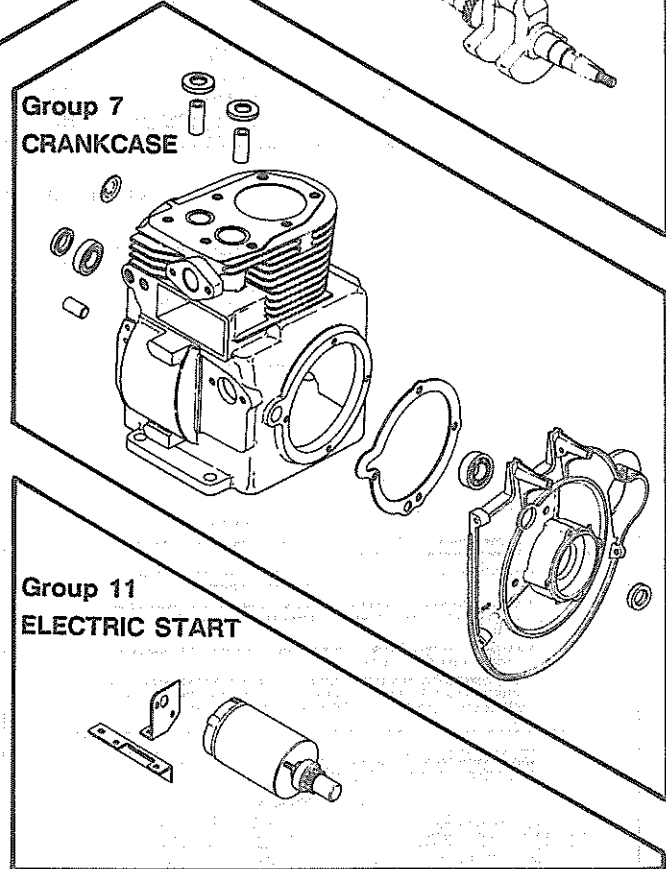
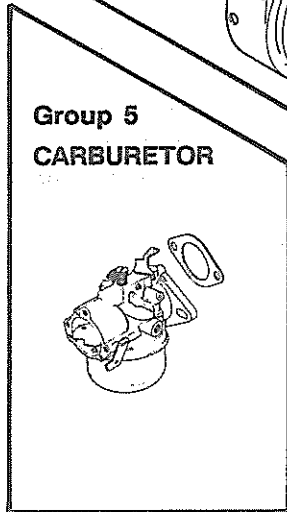
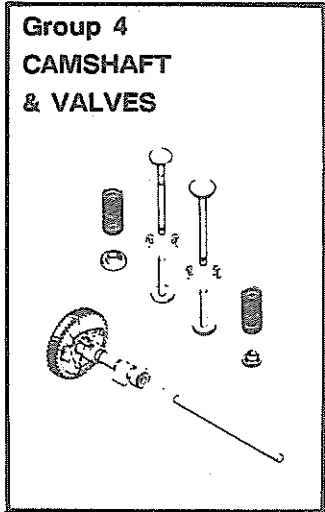
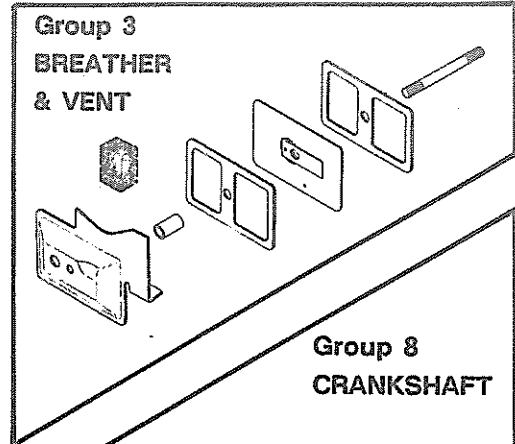
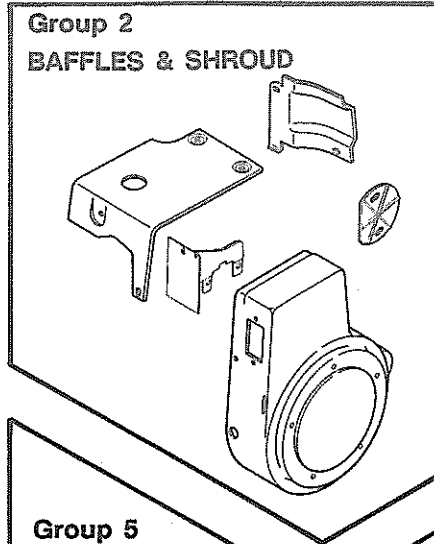
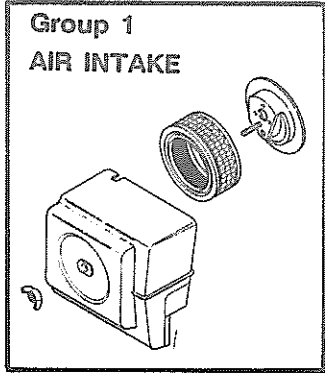

COMPOSITE EXPLODED VIEW

**Group 15
FUEL TANK**

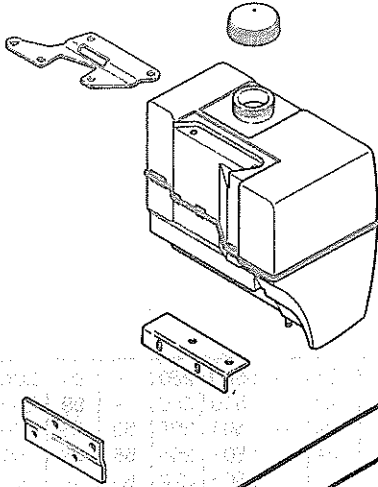

**Group 16
GEAR REDUCTION**

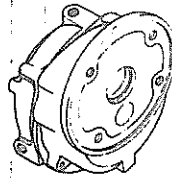

**Group 17
GOVERNOR**

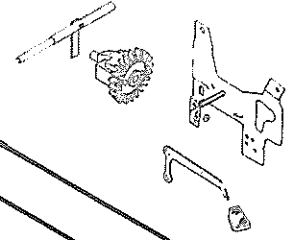

**Group 18
IGNITION**

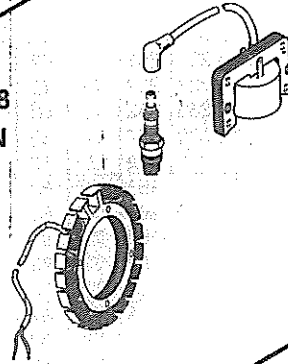

**Group 19
INSTRUMENT PANEL**

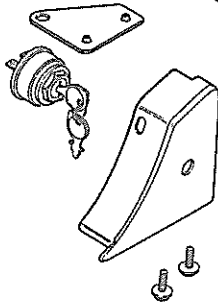

**Group 21
OIL PAN**

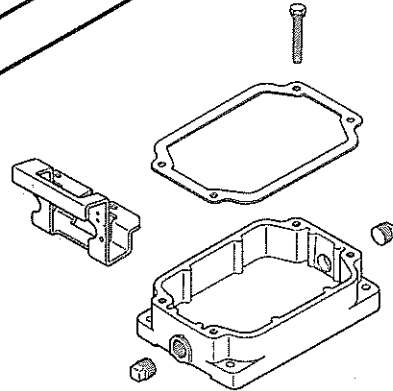

**Group 22
PISTON & ROD**

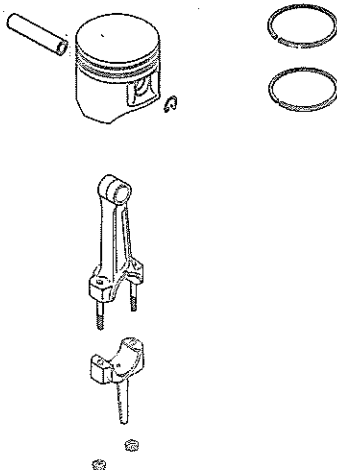

**Group 23
RETRACTABLE STARTER**

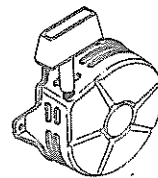

**Group 32
OIL LEVEL
CUTOUT**

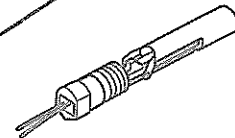

SPECIFICATION NUMBER INDEX

Group Title & Number	AIR INTAKE	BAFFLES & SHROUD	BREATHER & VENT	CAMSHAFT & VALVES	CARBURETOR	CRANKCASE	CRANKSHAFT	CYLINDER HEAD	DIPSTICK	ELECTRIC START	EXHAUST	FLYWHEEL	FUEL PUMP	FUEL TANK	GEAR REDUCTION	GOVERNOR	IGNITION	INSTRUMENT PANEL	OIL PAN	PISTON & ROD	RETRACTABLE STARTER	OIL LEVEL CUTOUT
	1	2	3	4	5	7	8	9	10	11	12	13	14	15	16	17	18	19	21	22	23	32
Page No.	8	9	10	11	12	15	16	17	18	19	20	22	23	25	28	29	35	37	38	39	40	42
Grid No.	A8	A9	A10	A11	A12	B1	B2	B3	B4	B5	B6	B8	B9	B11	B14	C1	C7	C9	C10	C11	C12	C14

Spec. No.	Variation Number																					
301500	130	502	17	73	233	252	73	82	38	-	89	178	71	124	-	500	260	-	99	500	-	-
301501	130	502	17	73	233	252	73	82	38	-	89	500	71	124	-	500	260	-	99	500	527	-
301502	130	510	17	73	233	252	73	82	38	143	89	180	71	124	-	501	265	56	99	500	-	-
301503	130	510	17	73	233	252	73	82	38	143	89	502	71	124	-	501	265	56	99	500	527	-
301504	130	509	17	73	233	252	134	82	38	-	89	500	71	124	-	502	272	58	99	500	527	-
301506	130	509	17	73	233	263	135	82	38	-	89	178	71	124	-	268	272	58	99	500	-	-
301507	130	509	17	73	233	263	135	82	38	-	89	500	71	124	-	268	272	58	99	500	527	-
301508	130	502	17	73	233	259	79	82	38	-	89	500	71	124	1	500	260	-	99	500	527	-
301509	142	514	17	73	218	252	73	83	37	-	87	500	1	108	-	249	260	-	99	500	527	-
301511	142	503	17	73	216	257	73	82	38	143	91	182	71	513	-	201	264	-	94	500	-	-
301512	130	502	17	73	219	258	131	82	38	-	89	500	71	514	-	213	260	-	91	500	527	-
301513	130	503	17	73	219	258	131	82	38	143	89	501	71	514	-	213	267	-	91	500	527	-
301514	130	502	17	73	219	257	131	82	38	-	61	500	71	516	-	505	268	-	1	16	527	-
301515	130	502	17	73	219	259	73	82	38	-	89	500	71	540	-	281	260	-	98	500	527	-
301517	144	503	17	73	233	259	137	82	38	143	-	184	71	529	-	278	295	-	1	500	-	-
301520	144	503	17	73	206	259	137	82	38	143	-	184	1	110	-	220	295	-	1	500	-	-
301521	130	502	17	73	219	259	79	82	38	-	504	500	71	514	1	272	260	-	99	500	527	-
301523	144	503	17	73	208	259	137	82	38	143	-	184	75	110	-	278	295	-	1	500	-	-
301525	130	512	17	73	219	257	73	82	38	-	92	500	71	540	-	271	260	-	1	16	527	-
301526	130	500	17	73	219	259	73	82	38	-	91	500	71	137	-	218	275	-	99	500	527	-
301527	130	503	17	73	201	252	73	82	38	143	91	180	71	113	-	217	274	57	99	16	-	-
301529	130	503	17	73	219	257	131	82	38	143	61	501	71	523	-	505	269	-	1	500	527	-
301532	130	502	17	73	201	252	73	82	38	-	89	500	71	118	-	218	260	-	99	500	527	-
301538	501	504	17	73	233	257	73	82	38	-	89	500	71	125	-	503	260	-	99	16	527	-
301539	130	502	17	73	205	252	73	82	38	-	91	500	71	540	-	270	260	-	99	500	527	-
301541	130	502	17	73	219	252	73	82	38	-	95	500	71	124	-	267	260	-	99	500	527	-
301542	130	502	17	73	219	252	73	82	38	-	95	500	71	124	-	267	260	-	99	500	527	-
301543	130	502	17	73	219	259	79	82	38	-	89	500	71	124	1	211	260	-	99	500	527	-
301545	143	505	17	73	219	257	73	82	38	143	89	180	71	125	-	506	265	56	99	16	-	-
301546	130	509	17	73	233	252	134	82	38	-	89	500	71	513	-	215	272	58	100	16	527	2
301547	130	502	17	73	219	252	73	82	38	-	91	500	71	124	-	507	260	-	99	16	527	-
301548	130	502	17	73	219	258	131	82	38	-	89	500	92	139	-	508	279	-	91	16	527	-
301549	130	503	17	73	219	258	131	82	38	143	89	501	92	132	-	508	280	-	91	16	527	-
301550	130	503	17	73	219	259	79	82	38	143	89	180	71	113	-	506	265	56	99	16	-	-
301551	130	502	17	73	233	257	73	82	38	-	92	500	71	124	-	263	283	-	23	16	527	-
301552	130	503	17	73	219	252	73	82	38	143	-	180	81	110	-	509	295	-	99	16	-	-
301553	132	507	17	73	93	252	126	70	38	-	-	500	85	-	-	169	281	59	101	16	527	3
301554	500	501	17	73	219	259	73	82	38	-	91	500	71	137	-	504	275	-	100	16	527	1
301556	501	503	16	73	210	257	73	82	38	143	96	181	89	-	-	246	269	-	1	16	-	-
301557	130	510	17	73	219	263	80	82	38	143	89	180	71	130	-	264	288	56	100	16	-	2
301558	136	347	17	73	219	252	73	82	38	143	94	180	71	131	-	510	265	-	99	16	-	-
301559	142	506	17	73	217	259	73	83	37	143	98	180	1	108	-	248	274	-	98	16	-	-
301560	130	358	17	73	219	257	73	85	38	-	504	189	71	133	-	259	260	-	523	16	532	-
301562	-	509	2	73	93	252	73	82	38	-	89	178	88	137	-	147	272	58	23	16	-	-
301563	130	508	17	73	219	266	73	70	-	143	-	180	89	-	-	511	272	-	99	16	-	-
301564	136	345	17	73	219	252	73	82	38	-	-	500	71	137	-	255	260	-	99	16	527	-
301565	142	508	17	73	216	266	73	70	1	143	-	180	79	-	-	512	260	-	23	16	-	-
301566	130	509	17	73	219	263	80	82	38	-	89	500	71	140	-	513	287	58	100	16	527	2
301567	130	512	17	73	219	263	135	82	38	-	89	500	71	124	-	514	272	58	99	16	527	-
301568	130	507	17	73	219	252	73	70	38	-	97	190	79	-	-	515	260	-	100	16	-	1

SPECIFICATION NUMBER INDEX

Group Title & Number	AIR INTAKE	BAFFLES & SHROUD	BREATHER & VENT	CAMSHAFT & VALVES	CARBURETOR	CRANKCASE	CRANKSHAFT	CYLINDER HEAD	DIPSTICK	ELECTRIC START	EXHAUST	FLYWHEEL	FUEL PUMP	FUEL TANK	GEAR REDUCTION	GOVERNOR	IGNITION	INSTRUMENT PANEL	OIL PAN	PISTON & ROD	RETRACTABLE STARTER	OIL LEVEL CUTOFF
	1	2	3	4	5	7	8	9	10	11	12	13	14	15	16	17	18	19	21	22	23	32
Page No.	8	9	10	11	12	15	16	17	18	19	20	22	23	25	28	29	35	37	38	39	40	42
Grid No.	A8	A9	A10	A11	A12	B1	B2	B3	B4	B5	B6	B8	B9	B11	B14	C1	C7	C9	C10	C11	C12	C14

Spec. No.	Variation Number																					
301570	130	502	17	73	233	257	73	82	38	-	89	500	71	124	-	282	291	-	99	16	527	-
301571	130	508	17	73	219	266	73	70	-	143	89	180	71	-	-	511	272	-	99	16	-	-
301572	130	502	17	73	233	252	73	82	38	-	89	179	71	124	-	515	260	-	99	16	33	-
301573	130	508	17	73	219	266	73	70	-	143	89	180	71	-	-	511	272	-	100	16	-	1
301574	136	364	17	73	233	252	134	70	37	-	-	500	82	-	-	239	272	61	99	16	527	-
301577	130	502	17	73	233	259	79	82	38	-	99	179	71	124	1	515	260	-	99	16	9	-
301578	130	508	17	73	233	259	73	70	38	143	-	180	79	-	-	248	286	-	99	16	-	-
301580	130	508	17	73	219	259	73	70	38	143	89	180	79	-	-	511	272	-	100	16	-	1
301581	143	505	17	73	219	252	73	82	38	143	-	184	71	125	-	264	265	-	100	16	33	1
301582	130	508	17	73	219	252	73	70	38	143	89	184	79	-	-	253	265	-	100	16	33	1
301583	130	502	17	73	219	252	73	82	38	-	89	179	71	124	-	266	260	-	99	16	9	2
301584	130	509	17	73	220	252	134	82	38	-	-	179	71	124	-	252	272	58	100	16	33	1
301585	130	502	17	73	220	252	73	82	38	-	89	179	71	124	-	250	593	-	99	16	33	-
301586	130	510	17	73	220	252	73	82	38	143	89	180	71	124	-	253	294	56	99	16	-	-
301587	130	502	17	73	220	252	73	82	38	-	89	179	71	124	-	250	260	-	99	16	9	-
301588	145	508	2	73	501	259	73	70	38	143	-	180	90	-	-	164	289	-	101	16	-	6
301589	130	509	17	73	233	263	135	82	38	-	89	178	71	124	-	516	272	58	99	16	-	-
301590	130	358	17	73	233	257	73	85	38	-	-	179	71	133	-	259	260	-	23	16	9	-
301592	130	509	17	73	233	252	73	82	38	-	89	179	71	124	-	252	272	58	99	16	33	-
301593	130	502	17	73	233	252	73	82	38	-	89	179	71	124	-	280	260	-	23	16	9	-
301594	132	355	17	73	235	252	126	70	38	-	-	179	70	-	-	169	281	59	23	16	33	8
301595	130	502	17	73	233	252	73	82	38	-	-	179	71	124	-	250	260	-	99	16	33	-
301596	130	502	17	73	219	257	73	82	38	-	61	179	71	137	-	269	590	-	1	16	9	-
301597	130	503	17	73	219	257	73	82	38	143	61	181	71	137	-	269	299	-	1	16	9	-
301598	130	502	17	73	233	252	73	82	38	-	89	184	71	124	-	250	292	-	99	16	33	-
301599	130	510	17	73	233	259	79	82	38	143	89	180	71	124	1	253	265	56	99	16	-	-
301600	132	355	2	73	235	252	126	70	38	-	-	179	94	-	-	169	281	59	101	16	33	8
301601	130	511	17	77	206	252	73	70	38	143	89	193	1	-	-	283	265	56	99	16	-	-
301603	136	363	17	73	219	252	73	82	38	143	590	180	71	137	-	285	265	56	99	16	-	-
301604	130	502	17	73	233	259	79	82	38	-	89	179	71	124	1	250	260	-	99	16	33	-
301605	130	513	17	73	219	263	135	82	38	143	89	184	71	124	-	257	265	56	99	16	33	-
301607	130	360	17	78	233	252	134	82	38	-	-	179	71	137	-	215	297	58	100	16	33	2
301608	130	502	17	73	233	258	131	82	38	-	89	179	71	139	-	265	279	-	91	16	33	-
301609	130	503	17	73	233	258	131	82	38	143	89	181	71	132	-	265	280	-	91	16	33	-
301611	148	502	17	73	219	259	73	82	38	-	89	179	71	140	-	286	260	-	98	16	33	-
301612	148	361	17	73	210	252	126	70	38	-	-	179	96	-	-	245	281	64	101	16	33	8
301613	130	502	17	73	233	259	73	82	38	-	89	179	71	124	-	288	260	-	99	16	33	-
301614	130	502	17	73	233	252	73	82	38	-	101	179	71	124	-	250	260	-	99	16	33	-
301615	149	503	17	73	237	252	73	82	38	143	-	180	81	110	-	262	295	-	99	16	-	-
301616	149	502	17	73	237	252	73	82	38	-	-	180	81	110	-	262	298	-	99	16	-	-
301617	149	358	17	73	233	252	73	85	38	-	102	179	71	141	-	250	290	-	100	16	33	2
301618	130	358	17	73	233	252	73	85	38	-	102	179	71	141	-	287	300	65	100	16	33	-
301619	130	358	17	73	233	252	73	85	38	-	102	179	71	141	-	250	290	-	100	16	33	-
301620	130	502	17	73	233	259	79	82	38	-	89	178	71	124	1	250	260	-	99	16	-	-
301621	130	509	17	73	233	259	73	82	38	-	89	179	71	124	-	290	272	58	99	16	9	-
301623	130	510	17	73	233	252	73	82	38	143	96	184	95	-	-	253	301	66	99	16	33	-
301624	130	347	17	73	233	258	131	82	38	143	89	181	71	132	-	265	280	-	91	16	9	-
301625	130	502	17	73	233	257	73	82	38	-	89	179	71	124	-	251	302	58	99	16	33	-
301626	130	510	17	73	233	252	134	82	38	143	89	180	71	124	-	252	265	56	99	16	-	-
301627	130	502	17	73	233	252	73	82	38	-	61	179	71	124	-	250	260	-	99	16	33	-

**Group 1
AIR INTAKE**

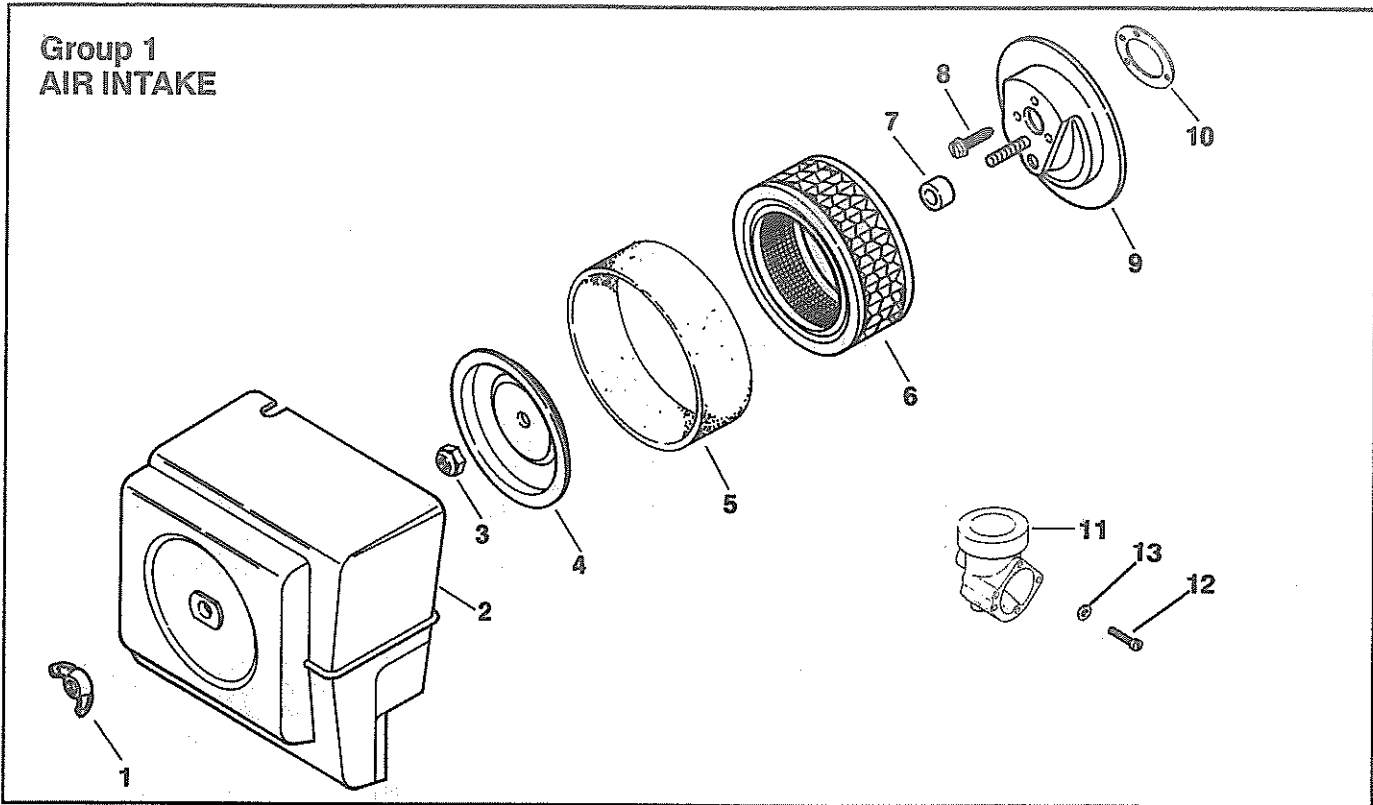

Index Number	Description Variation Number	Part Number	Index Number	Description Variation Number	Part Number
1	Wing nut 1/4-20 130,132,136,142,143,144,148,500,501	X-276-7	8	Screw, hex. wash. hd. 8-32x3/8" (3) 130,132,136,142,144,148,149, 500,501	X-67-59
2	Cover, air cleaner 130,136,500	41 096 29	9	Base, air cleaner (Use before serial no. 2208800012) (Replaced by Breather kit 41 743 02, also see Group 3 Breather & Vent, page 10) 130,136,142,144,148,149	41 094 14
2	Cover, air cleaner 142,144,148	41 096 30	9	Base, air cleaner (Use after serial no. 2208800002) 130,136,142,143,144,148,149	41 094 16
2	Cover, air cleaner 132	231055	9	Base, air cleaner 132	41 201 03
2	Cover, air cleaner Before serial no. 1813700012 use: After serial no. 1813700002 use: 149,501	41 096 28 41 082 01	9	Base air cleaner 500	41 094 16
3	Nut, jam 1/4-20 130,136,142,144,148,149,500,501	41 100 04	9	Base, air cleaner 501 Before serial no. 1813700012 use: After serial no. 1813700002 use:	41 094 16 41 094 15
4	Cover, air cleaner element 130,136,142,144,148,149,500,501	52 082 04	10	Gasket, air cleaner 130,132,136,142,144,145,148, 149,500,501	41 041 11
5	Element, precleaner 130,136,142,144,148,500	41 083 04	11	Elbow, air intake 145	41 054 06
5	Element, precleaner 149	45 083 01	12	Screw, R.H.M. 8-32x2" (2) 145	X-51-44
5	Element, precleaner (Use before serial no. 1813700012) 501	41 083 04	13	Washer, flat no. 8 (2) 145	X-25-79
6	Element, air cleaner 130,136,142,148,500,501	235116	NOT ILLUSTRATED		
6	Element, air cleaner 132	231847	Decal, air cleaner 130,136,149,500		41 113 02
6	Element, air cleaner 144	47 083 02	Decal, air cleaner 149,501		25 113 07
6	Element, air cleaner 149	45 083 02			
7	Seal 130,136,142,143,144,148,150	41 032 02			
7	Seal, air cleaner (Use after serial no. 1813700002) 501	41 032 05			

**Group 2
BAFFLES & SHROUD**

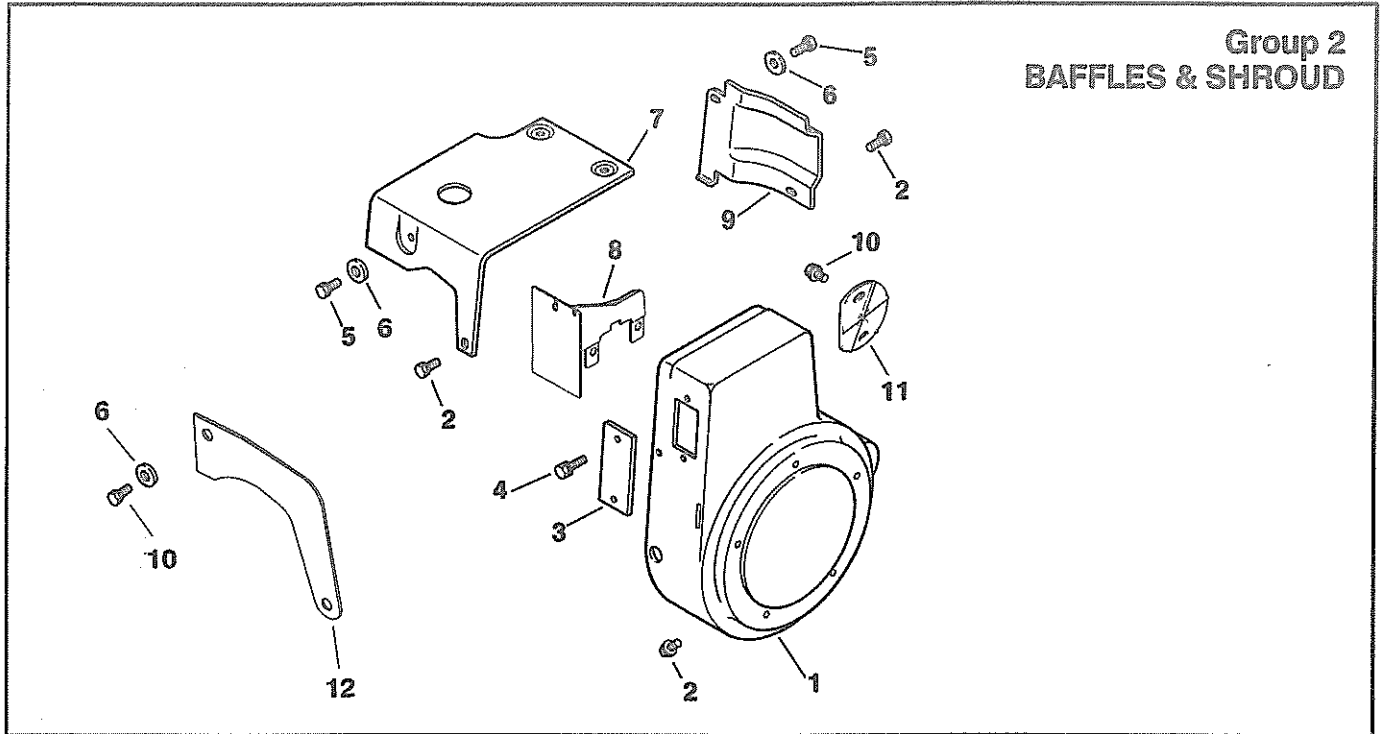

Index Number	Description Variation Number	Part Number	Index Number	Description Variation Number	Part Number
1	Housing, blower 345,347,358,360,363,364,365,500,501, 502,503,504,505,506,507,508,509,510, 512,513,514	41 027 47	7	Baffle, head 506,514	41 063 12
1	Housing, blower 361	41 027 48	7	Baffle, head 361,364,365,507,508	41 063 17
2	Screw, self tap 1/4-20x3/8" (4) 345,347,358,361,500,501,502,503,507, 508,512	X-67-83	7	Baffle head 358	41 063 18
2	Screw, self tap 1/4-20x3/8" (3) 360,363,364,365,504,505,506,509,510, 513,514	X-67-83	8	Baffle, blower housing 345,347,358,360,361,363,364,365,500, 501,502,503,504,505,506,507,508,509, 510,512,513,514	41 063 13
2	Screw, self tap 1/4-20x3/4" 504,505	X-67-62	9	Baffle, cylinder 345,347,360,361,365,500,501,502,503, 506,507,508,512,514	41 063 09
3	Cover, rectifier-regulator 345,347,358,361,364,500,501,502,503, 504,507,508,509,512,514	41 096 23*	10	Screw, pozidriv T.H. 1/4-20x5/8" (2) 345,358,360,361,364,500,501,502,504, 507,509,512,514	47 086 08
4	Screw, H.C. sems 1/4-20x1" (2) 345,347,358,361,364,500,501,502,503, 504,507,508,509,512,514	X-132-4*	11	Cover, starter 345,358,360,361,364,500,501,504,507, 509,512,514	41 096 25
5	Screw, H.C. sems 1/4-20x3/4" (2) 345,347,358,360,361,363,364,365,500, 501,502,503,504,505,506,507,508,509, 510,512,513,514	X-132-5	12	Baffle, side air 358,361,365,500,501,502,507,508	230757
6	Washer, plain 1/4" (2) 358,360,361,364,365,500,501,502,503, 504,505,506,507,508,509,510,512,513, 514	X-25-53	NOT ILLUSTRATED		
7	Baffle, head 345,347,360,363,500,501,502,503,504, 505,509,510,512,513	41 063 11		Decal, 8HP, white 500,501	41 113 04
				Decal, 8HP, white 365,502,503,504,505,506,507,508,509, 510,514	41 113 21
				Decal, 8HP, black 512,513	41 113 22

*Note: Order these parts according to design used on engine.

**Group 3
BREATHER & VENT**

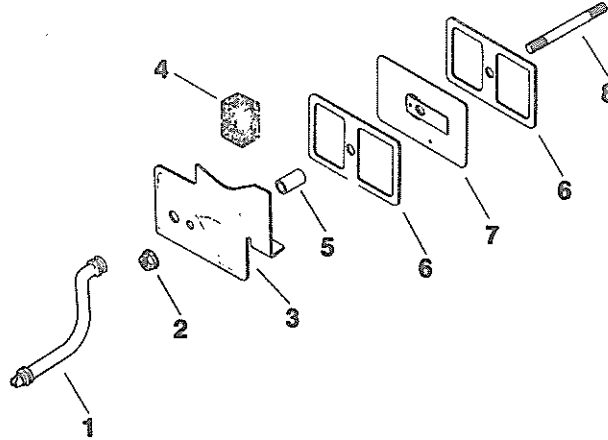

Index Number	Description Variation Number	Part Number	Index Number	Description Variation Number	Part Number
1	Hose, breather (Use before serial no. 2208800012 or replace with breather kit 41 743 02) 2,16,17	41 326 02	4	Filter (2) 2,16,17	231419
1	Hose, breather kit (Use after serial no. 2208800002) 17	41 326 03	5	Seal, breather 2,16,17	230046
2	Nut 1/4-20 2,16,17	X-799-1	6	Gasket, valve cover (2) 2,16,17	230048
3	Cover, valve 2	230774	7	Breather 2,16,17	230066
3	Cover, valve (Use before serial no. 2208800012 or replace with breather kit 41 743 02) 16	41 096 26	8	Stud, valve cover 2,16,17	230043
3	Cover, valve (Use after serial no. 2208800002) 17	41 096 31	NOT ILLUSTRATED Kit, breather (Includes 1 [41 326 03], 3 [41 096 31], air cleaner base 41 094 16) 17		41 743 02

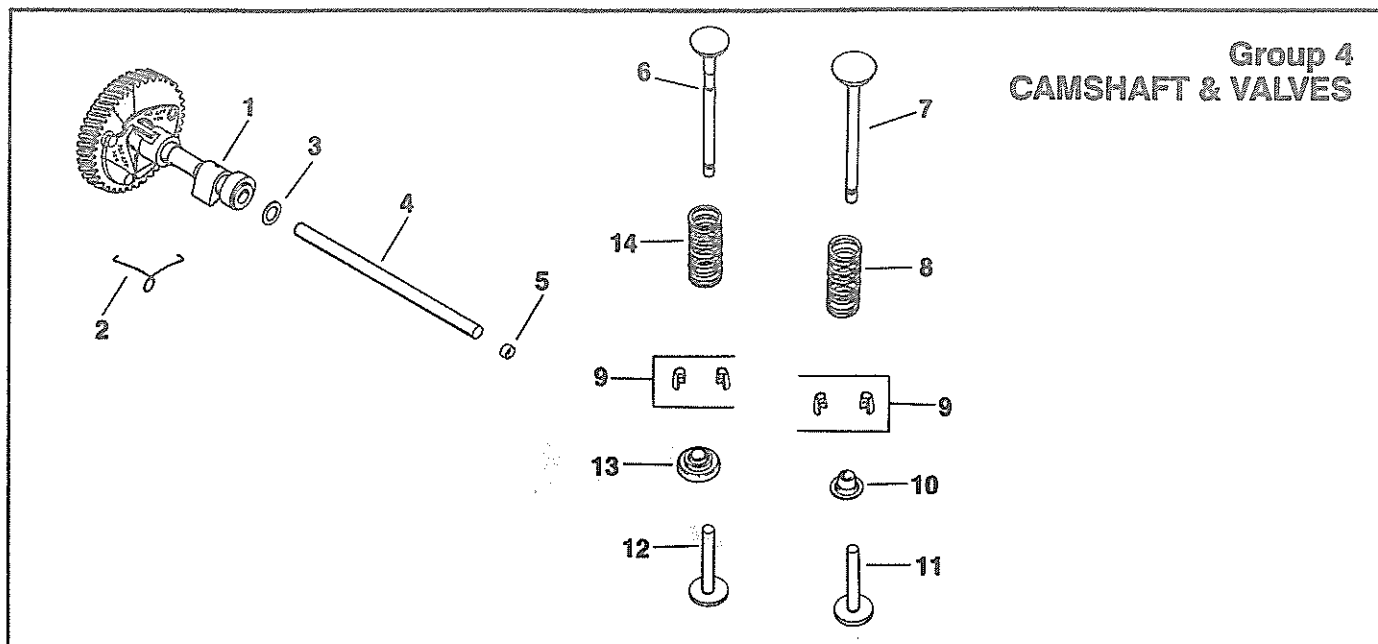

Index Number	Description Variation Number	Part Number	Index Number	Description Variation Number	Part Number
1	Camshaft assembly (Includes 2) 73,77	41 010 07	8	Spring, intake valve 73,77,78	230010
1	Kit, camshaft (Includes 2 and 12) 78	A-231511-S	9	Kit, retainer (2) 73,77,78	41 755 10
2	Spring, actuating 73,77,78	47 089 01	10	Retainer, intake spring 73,78	230011
3	Spacer, camshaft .005 (A.R.) 73,77,78	230293	10	Retainer, valve spring (2) 77	230011
3	Spacer, camshaft .010 (A.R.) 73,77,78	230294	11	Tappet, intake valve 73,77,78	230013
4	Pin, camshaft 73,77	41 380 03	12	Tappet, exhaust valve 73,77,78	232777
5	Plug, cup 7/16" 73,77	52 139 09	13	Rotator, exhaust valve 73,78	52 413 01
6	Valve, exhaust 73,77,78	230027	14	Spring, exhaust valve 73,78	230168
7	Valve, intake 73,77,78	230008	14	Spring, exhaust valve 77	230010

**Group 5
CARBURETOR**

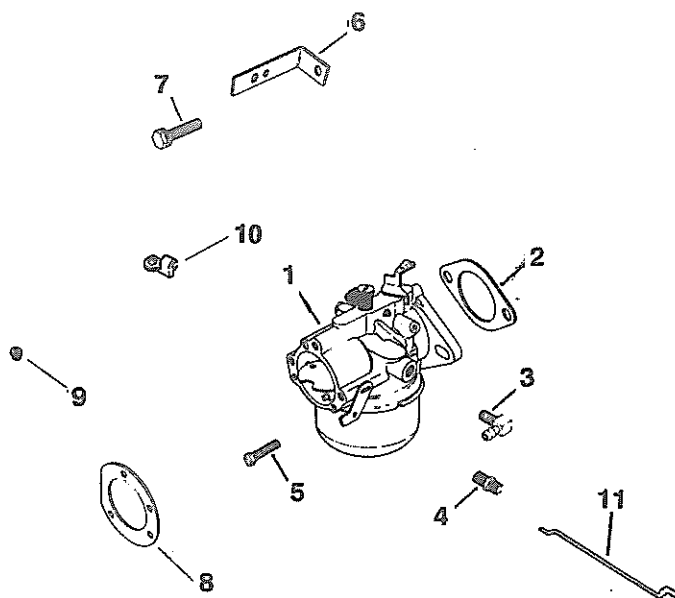

Note: For additional Carburetor components, see page 14.

Index Number	Description Variation Number	Part Number	Index Number	Description Variation Number	Part Number
Refer to Section 3 of Carburetor Reference Manual TP-2377-D, located in the Miscellaneous Special Service Parts Information Section of your Master Manual, for break down of the following carburetor assemblies:			1	Carburetor assembly 218 Before serial no. 1813600012 use: Adjustable jet carburetor After serial no. 1813600002 use: Kit, fixed jet carburetor (Includes 2,8,9 Carburetor assembly 41 053 24* or 41 053 26*) - Or use - Kit, adjustable carburetor (Includes 2,8,9 Carburetor assembly 41 053 27*)	41 053 18 41 853 04 41 853 07
1	Carburetor assembly 93	C-231738	1	Kit, fixed jet carburetor (Includes 2,8,10,11 carburetor assembly 41 053 24* or 41 053 26*) 216,217,219,220	41 853 04
1	Carburetor assembly 235 Before serial no. 1914500012 use: Adjustable jet assembly After serial no. 1914500002 use: Kit, adjustable jet carburetor (Includes 2,8,9 Carburetor assembly 41 053 28* or 41 053 34*)	C-231738 41 853 06	1	Kit, adjustable jet carburetor (Includes 2,8,9 Carburetor assembly 41 053 27*) 216,217,219,220	41 853 07
1	Carburetor assembly 201,208,210 Before serial no. 1824400012 use: Adjustable jet carburetor After serial no. 1824401002 use: Kit, fixed jet carburetor (Includes 2,8,10,11 Carburetor assembly 41 053 24* or 41 053 26*) - Or use - Kit, adjustable jet carburetor (Includes 2,8,9 Carburetor assembly 41 053 27*)	41 053 18 41 853 04 41 853 07	1	Kit, adjustable jet carburetor (Includes 2,8,9 Carburetor assembly 41 053 28* or 41 053 34*) (Use before serial no. 1823900012) 233	41 853 04 41 853 07
1	Carburetor assembly 205 Before serial no. 182300012 use: Adjustable jet carburetor After serial no. 1823000002 use: Kit, adjustable jet carburetor (Includes 2,8,9 Carburetor assembly 41 053 31*)	41 053 20 41 853 10	1	Kit, adjustable jet carburetor (Includes 2,8,9, Carburetor assembly 41 053 27*) (Use after serial no. 1823900002) 233	41 853 06 41 853 07
			1	Kit, adjustable jet carburetor (Includes 2,8,9 Carburetor assembly 41 053 36*) 237	41 853 12

Index Number	Description Variation Number	Part Number	Index Number	Description Variation Number	Part Number
1	Kit, adjustable jet carburetor (Includes 2,8,9 Carburetor assembly 41 053 28* or 41 053 34*) (Use before serial no. 1927100012)		6	Bracket, choke 210	41 126 37
	501	41 053 06	6	Bracket, choke 216	41 126 38
1	Carburetor assembly (Use after serial no. 1927100002)		7	Screw, H.C. soms 1/4-20x5/8" 210,216	X-132-5
	501	C-231738	8	Gasket, air cleaner 93,201,205,208,210,216,217,218, 219,220,233,235,237,501	41 041 11
2	Gasket, carburetor 93,201,205,206,208,210,216,217, 218,219,220,233,235,237,501	210223	9	Bushing, linkage 201,205,208,210,216,217,218,219, 220,233,237,501	25 158 08
3	Connector, hose (For 1/4" I.D. rubber hose) 93,201,205,210,216,220,233,235, 237,501	25 155 02	10	Bushing, linkage 201,208,210,216,217,218,219,220	25 158 09
3	Connector, elbow (For 3/16" I.D. rubber hose) 217,218	X-391-11	11	Linkage, throttle (Use only with kit 41 053 04) 216,217,218,219,233	25 079 01
4	Connector, straight (For metal fuel line) 208	231509	*NOTE: Carburetors are for information only, not available separately.		
5	Screw, sltd. hd. 1/4-20x3/4" (2) 93,201,205,206,208,210,216,217, 218,219,220,233,235,237,501	X-140-1			

**CARBURETOR
(Cont'd)**

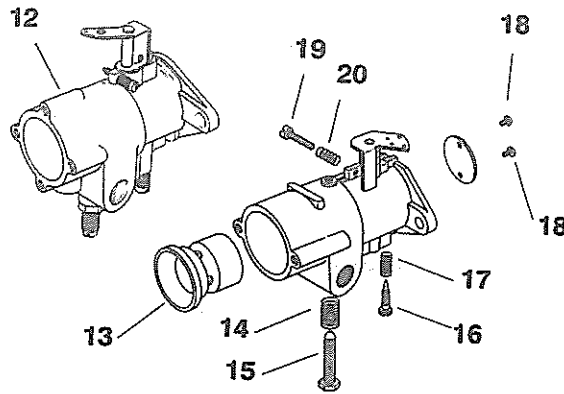

Note: For additional Carburetor components, see page 12.

Index Number	Description Variation Number	Part Number	Index Number	Description Variation Number	Part Number
12	Carburetor assembly (Includes 14-20) 206	46 053 04	17	Spring, idle adjustment screw 206	234208
13	Venturi (Discontinued not available at Kohler Co.)	234212	18	Screw, throttle plate (2) 206	234209
14	Spring, load adjustment screw 206	234207	19	Screw, idle stop 206	234210
15	Screw, load adjustment 206	232694	20	Spring, idle stop screw 206	234208
16	Screw, idle adjustment 206	234206	*NOTE: Carburetors are for information only, not available separately.		

**Group 7
CRANKCASE**

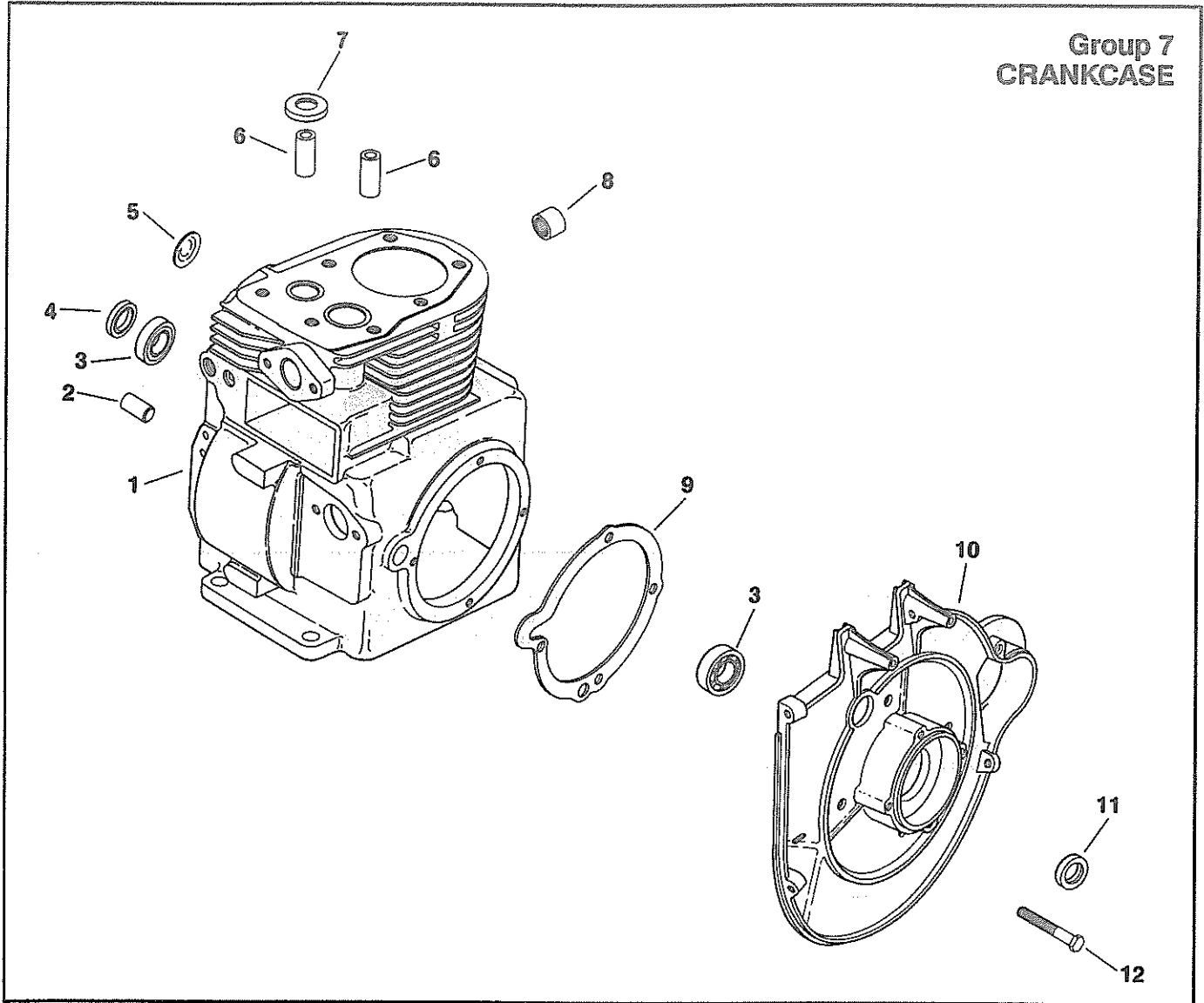

Index Number	Description Variation Number	Part Number	Index Number	Description Variation Number	Part Number
1	Cylinder block (Includes items 6,7, and 8) (Service with a SHORT BLOCK or MINIBLOCK. Refer to M8 Selection Guide TP-2248-C.)		7	Insert, exhaust valve 252,257,258,259,263	230170
2	Shaft, governor 252,257,258,259,263	230125-S	8	Bearing 252,257,258,259,263	234866
3	Bearing, ball (2) 252,257,258,259,263	231625	9	Gasket, bearing plate 252,257,258,259	41 041 07
4	Seal, rear oil 252,257,258,259,263	X-583-2	9	Gasket, bearing plate (4) 263	41 041 08
5	Plug, expansion 252,257,258,259,263	X-230-11	10	Plate, bearing 252,257,258,259,263	41 009 02
6	Guide, valve (2) 252,257,258,259,263	230007-S	11	Seal, front oil 252,257,258,259,263	X-583-1
			12	Screw, H.C. sems 1/4-20x3/4" (4) 252,257,258,259,263	X-176-1

**Group 8
CRANKSHAFT**

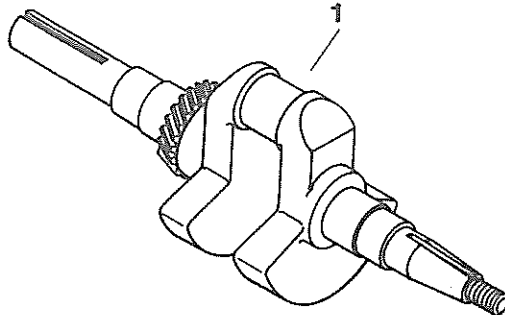

Index Number	Description Variation Number	Part Number	Index Number	Description Variation Number	Part Number
1	Crankshaft (1" dia. x3-1/4" - tapped P.T.O.) 73	231767*	1	Crankshaft (3/4" dia. x2-11/16" - tapped P.T.O.) 131	41 014 10*
1	Crankshaft (1-3/32" dia. x1-15/16" - gear reduction) 79	231805*	1	Crankshaft (7/8" dia. x4-5/16" - taper P.T.O.) 134	41 014 14*
1	Crankshaft (1" dia. x3-15/16" - pump) 80	231807*	1	Crankshaft (3-5/8" dia x1" - threaded P.T.O.) 135	41 014 12*
1	Crankshaft (3/4" dia. x3-3/16" - tapped end) 106	234817*	1	Crankshaft (3/4" dia. x3-1/2" - P.T.O.) 137	41 014 15*
1	Crankshaft (31/32" dia. x3-15/16" - tapped 1-24) 126	41 014 06*	*Note: Crankshaft dimensions are for P.T.O. end, outside the cylinder block.		

Group 9
CYLINDER HEAD

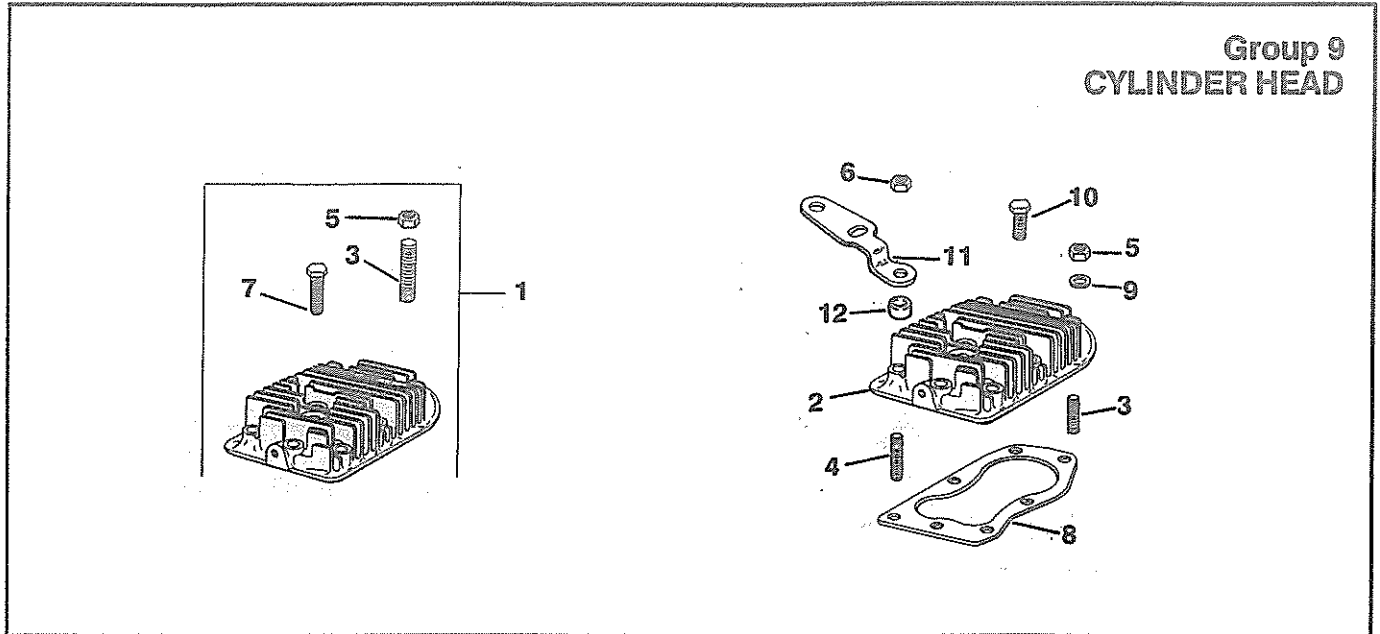

Index Number	Description Variation Number	Part Number	Index Number	Description Variation Number	Part Number
1	Kit, cylinder head (Includes 3,5,7) 70,82,83	41 755 25	7	Screw, H.C. sems 1/4-20x3/4" 70,82,83	X-132-5
2	Head, cylinder 85	41 015 09	8	Gasket, head 70,82,83,85	41 041 10
3	Stud, 5/16-18x2" (5) 85	52 072 15	9	Washer, plain 5/16" (5) 82	220534
3	Stud, 5/16-18x2" (2) 70,82,83,85	52 072 15	9	Washer, plain 5/16" (7) 70,83,85	220534
4	Stud, 5/16-18x2-5/8" (2) 85	X-352-35	10	Screw, hex. hd. 5/16-18x1-1/2" (5) 70,82,83	41 086 02
5	Nut, hex. 5/16-18 (2) 70,82,83	X-82-2	11	Strap, lifting (Replaced by 41 445 07) 83	41 445 05
5	Nut, hex. 5/16-18 (7) 85	X-82-2	12	Spacer (2) 85	X-410-89
6	Nut, hex. 5/16-18 (2) 85	X-77-2			

**Group 10
DIPSTICK**

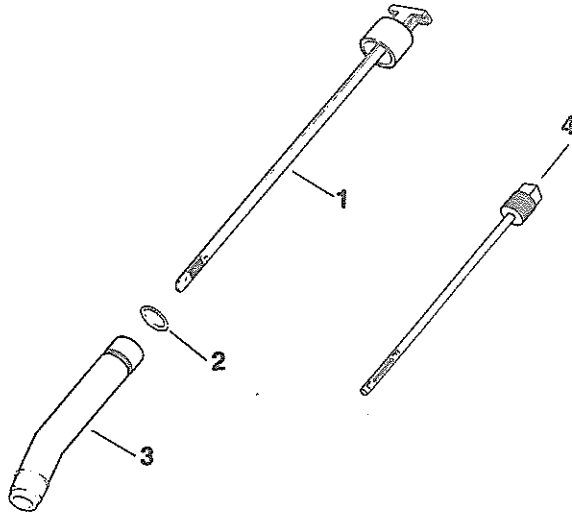

Index Number	Description Variation Number	Part Number	Index Number	Description Variation Number	Part Number
1	Dipstick 16-7/16" blade 37	41 038 13	3	Tube, oil fill 8" 37	41 123 20
1	Dipstick 12-13/16" blade 38	41 038 14	3	Tube, oil fill 4-3/8" 38	41 123 19
2	O-ring 37,38	41 153 01	4	Dipstick 6-9/16" blade 1	230092

Group 11
ELECTRIC START

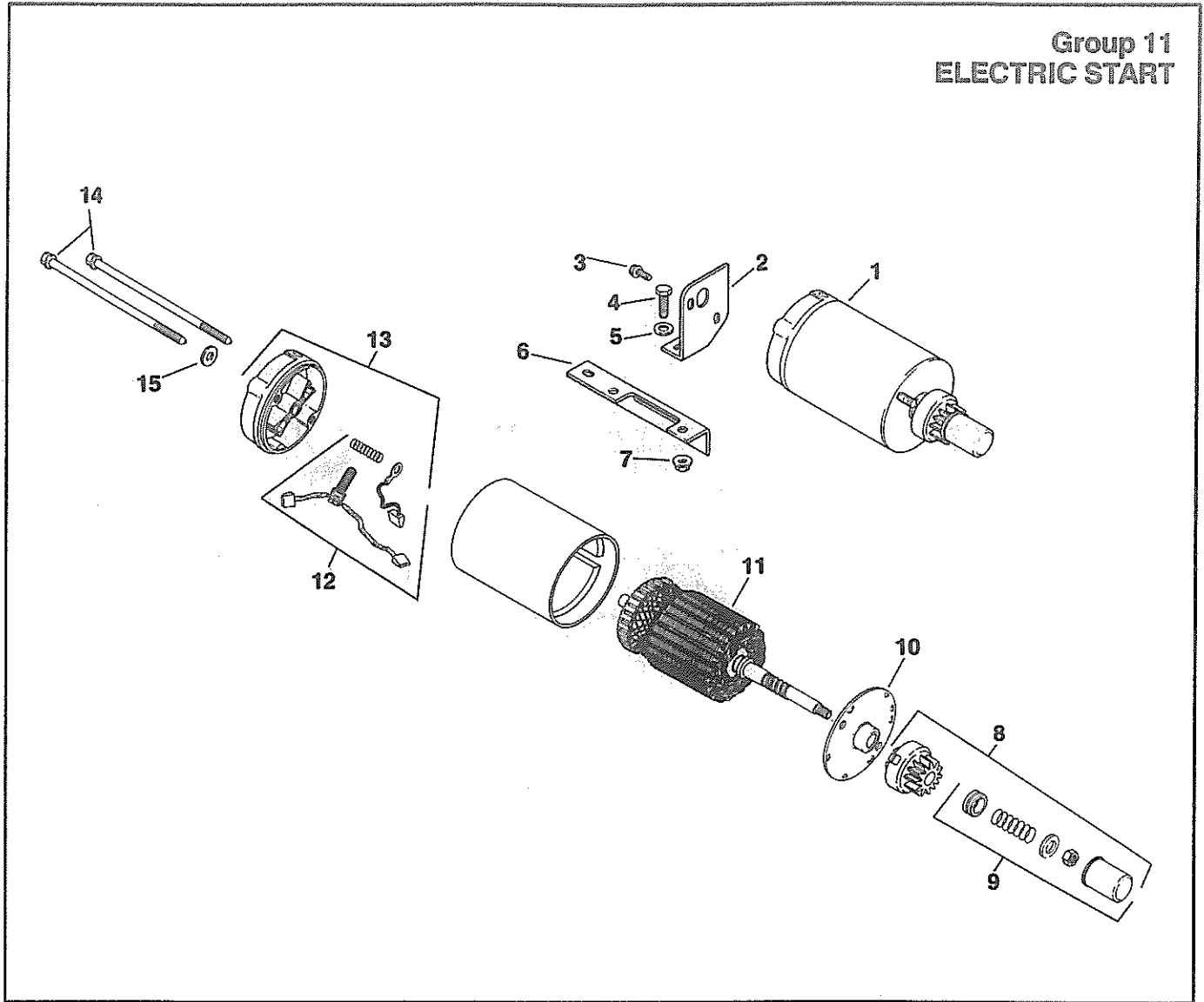

Index Number	Description Variation Number	Part Number	Index Number	Description Variation Number	Part Number
1	Starter assembly (Includes 8 thru 15) 143	41 098 04	10	Cap, drive end 143	41 227 03
2	Brace, starter tail 143	41 120 06	11	Armature 143	45 170 02
3	Screw, hex. wash. hd. 1/4-20x3/4" 143	X-67-62	12	Kit, brush & spring 143	52 755 15
4	Screw, H.C. 1/4-20x5/8" 143	X-5-1	13	Cap, commutator end (Includes 12) (Replaced by 52 227 03) 143	41 227 04
5	Washer, plain 1/4" 143	X-25-53	14	Bolt, thru 1/4-20x5-1/16" (2) 143	41 086 19
6	Bracket, solenoid & starter 143	41 126 25	15	Washer, plain 1/4" (Used on lower thru bolt only) 143	X-25-53
7	Palm nut 1/4-20 143	X-799-1		NOT ILLUSTRATED	
8	Kit, drive (Includes 9) 143	47 755 07		Tag, caution 143	25 450 03
9	Kit, drive parts 143	47 755 13			

Group 12
EXHAUST

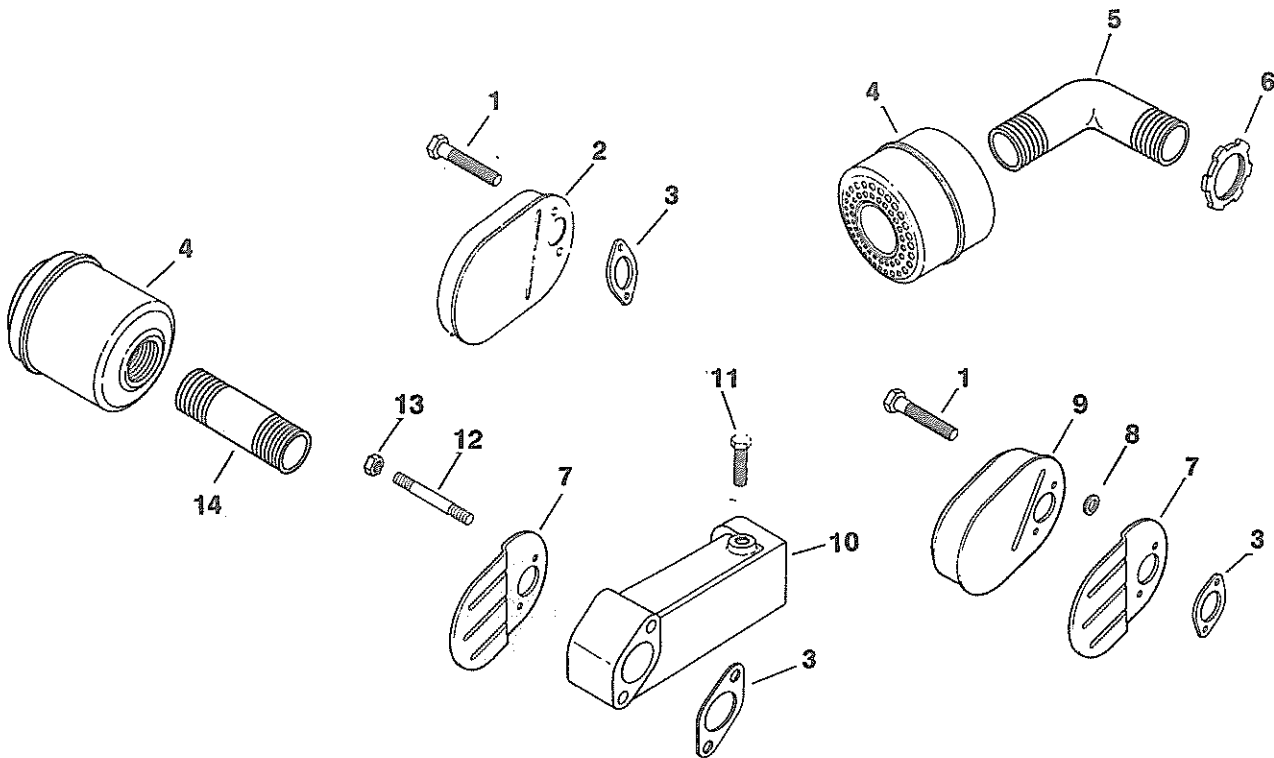

Note: For additional Exhaust components, see page 21.

Index Number	Description Variation Number	Part Number	Index Number	Description Variation Number	Part Number
1	Screw, hex. hd. 5/16-18x1-1/2" (2) 61,89,91	41 086 02	6	Nut, lock (2) (Use before serial no. 1833000012) 504	AC-1536
1	Screw, hex. hd. 5/16-18x2" (2) 95	X-6-29	7	Baffle, heat 89,91	41 063 10
2	Muffler 61	41 068 03	7	Baffle, heat (2) 95	41 063 10
3	Gasket, muffler 61,89,91,95,102	41 041 01	8	Spacer (2) 95	265372
3	Gasket, muffler (Use after serial no. 1833000002) 504	41 041 01	9	Muffler 89,95,590	41 068 08
3	Gasket, muffler and exhaust (2) 590	41 041 01	9	Muffler, perforated 91	41 068 02
4	Muffler 94,101	230410	9	Muffler 102	41 068 11
4	Muffler (Use before serial no. 1833000012) 504	230410	10	Adapter, exhaust 102	41 029 06
5	Elbow, exhaust (Use before serial no. 183300002) 504	231820	11	Screw, hex. socket hd. cap 102	25 086 18
5	Elbow, exhaust 94	235194	12	Stud, 5/16-18x2" (2) 92,97	41 072 18
5	Elbow, street 99	230600	13	Nut, hex. 5/16-18 (2) 97	X-92-2
6	Nut, lock (2) 94,99	AC-1536	14	Nipple, 1x2" 99	41 136 02
			14	Nipple, 1x1-1/2" 101	41 136 04

**Group 12
EXHAUST
(Cont'd)**

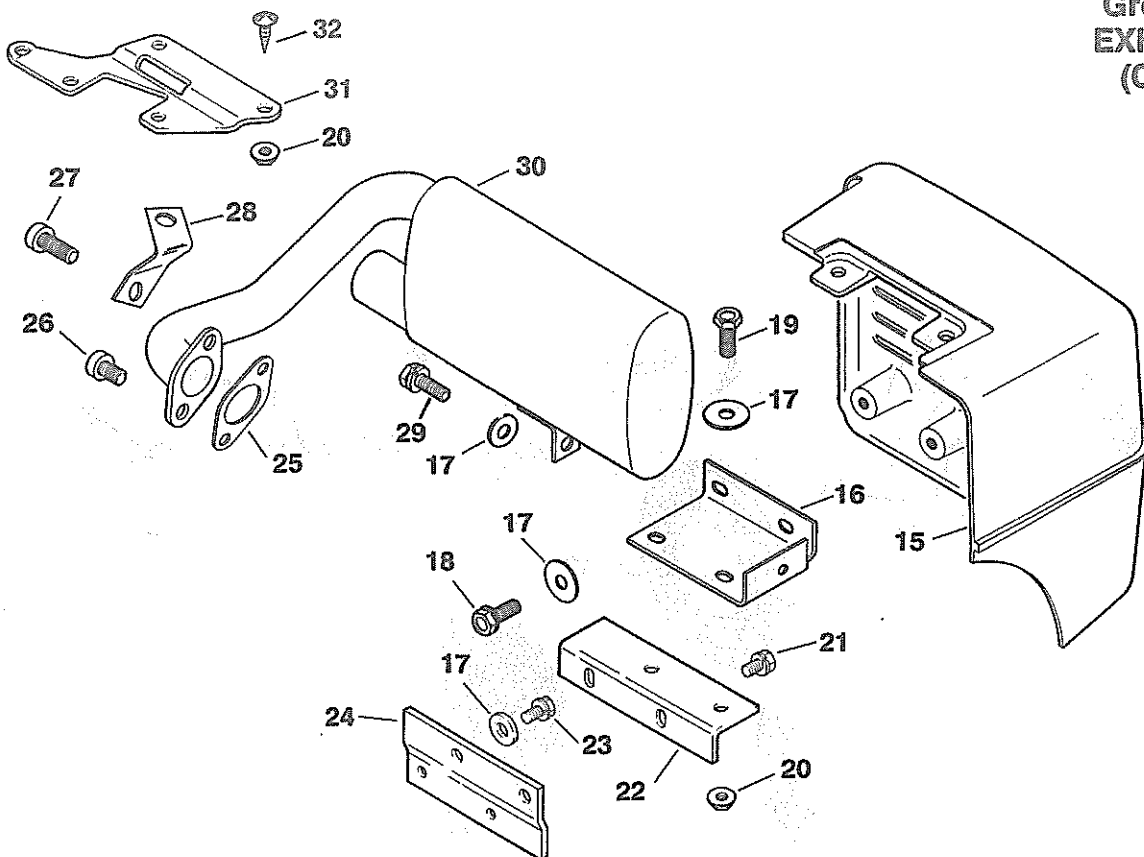

Note: For additional Exhaust components, see page 20.

Index Number	Description Variation Number	Part Number	Index Number	Description Variation Number	Part Number
15	Cover, muffler 87,96,98	41 096 21	26	Screw, hex. socket hd. cap 5/16-18x5/8" 87	25 086 18
16	Bracket, muffler & cover support 87,96,98	41 126 28	26	Screw, hex. socket hd. cap 5/16-18x5/8" (2) 96,98	25 086 18
17	Washer, plain 1/4" (7) 87	X-25-53	27	Screw, hex. socket hd. cap 5/16-18x2/4" 87	X-55-6
17	Washer, plain 1/4" (5) 96,98	X-25-53	28	Bracket, stabilizer 87,98	41 126 36
18	Screw, H.C. sems 1/4-20x7/8" (2) 87,96,98	X-132-7	29	Screw, H.C. sems 1/4-20x1/2" 87,96,98	X-132-6
19	Screw, H.C. 1/4-20x3/4" (2) 87,96,98	X-132-5	30	Muffler 87	41 068 07
20	Nut 1/4-20 (4) 87,96,98	X-799-1	30	Muffler 96,98	41 068 12
21	Screw, H.C. sems 1/4-20x3/8" (2) 87,96,98	X-132-1	31	Bracket, tank support 87,96,98	41 126 26
22	Bracket, fuel tank 87,96,98	41 126 29	32	Screw, truss hd. 1/4-20x5/8" 96,98	47 086 08
23	Screw, hex. hd. sems 3/8-16x3/4" (2) 87,96,98	41 086 21		NOT ILLUSTRATED	
24	Bracket, fuel tank support 87,96,98	41 126 30		Decal, caution 87,96,98	41 113 20
25	Gasket, exhaust 87,96,98	41 041 01			

Group 13
FLYWHEEL

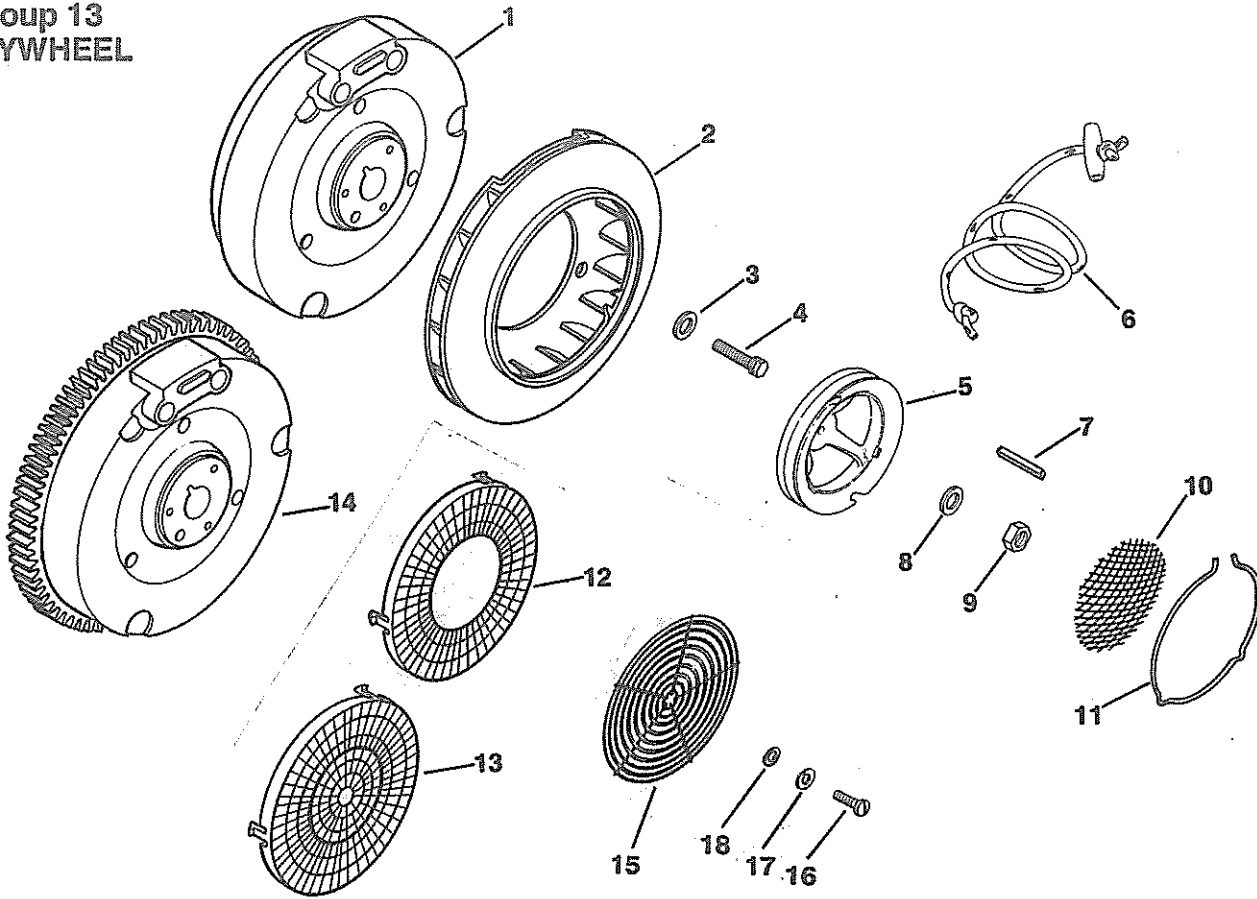

Index Number	Description Variation Number	Part Number	Index Number	Description Variation Number	Part Number
1	Flywheel 178,179,189,190	41 025 47	10	Screen 178	230098
2	Fan 178,179,180,181,182,184,189,190,193	41 157 01	11	Retainer 178	230363
3	Spacer 1/4" I.D.x3/8" O.D. (3) 178,179,180,181,182,184,189,190,193	25 431 01	12	Screen, grass 2-5/8" hole (Use before serial no. 1802800012) 500,501,502	41 162 11
4	Screw, hex. wash. hd. 1/4-20x1/2" (3) 178,179,180,181,182,184,189,190,193	25 086 14	13	Screen, grass 180,182,190,193	41 162 10
5	Pulley, rope start 178	41 093 08	14	Flywheel 180,184,193	41 025 46
6	Rope 178	A-230099	14	Flywheel 181,182	41 025 48
7	Key, square 3/16x1-3/8" 178,179,180,181,182,184,190,193	X-286-17	15	Guard, screen 193	41 314 03
8	Washer, plain 5/8" 178,179,180,181,182,184,189,190, 193	X-25-15	16	Screw, hex. hd. 10-24x1-3/8" (5) 193	41 086 16
9	Nut, hex. 5/8-18 178,179,180,181,182,184,189,190, 193	25 100 02	17	Washer, lock #10 (5) 193	X-19-1
			18	Washer, plain #10 (5) 193	25 468 03

**Group 14
FUEL PUMP**

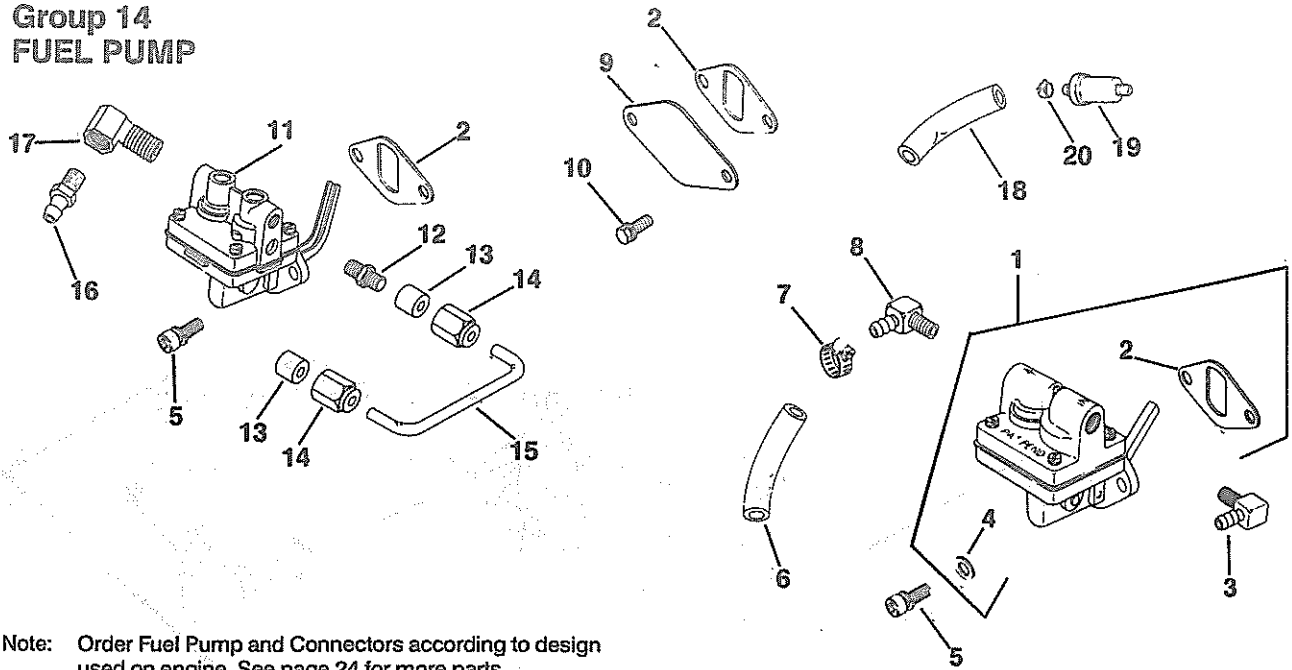

Note: Order Fuel Pump and Connectors according to design used on engine. See page 24 for more parts.

Index Number	Description Variation Number	Part Number	Index Number	Description Variation Number	Part Number
1	Kit, fuel pump (Includes 2,4,8,16) 70,85,94,96	41 559 01	10	Screw, H.C. sems 1/4-20x1/2" (2) 1	X-132-6
1	Kit, fuel pump (Includes 2,3,4,8 [qty. 2], 16) 71,79,81,82,88,89,90,92,95	41 559 02	11	Pump, fuel 75	A-231796
2	Gasket, fuel pump 1,70,75,90	25 041 05	12	Connector 75	231509
2	Gasket, fuel pump 71,79,81,82,85,89,92,94,95,96	25 041 09	13	Sleeve, tubing (2) 75	220547
3	Connector, 90° hose (For 3/16" I.D. rubber hose) 70,71,79,81,82,88,89,90,92,95	X-391-11	14	Nut 7/16x24 (2) 75	220786
4	Washer, plain 1/4" (2) 70,71,79,81,82,85,88,89,90,92,94,95,96	X-25-63	15	Line, fuel - metal 75	41 353 17
5	Screw, mach. FH. 1/4-20x5/8" (2) 71,79,81,82,85,88,89,90,92,94,95,96	X-174-2	16	Connector, straight 71,75,79,81,82,85,88,89,90,92,94,95,96	X-380-1
5	Screw, pozidriv T.H. 1/4-20x5/8" (2) 75	47 086 02	17	Elbow, street 75	X-555-2
6	Line, fuel 1/4" I.D. x 3" long 70,71,79,81,82,85,88,89,90,92,94,95,96	25 353 02	18	Line, fuel 81	41 353 13
6	Line, fuel 1/4" I.D. x 5" long (Connected to 3) 96	25 353 08	19	Filter, fuel 81,95	25 050 02
7	Clamp, hose (2) 70,71,79,81,82,85,88,89,90,92,94,95	X-426-9	20	Clamp, hose 81	25 237 01
7	Clamp, hose (3) 96	X-426-9	NOT ILLUSTRATED		
8	Connector, 90° hose (For 1/4" I.D. rubber hose) 71,79,81,82,85,88,89,90,92,94,95,96	25 155 02	Kit, fuel pump repair (Use only with pumps having letter "B" stamped on the body. This kit includes a diaphragm, diaphragm spring, valve assembly, valve gasket and pulsator diaphragm.) 75		230675
9	Cover, pump pad 1	240282			

**FUEL PUMP
(Cont'd)**

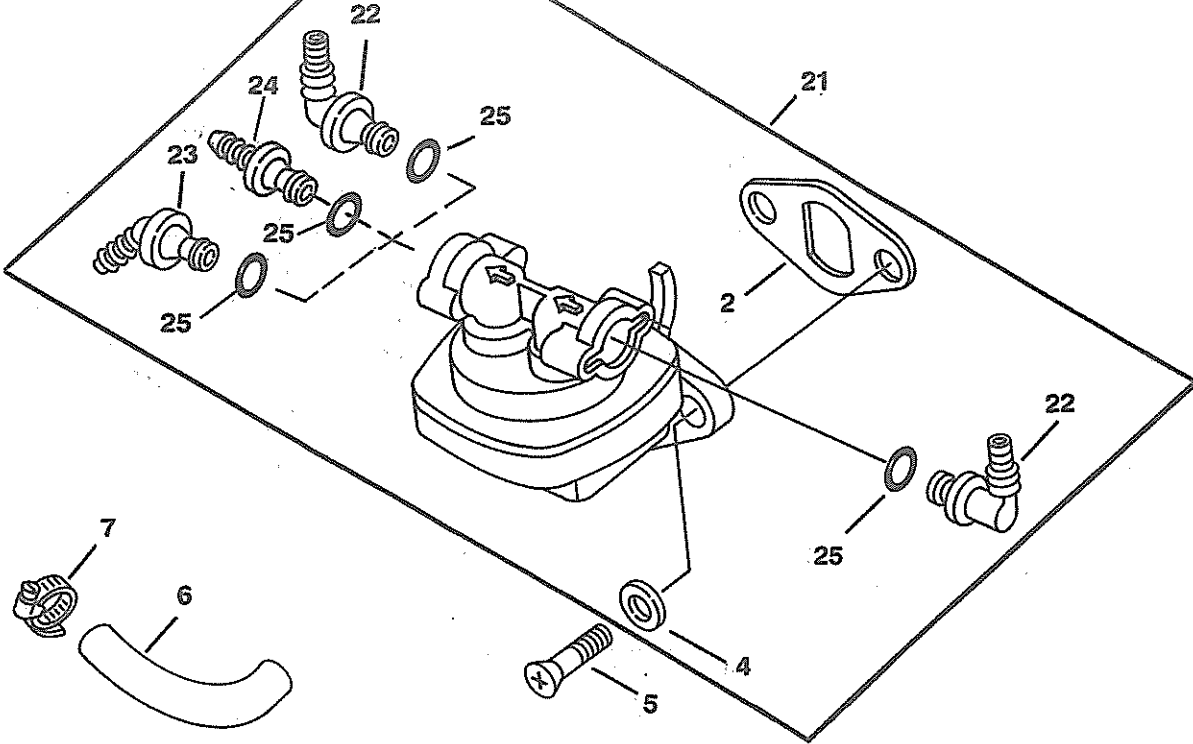

Note: Order Fuel Pump and Connectors according to design used on engine. See page 23 for more details.

Index Number	Description Variation Number	Part Number	Index Number	Description Variation Number	Part Number
21	Pump, fuel assembly (w/press-in fittings) (Flow arrows go right to left as shown) (Includes 2, [25 041 09], 3, 4, connectors 25 294 02, 03) 89,92	41 559 04	23	Connector, 45° press fit with O-ring (A.R.) (For 1/4" I.D. rubber hose) 70,89,92,94	25 294 02
21	Pump, fuel assembly (w/press-in fittings) (Flow arrows go right to left as shown) (Includes 2, [25 041 09], 3, 4, connectors 25 294 01, 02) 70,94	41 559 03	24	Connector, straight press fit with O-ring (A.R.) 89,92	25 294 03
22	Connector, 90° press fit with O-ring (A.R.) (For 1/4" I.D. rubber hose) 70,94	25 294 01	25	O-ring 70,89,92,94	25 294 03

**Group 15
FUEL TANK**

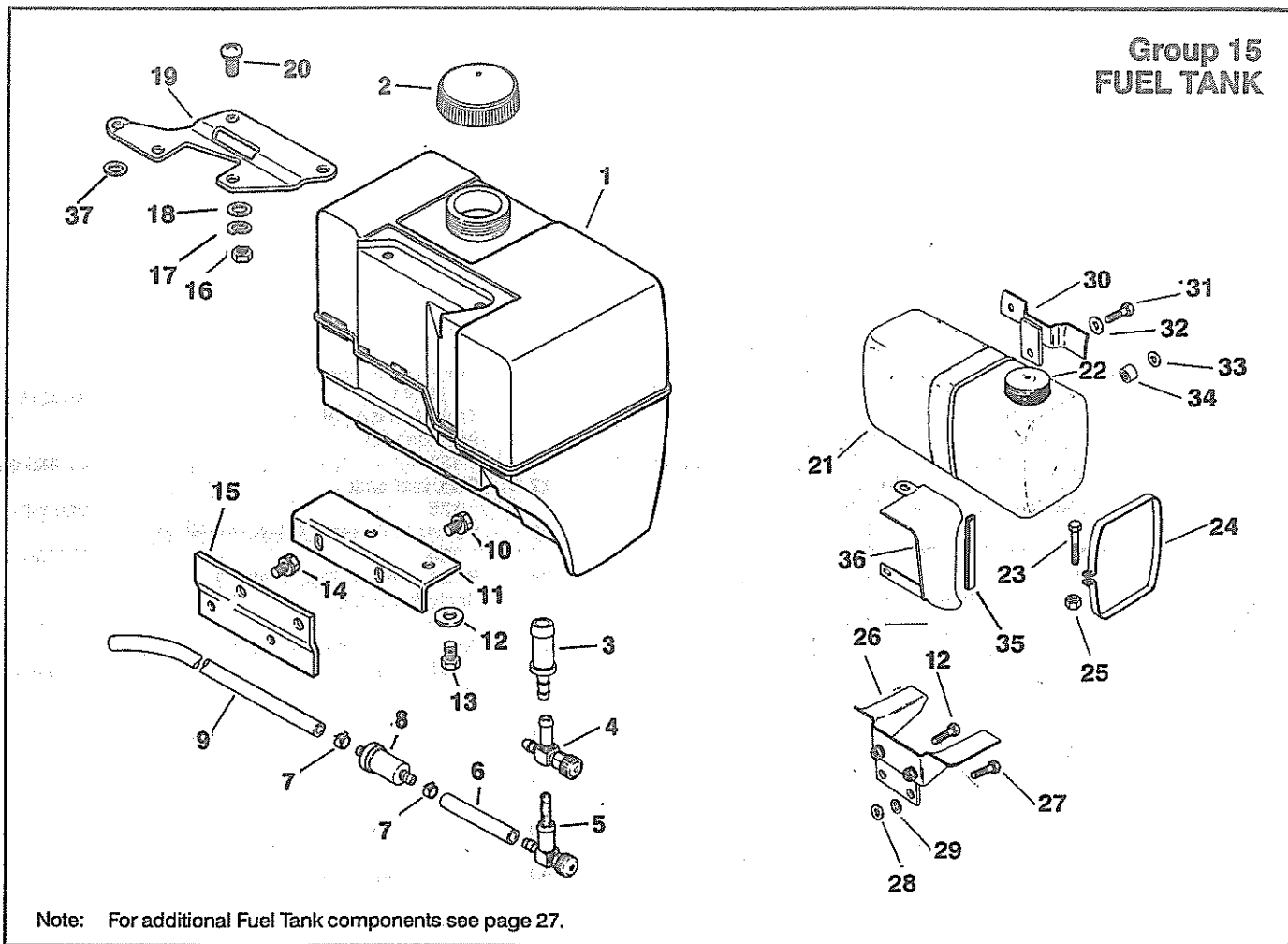

Index Number	Description Variation Number	Part Number	Index Number	Description Variation Number	Part Number
1	Tank, fuel (1/2" high filler neck) (Replaced by kit 41 755 29) 113,118,124,130,131,132,133,137,139, 513,514,516,523,529,540	41 065 14*	6	Line, fuel 3/16" I.D. x 2" long 113,118,124,131,133,141,513,523	41 353 10
1	Kit, fuel tank (3/4" high filler neck) (Includes 25 173 03 cap) 113,118,124,130,131,132,133,137,139, 141,513,514,516,523,529,540	41 755 29*	6	Line, fuel 3/16" I.D. x 2" long (Use after serial no. 1600200002) 529	41 353 10
2	Cap, fuel tank (Use on tank w/ 1/2" high filler neck) 113,118,124,130,131,132,133,137,138, 139,141,513,514,516,523,529,540	25 173 02*	7	Clamp (2) 113,118,125,130,132,139,140	25 237 01
2	Cap, fuel tank (Use on tank w/3/4" high filler neck) 113,118,124,130,131,132,133,137,139, 141,513,514,516,523,529,540	25 173 03*	7	Clamp (Before serial no. 1909700012 use [2]) (After serial no. 1909700002 use [4]) 124,513,14,516,523,540	25 237 01
3	Fitting, straight (Use before serial no. 1613300012) 514,540	41 294 01	7	Clamp (4) 131,133,137,141	25 237 01
4	Valve, shut-off 113,118,124,130,131,132,133,139,141, 513,514,516,523,529,540	25 462 01	7	Clamp (After serial no. 1600200002, but before serial no. 1909700012 use [2]) (After serial no. 1909700002 use [4]) 529	25 237 01
5	Valve, fuel shut-off 125	47 462 01	8	Filter, fuel (Replaced by 25 050 02) 113,118,124,131,133,137,141,513,516, 523	41 050 03
			8	Filter, fuel (Replaced by 25 050 02) (Use after serial no. 1600200002) 529	41 050 03

*Note: Order these parts according to design used on engine.

FUEL TANK
(Cont'd)

M8

Index Number	Description Variation Number	Part Number	Index Number	Description Variation Number	Part Number
9	Line, fuel 3/16" I.D. x 23" long 113,130,131,132	41 353 12	18	Spacer, 1/8x1/2" 133,141	X-384-2
9	Line, fuel 3/16" I.D. x 23" long (Use before serial no. 1909700012) 124,513,529,540	41 353 12	19	Bracket, upper tank support 110,113,118,124,125,130,131,132,137, 140,513,514,516,523,529,540	41 126 26
9	Line, fuel 3/16" I.D. x 23" long (Use before serial no. 1708600012) 514	41 353 12	19	Bracket, upper tank support 133,141	41 126 41
9	Line, fuel 3/16" I.D. x 23" long (Use before serial no. 180870012 and after serial no. 1909700002) 523	41 353 12	20	Screw, truss hd. nylock 1/4-20x5/8" (2) 110,113,118,124,130,131,132,137,140, 513,514,516,523,529,540	47 086 08
9	Line, fuel 3/16" I.D. x 20" long 124,133,137,140,141,516	41 353 11	20	Screw, self-tapping 125	25 086 23
9	Line, fuel 3/16" I.D. x 20" long (Use after serial no. 1909700002) 124,513,529,540	41 353 11	20	Screw, H.C. sems 1/4-20x1" (2) 133,141	X-132-4
9	Line, fuel 3/16" I.D. x 20" long (Use after serial no. 1708600002) 514	41 353 11	21	Tank, fuel 0.9 gal. (Includes 22) 125	41 065 02
9	Line, fuel 3/16" I.D. x 20" long (Use after serial no. 1808700002, but before serial no. 190970012) 523	41 353 11	22	Cap, fuel tank 125	220956
9	Line, fuel 3/16" I.D. x 18" long 125	41 353 16	23	Screw, H.C. sems 1/4-20x1-1/4" (2) 125	X-776-1
10	Screw, H.C. sems 1/4-20x3/8" (2) 113,118,124,130,131,132,133,137,140, 141,513,514,516,523,529,540	X-132-1	24	Strap, tank - 0.9 gal tank (2) (Includes 23,25) 125	A-234873
11	Bracket, lower tank 113,118,124,130,131,132,133,137,140, 141,513,514,523,540	41 126 29	25	Nut, elastic stop 1/4"-20 (2) 125	X-101-8
11	Bracket, lower tank (Use after serial no. 1808400002) 516,529	41 126 29	26	Bracket, lower tank 125	231595
12	Washer, plain 1/4" (2) 113,118,124,130,131,132,133,137,140, 141,513,514,523,540	X-25-53	27	Screw, H.C. sems 3/8-16x1-1/4" (2) 125	X-159-3
12	Washer, plain 1/4" (2) (Use after serial no. 1808400002) 516,529	X-25-53	28	Spacer (2) 125	X-400-91
13	Screw, H.C. 1/4-20x5/8" (2) 113,118,124,130,131,132,133,137,140, 141,513,514,523,540	X-5-1	29	Washer, plain 3/8" (2) 125	X-25-41
13	Screw, H.C. 1/4-20x5/8" (2) (Use after serial no. 1808400002) 516,529	X-5-1	30	Bracket, upper tank 125	A-234177
14	Screw, hex. hd. sems 3/8-16x3/4" (2) 113,118,124,130,131,132,133,137,140, 141,513,514,516,523,529,540	41 086 21	31	Screw, H.C. sems 1/4-20x1-1/4" 125	X-132-9
15	Bracket, lower tank support 113,118,124,130,131,132,133,137,140, 141,513,514,516,523,529,540	41 126 30	32	Washer, plain 17/64x3/4x1/16" 125	X-25-52
16	Nut, hex. 1/4-20 (2) 110	X-81-1	33	Washer, plain 17/64x3/4x1/8" 125	X-25-78
17	Washer, lock 1/4" (2) 110	X-20-1	34	Spacer 125	265861
			35	Seal, air cleaner 125	41 032 04
			36	Baffle, fuel tank 125	41 063 14
			37	Washer, plain 5/8" 125	X-25-44
			NOT ILLUSTRATED		
				Decal, fuel warning 113,124,125,130,140,141	25 113 10

FUEL TANK
TOP TANK
(Cont'd)

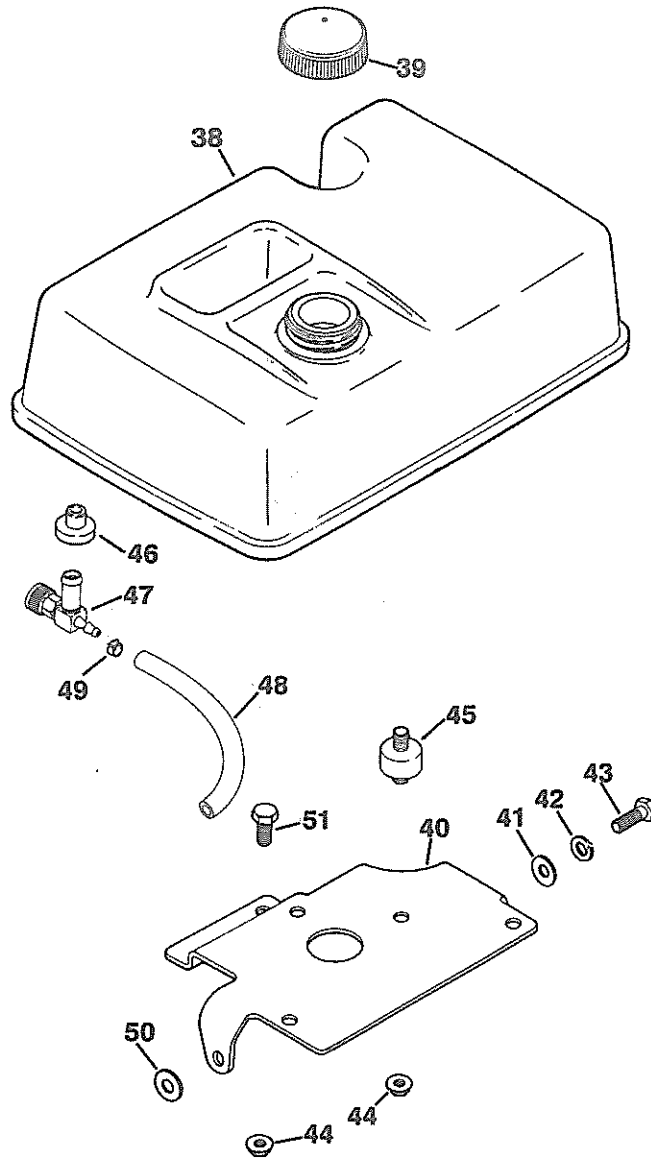

Note: For additional Fuel Tank components see page 25.

Index Number	Description Variation Number	Part Number	Index Number	Description Variation Number	Part Number
38	Tank, fuel 108	41 065 10	45	Mount, isolation (4) 108	41 366 01
39	Cap, fuel tank 108	25 173 02	46	Bushing, fuel tank 108	41 158 03
40	Bracket, tank 108	41 066 02	47	Valve, shut-off 108	25 462 01
41	Washer, plain 1/4" (2) 108	X-25-53	48	Line, fuel 3/16x6-1/2" 108	41 353 13
42	Washer, lock 1/4" 108	X-20-1	49	Clamp (2) 108	25 237 01
43	Screw, hex. mach. 1/4-20x7/8" 108	41 086 22	50	Washer, plain 1/4" 108	X-25-73
44	Palnut 1/4-20 (5) 108	X-799-1	51	Screw, H.C. 1/4-20x1" 108	X-5-7

**Group 16
GEAR REDUCTION**

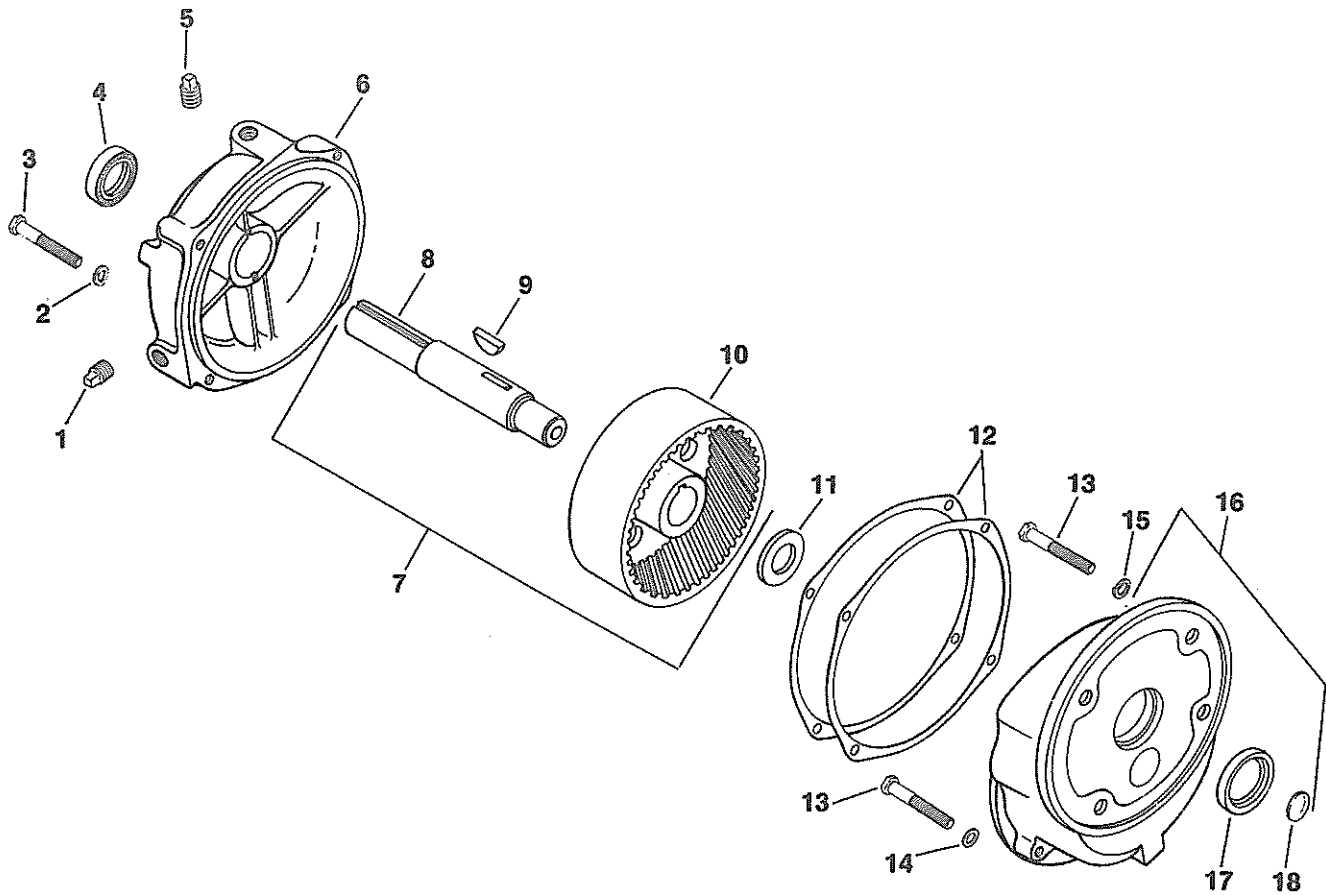

Index Number	Description Variation Number	Part Number	Index Number	Description Variation Number	Part Number
1	Plug, solid sq. hd. 1/4" N.R.T.F. 1	X-75-2	10	Gear, reduction 1	230213
2	Washer, lock 5/16" (4) 1	X-21-1	11	Bearing, thrust (2) 1	230219
3	Screw, H.C. 5/16-18x2" (4) 1	X-6-29	12	Gasket, gear cover .020 (A.R.) 1	234496
4	Seal, rear oil 1	X-583-2	13	Screw, H.C. 3/8-16x7/8" (4) 1	X-129-4
5	Plug, vented hex. cisk. 3/4" N.R.T.F. 1	41 139 01	14	Washer, plain 3/8" (2) 1	X-25-67
6	Cover, gear (Includes bushing) 1	A-230780	15	Washer, lock 3/8" (2) 1	X-22-1
7	Gear, reduction (Includes 8,9,&10) 1	A-234772	16	Housing, gear assembly (Includes 17&18) 1	A-230781
8	Shaft, gear reduction 1	230214	17	Seal, front oil 1	X-271-22
9	Key, woodruff #9 1	X-45-1	18	Plug, expansion 1	160037

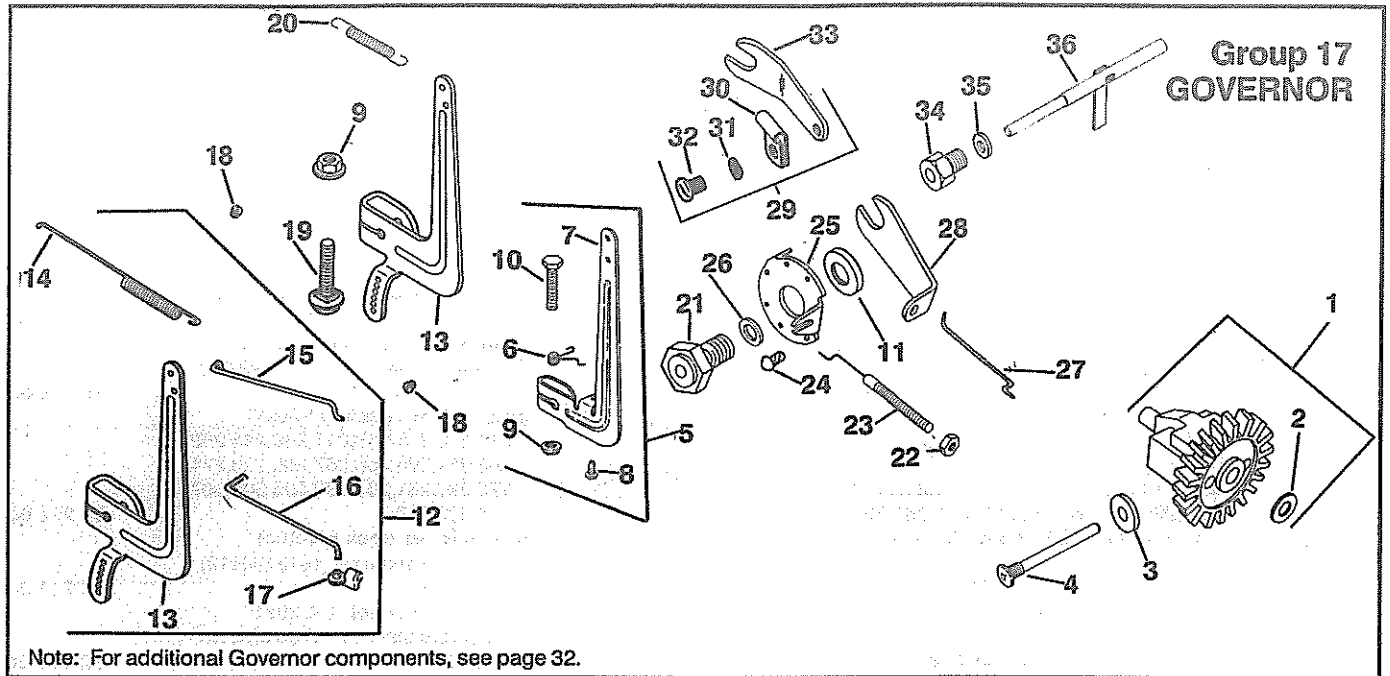

Index Number	Description Variation Number	Part Number	Index Number	Description Variation Number	Part Number
1	Kit, governor gear (Includes 2) 147,164,169,201,211,213,215,217 218,220,239,245,246,248,249,250, 251,252,253,255,257,259,262,263, 264,265,266,267,268,269,270,271, 272,278,280,281,282,283,285,286, 287,288,290,300,500,501,502,503, 504,505,506,507,508,509,510,511, 512,513,514,515,516	A-235743-S	5	Lever, governor assembly (Includes 6-10) (Use before serial no. 1824400002) 278	A-234178
2	Washer, thrust 147,164,169,201,211,213,215,217 218,220,239,245,246,248,249,250, 251,252,253,255,257,259,262,263, 264,265,266,267,268,269,270,271, 272,278,280,281,282,283,285,286, 287,288,290,300,500,501,502,503, 504,505,506,507,508,509,510,511, 512,513,514,515,516	237022	6	Spring, governor 147,164,201,220,245,278,512	232617
3	Washer, plain 1/4" 147,164,169,201,211,213,215,217, 218,220,239,245,246,248,249,250, 251,252,253,255,257,259,262,263, 264,265,266,267,268,269,270,271, 272,278,280,281,282,283,285,286, 287,288,290,300,500,501,502,503, 504,505,506,507,508,509,510,511, 512,513,514,515,516	X-25-12	7	Lever, governor 147,164,201,220,245,512	232614
4	Pin, governor stop 147,164,169,201,211,213,215,217, 218,220,239,245,246,248,249,250, 251,252,253,255,257,259,262,263, 264,265,266,267,268,269,270,271, 272,278,280,281,282,283,285,286, 287,288,290,300,500,501,502,503, 504,505,506,507,508,509,510,511, 512,513,514,515,516	231355	7	Lever, governor (Use before serial no. 1824400002) 278	232614
5	Lever, governor assembly (Includes 6-10) 147,164,201,220,245,512	A-234178	8	Screw, hex. wash. hd. 8-32x1/4" 147,164,201,220,245,278,512	X-67-46
			9	Pin nut, 1/4-20 147,164,201,211,213,215,217,218, 220,245,246,248,261,262,263,264, 265,266,267,269,270,271,272,278, 280,281,283,505,506,507,508,509, 510,512	X-799-1
			9	Pin nut, 1/4-20 (Use before serial no. 1706400012) 268,500,501,502	X-799-1
			9	Pin nut, 1/4-20 (Use before serial no. 1813600012) 249	X-799-1
			9	Pin nut, 1/4-20 (Use before serial no. 1824400012 and after serial no. 1918700002) 503	X-799-1
			10	Screw, hex. hd. 1/4-20x1" 147,164,201,220,245,278,512	25 086 16
			11	Shield, dust 169,239,245,251,252,257,278,286,290, 511,512,514	200440
			11	Shield, dust (Use after serial no. 1601760002) 220,278	200440
			11	Shield, dust (Use after serial no. 1813600002) 249,501,502	200440

Index Number	Description Variation Number	Part Number	Index Number	Description Variation Number	Part Number
11	Shield, dust (Use after serial no. 1822400002 but before serial no. 1918700012) 503,513	200440	18	Bushing, linkage retaining (Use after serial no. 1824400002, but before serial no. 1911000002) 147	25 158 08
12	Kit, governor linkage (Includes 13-17) 215,246,248,249,262,263,264,265,266, 267,269,270,271,272,280,281,284,502, 503,504,505,508,509,510,513	41 755 23	18	Bushing, linkage retaining (Use after serial no. 1706400002, but before serial no. 1813600012) 249,500,501	25 158 08
13	Lever, governor 211,213,215,218,246,248,262,263,264, 265,266,267,269,270,271,280,283,284, 289,504,505,506,507,508,509,510,513	41 090 14	18	Bushing, linkage retaining (2) 215,239,252	25 158 08
13	Lever, governor 511	41 090 15	18	Bushing, linkage retaining (2) (Use before serial no. 1706400012) 502	25 158 08
14	Spring, governor 211,213,215,217,218,246,248,262,263, 264,265,266,267,269,271,280,281,283, 284,504,505,506,507,508,509,510,513	41 089 12	19	Bolt, R.H. sq. neck 1/4-20x1" 211,213,215,218,217,246,248,262, 263,264,265,266,267,269,270,271, 272,280,281,283,289,505,506,507, 508,509,510	52 211 04
14	Spring, governor (Use before serial no. 1706400012) 268,500,501,502,	41 088 12	19	Bolt, R.H. sq. neck 1/4-20x1" (Use before serial no. 1813600012) 249	52 211 04
14	Spring, governor (Use after serial no. 1813600002) 249,271,272	41 089 12	19	Bolt, R.H. sq. neck 1/4-20x1" (Use before serial no. 1706400012) 500,501,502	52 211 04
14	Spring, governor (Use after serial no. 1823000002) 270	41 089 12	19	Bolt, R.H. sq. neck 1/4-20x1" (Use before serial no. 1824400012 and after serial no. 1918100002) 503	52 211 04
14	Spring, governor (Use after serial no. 1918700002) 503	41 089 12	20	Spring, linkage 169,215,220,502,511	230117
15	Linkage, governor 147,164,201,211,213,215,217,218,227, 239,245,246,248,249,252,262,263,264, 265,266,267,269,270,271,272,278,280, 281,283,284,502,503,504,505,508,509, 510,512,513,	230078	20	Spring, linkage (Use before serial no. 1611300012) 220	230117
16	Linkage, governor 147,164,201,211,213,215,217,218,227, 239,245,246,248,249,252,262,263,264, 265,266,267,269,270,271,272,278,280, 281,283,284,5002,503,504,505,508,509, 510,512,513,	25 079 01	21	Bushing, governor shaft 147,164,169,201,220,239,250,251, 252,253,255,257,259,278,282,285, 287,288,290,511,512,514,515,516	230476
17	Bushing, linkage retaining (2) (Use with linkage 25 079 01) 147,164,201,211,213,215,217,218,227, 239,245,246,248,249,252,262,263,264, 265,266,267,269,271,272,280,281,283, 284,502,504,505,508,509,510,512,513	25 158 09	21	Bushing, governor shaft (Use after serial no. 1706400002) 249,268,500,501,502	230476
17	Bushing, linkage retaining (2) 250,251,253,257,259,285,287,288,290, 516	25 158 09	21	Bushing, governor shaft (Use after serial no. 1824400002 but before serial no. 1918700012) 503	230476
17	Bushing, linkage retaining (Use before serial no. 1706400012) 500,501	25 158 09	22	Nut, hex. 8-32 213,215,217,239,246,248,250,251, 252,253,255,257,259,262,263,264, 265,266,267,269,270,271,272,282, 285,286,288,290,503,504,505,506, 507,508,509,510,511,513,514,515,516	X-72-4
17	Bushing, linkage retaining (2) (Use after serial no. 1824400002) 270,278,282,503	25 158 09	22	Nut, hex. 8-32 (2) 169,220,278,512	X-72-4
18	Bushing, linkage retaining 169,217,218,245,283	25 158 08	23	Arm, governor 220,278	220239
18	Bushing, linkage retaining (Use before serial no. 1813600012) 246,248,263,509,515	25 158 08	24	Screw, drive #2 147,201	X-67-5
18	Bushing, linkage retaining (Use before serial no. 1824400012) 282	25 158 08	25	Disc, regulating 201	220766
18	Bushing, linkage retaining (Use after serial no. 1813600002) 512	25 158 08	25	Disc, regulating 147,220,278	230149
			25	Disc, regulating 147	A-234837
			25	Disc, regulating 239,250,252,253,255,257,259,286, 288,290,511,514,515,516	41 274 15
			25	Disc, regulating (Use after serial no. 1813600002) 249	41 274 15

Index Number	Description Variation Number	Part Number	Index Number	Description Variation Number	Part Number
25	Disc, regulating (Use after serial no. 1706400002) 268,500,501,502	41 274 15	30	Clip, cable spring 201	210149
25	Disc, regulating (Use after serial no. 1824400002 but before serial no. 1918700012) 503	230476	31	Washer, lock #6 201	X-18-1
26	Spacer, disc 239,250,252,253,255,257,259,286, 288,290,511,514,515,516	41 112 11	32	Screw, sltd. pan hd. 8-32x3/8" 201	X-51-12
26	Spacer, disc (Use after serial no. 1813600002) 249	41 112 11	33	Bracket, speed control 201	232888
26	Spacer, disc (Use after serial no. 1706400002) 268,500,501,502	41 112 11	34	Bushing, governor 211,213,215,217,246,248,262,263, 264,265,266,270,271,272,281,283, 504,505,506,507,508,509,510,513	41 158 02
26	Spacer, disc (Use after serial no. 1824400002 but before serial no. 1918700012) 503	41 112 11	34	Bushing, governor (Use before serial no. 1706400002) 249,268,500,501,502	41 158 02
27	Linkage, throttle 239,250,252,253,255,257,259,286, 288,290,511,514,515,516	41 079 02	34	Bushing, governor (Use before serial no. 1824400002 and after serial no. 1918700002) 503	41 158 02
27	Linkage, throttle (Use after serial no. 1813600002) 249	41 079 02	35	Washer, plain 1/4" 147,164,169,201,211,213,215,217, 220,239,246,248,249,250,251,252, 253,255,257,259,262,263,264,265, 266,267,269,270,271,272,278,280, 281,282,283,285,288,290	X-25-58
27	Linkage, throttle (Use after serial no. 1706400002) 268,500,501,502	41 079 02	36	Shaft, governor cross 147,164,169,201,211,213,215,217 220,239,245,246,248,249,250,251, 252,253,255,257,259,262,263,264, 265,266,267,268,269,270,271,272, 278,280,281,282,283,285,286,288, 290,300,500,501,502,503,504,505, 506,507,508,509,510,511,512,513, 514,515,516	230540-S
27	Linkage, throttle (Use after serial no. 1824400002 but before serial no. 1918700012) 503	41 079 02			
28	Bracket, speed control 220,278,512	41 126 16			
29	Bracket, speed control assembly (Includes 30-33) 201	A-234857			

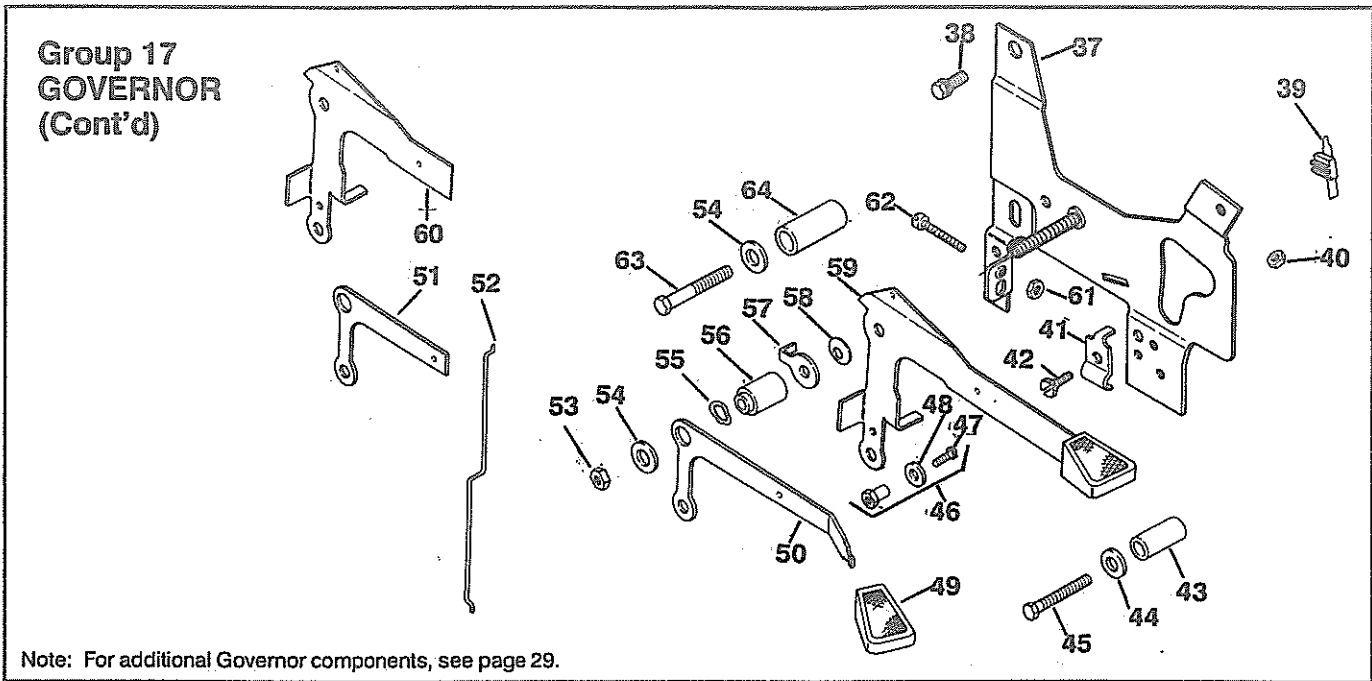

Index Number	Description Variation Number	Part Number	Index Number	Description Variation Number	Part Number
37	Bracket, speed control 211,213,215,217,239,246,248,249, 250,251,252,253,255,257,259,262, 263,264,265,266,267,269,270,271, 272,280,281,282,283,285,288,290, 500,501,502,503,504,505,506,507, 508,509,510,511,513,514,515,516	41 126 40	41	Clamp, bowden wire 213,246,249,259,263,269,271,272, 280,281,283,505,508	235778
38	Screw, H.C. sems 1/4-20x1/2" 211,213,215,217,248,250,259,270, 272,281,500,503,506,507,508,509, 510,513,515	X-132-6	41	Clamp, bowden wire (2) 211,215,217,248,250,252,253,264, 266,267,268,282,285,287,288,500, 501,502,506,507,509,515,516	235778
38	Screw, H.C. sems 1/4-20x1/2" (2) 246,263,271,280,283,505	X-132-6	41	Clamp, bowden wire (Use after serial no. 1813600002) 510	235778
38	Screw, pozidriv truss hd. 1/4-20x7/16" 239,250,251,252,253,257,259,282, 285,288,290,511,514,515	41 086 29	41	Clamp, bowden wire (Before serial no. 181360012 use [2] after serial no. 1813600002 use [1]) 514	235778
38	Screw, pozidriv truss hd. 1/4-20x7/16" (Use after serial no. 1706400002) 249,268,500,501,502	41 086 29	41	Clamp, bowden wire (2) (Use after serial no. 1824400002 but before serial no. 1918700002) 503	235778
39	Switch, kill 211,213,249,250,255,263,265,266, 267,281,282,287,288,504,507,508,515	25 099 12	42	Screw, sltd. hd. 10-24x3/8" 213,246,249,259,263,269,271,272,280 281,283,505,508	X-97-3
39	Switch, kill (Use before serial no. 1823600012) 270	25 099 12	42	Screw, sltd. hd. 10-24x3/8" (2) 211,215,217,248,250,252,253,264,266, 267,268,282,285,287,288,500,501,502, 506,507,509,515,516	X-97-3
39	Switch, kill (Use before serial no. 1824400012) 503	25 099 12	42	Screw, sltd. hd. 10-24x3/8" (Use after serial no. 1813600002) 510	X-97-3
40	Nut, hex. 10-24 211,215,217,248,250,252,253,257, 262,264,267,268,282,285,287,288, 500,501,502,506,507,509,514	X-70-2	42	Screw, sltd. hd. 10-24x3/8" (Use after serial no. 1813600002) 510	X-97-3
40	Nut, hex. 10-24 (Use after serial no. 1824400002 but before serial no. 1918700012) 503	X-70-2	42	Screw, sltd. hd. 10-24x3/8" (Before serial no. 1813600012 use [2] After serial no. 1813600002 use [1]) 514	X-97-3
40	Nut, hex. 10-24 (Use after serial no. 1813600002) 510,513	X-70-2	42	Screw, sltd. hd. 10-24x3/8" (2) (Use after serial no. 1824400002, but before serial no. 1918700012) 503	X-97-3

Index Number	Description Variation Number	Part Number	Index Number	Description Variation Number	Part Number
43	Spacer, T-control bracket 211,213,215,217,218,239,248,249,250, 251,252,253,262,264,265,266,267,268, 270,281,282,283,285,287,288,290,500, 501,502,503,504,506,507,508,509,510, 511,513,514,515,516	41 112 09	51	Lever, choke control 263 Before serial no. 2026900012 use: After serial no. 2026900002 use:	41 090 06 41 090 23
44	Washer, plain #10 211,213,215,217,218,227,239,248,249, 250,251,252,253,262,264,265,266,267, 268,270,281,282,283,285,287,288,290, 500,501,502,503,504,506,507,508,509, 510,511,513,514,515,516	X-25-36	52	Rod, choke link 211,213,215,218,239,248,249,250,251, 252,253,255,257,259,262,263,264,265, 266,267,268,269,270,271,272,280,281, 282,283,285,287,288,290,504,506,507, 508,509,516	41 411 02
45	Screw, hex. hd. 10-24x1-3/8" 211,213,215,217,218,239,248,249,250, 251,252,253,262,264,265,266,267,268, 270,281,282,283,285,287,288,290,500, 501,502,503,504,506,507,508,509,510, 511,513,514,515,516	41 086 16	53	Nut, elastic stop 211,213,215,218,239,246,248,249,250, 251,252,253,255,257,259,262,263,264, 265,266,267,268,269,270,271,272,280, 281,282,283,285,287,288,289,290,500, 501,502,504,506,507,508,509,511,513, 514,515,516	X-101-8
46	Kit, clamp (Includes 47,48) 217,239,246,251,259,263,268,271,272, 280,281,283,288,509,511	48 755 10	54	Washer, plain 1/4" 269,271,280,283,505	X-25-53
46	Kit, clamp (2) (Includes 47,48) 211,215,245,248,249,250,252,253,264, 285,287,500,501,502,510,512,515,516	48 755 10	54	Washer, plain 1/4" (2) 211,213,215,217,218,239,248,249,250, 251,252,253,255,257,262,263,264,265, 266,267,268,270,272,281,282,285,287, 288,290,500,501,502,503,504,506,507, 508,509,511,513,514,515,516	X-25-53
46	Kit, clamp (Includes 47,48) (Use after serial no. 1813600002) 514	48 755 10	55	Washer, wave (1 curve) 211,213,215,217,218,239,246,248,249, 250,251,252,253,255,257,259,262,263, 264,265,266,267,268,269,270,271,272, 280,281,282,283,285,287,288,290,500, 501,502,503,504,505,506,507,508,509, 510,511,513,514,515,516	41 468 03
47	Screw, pan hd. 8-32x1/4" 217,239,246,251,259,263,268,271,272, 280,281,283,288,509,511	X-51-8	56	Spacer, speed control 211,213,215,217,218,239,246,248,249, 250,251,252,253,255,257,259,262,263, 264,265,266,267,268,269,270,271,272, 280,281,282,283,285,287,288,290,500, 501,502,503,504,505,506,507,508,509, 510,511,513,514,515,516	41 112 04
47	Screw, pan hd. 8-32x1/4" (2) 211,215,245,248,249,250,252,253,264, 285,287,500,501,502,510,512,515,516	X-51-8	57	Tab, locking (Replaced by 52 448 02) 211,213,215,217,218,239,246,248,249, 250,251,252,253,255,257,259,262,263, 264,265,266,267,268,269,270,271,272, 280,281,282,283,285,287,288,290,500, 501,502,503,504,505,506,507,508,509, 510,511,513,514,515,516	52 448 01
47	Screw, pan hd. 8-32x1/4" (Use after serial no. 1813600002) 514	X-51-8	58	Washer, wave (2 curves) 211,213,215,217,218,239,246,248,249, 250,251,252,253,255,257,259,262,263, 264,265,266,267,268,269,270,271,272, 280,281,282,283,285,287,288,290,500, 501,502,503,504,505,506,507,508,509, 510,511,513,514,515,516	41 468 04
48	Washer, plain 1/4" 211,215,245,248,249,250,252,253,264, 285,287,500,501,502,510,512,515,516	X-25-102	59	Lever, speed control 211,218,250,253,255,264,266,267,268, 270,282,283,285,500,501,504,506,507, 510,515,516	41 090 17
48	Washer, plain 1/4" (2) 217,239,246,251,259,263,268,271,272, 280,281,283,288,509,511	X-25-102	59	Lever, speed control (Use before serial no. 1706400012 and after serial no. 1813600002) 249	41 090 17
48	Washer, plain 1/4" (Use after serial no. 1813600002) 514	X-25-102	59	Lever, speed control (Use after serial no. 1824400002, but before serial no. 1918700012) 503	41 090 17
49	Knob 213,215,239,251,252,257,259,263,264, 268,271,272,280,281,283,287,288,290, 502,505,508,510,511,513,514	41 341 03	60	Lever, speed control 213,215,217,246,248,251,252,257,259, 262,263,265,269,271,272,280,281,287, 288,290,502,505,508,509,511,514	41 090 18
49	Knob (2) 211,218,249,250,253,255,266,270, 285,500,501,503,504,506,507	41 341 03			
49	Knob (Use before serial no. 1813600002) 282,516	41 341 03			
49	Knob (2) (Use after serial no. 1813600012) 282,516	41 341 03			
50	Lever, choke control 211,213,215,218,239,249,250,251,252, 253,255,257,259,264,265,266,267,268, 269,270,271,272,280,281,282,283,285, 287,288,290,504,506,507,508,516	41 090 06			
50	Lever,choke control 217	41 090 11			

Index Number	Description Variation Number	Part Number	Index Number	Description Variation Number	Part Number
60	Lever, speed control (Use after serial no. 1706400002 but before serial no. 1813600012) 249	41 090 18	64	Spacer, handle bracket 211,213,215,217,218,239,248,249,250, 251,252,253,255,257,262,264,265,266, 267,268,270,272,281,282,283,285,287, 288,290,500,501,502,503,504,505,506, 507,508,509,510,511,513,514,515,516	41 112 08
60	Lever, speed control (Use after serial no. 1824400002 but before serial no. 1918700012) 503	41 090 18	NOT ILLUSTRATED		
61	Nut, hex. 8-32 211,213,215,217,218,239,246,248,249, 250,251,252,253,255,257,259,262,263, 264,265,266,267,268,269,270,271,272, 280,281,282,283,285,287,288,290,500, 501,502,503,504,505,506,507,508,509, 510,511,513,514,515,516	X-72-4		Decal, choke, white 211,213,215,218,249,250,251,252,523, 259,261,263,264,265,266,267,268,269, 270,272,280,281,282,283,287,288,290	41 113 08
62	Screw, sltd. hd. 8-32x1" 211,213,215,217,218,239,246,248,249, 250,251,252,253,255,257,259,262,263, 264,265,266,267,268,269,270,271,272, 280,281,282,283,285,287,288,290,500, 501,502,503,504,505,506,507,508,509, 510,511,513,514,515,516	41 086 12		Decal, choke, black 257,271,514	41 113 09
63	Screw, hex. mach. 1/4-20x1-7/8" 211,213,215,217,218,239,248,249,250, 251,252,253,255,257,262,264,265,266, 267,268,270,272,281,282,283,285,287, 288,290,500,501,502,503,504,505,506, 507,508,509,510,511,513,514,515,516	41 086 17		Decal, choke, black (Use after serial no. 1813600002) 255	41 113 09
				Decal, speed control, white 211,218,266,267,270,282,500,507	41 113 06
				Decal, speed control, white (Use before serial no. 1706400012 and after serial no. 1813600002) 500	41 113 08
				Decal, speed control, white 253,264,283,501,506	41 113 13

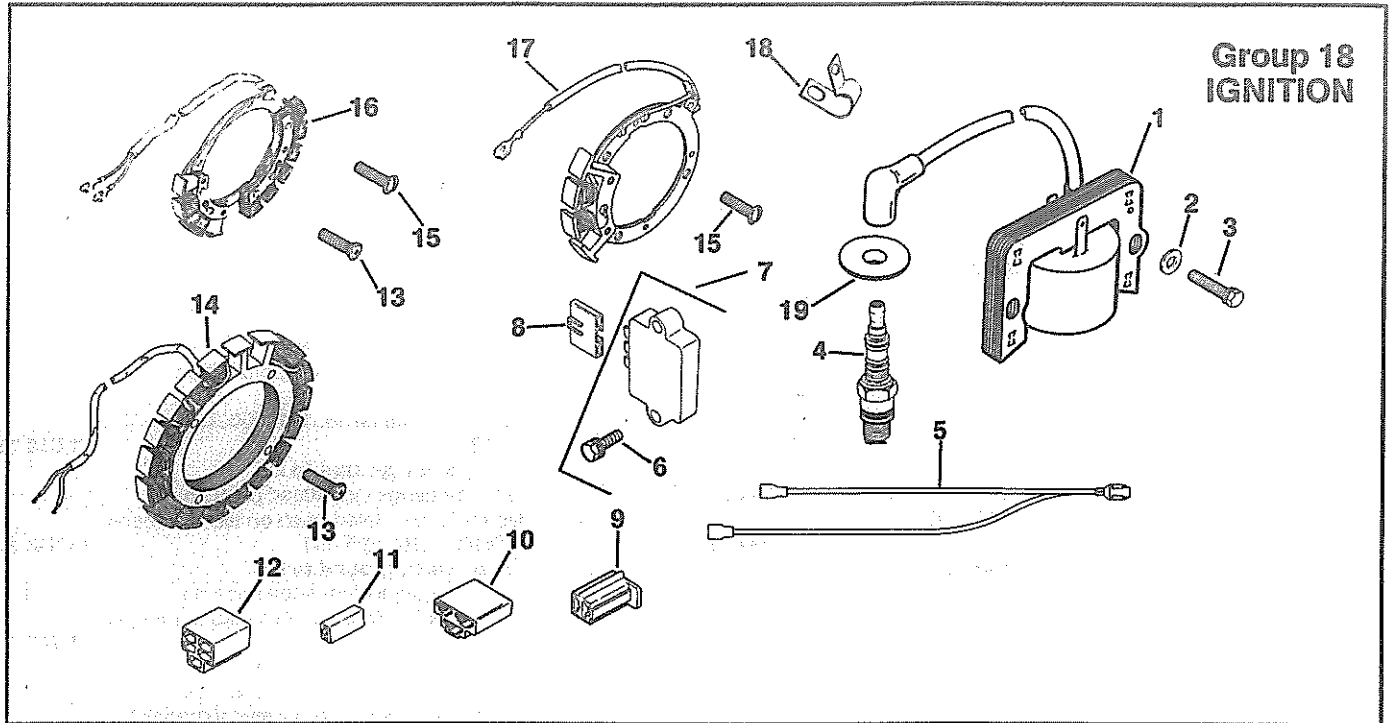

**Group 18
IGNITION**

Index Number	Description Variation Number	Part Number	Index Number	Description Variation Number	Part Number
1	Module, ignition 260,264,265,267,268,269,272,274,275, 279,280,281,283,287,288,289,290,291, 292,294,295,297,298,299,300,301,302, 590,593	41 584 02	5	Wiring harness (Use before serial no. 1905200012) 288	41 176 07
2	Washer, plain #10 (2) 260,264,265,267,268,269,272,274,275, 279,280,281,283,287,288,289,290,291, 292,294,295,297,298,299,300,301,302, 590,593	X-25-79	5	Wiring harness, key switch and remote kill (Use after serial no. 1919300002) 294	41 176 08
3	Screw, H.C. sems 10-24x7/8" (2) 260,264,265,267,268,269,272,274,275, 279,280,281,283,287,288,289,290,291, 292,295,297,298,299,300,301,302,590, 593	X-156-1	5	Wiring harness 275 Before serial no. 1601600012 use: After serial no. 1601600002 use:	41 176 03 41 176 06
4	Spark plug 260,264,265,267,268,269,272,274,275, 279,280,281,287,288,289,290,291,292, 297,298,299,300,301,302,590,593	41 132 02	5	Wiring harness 290	41 176 01
4	Spark plug 283 Before serial no. 1721100012 use: After serial no. 1721100002 use:	41 132 02 41 132 06	5	Wiring harness 295 (Use before serial no. 1910800012)	41 176 11
4	Spark plug 295 Before serial no. 2000200012 use: After serial no. 2000200002 use:	41 132 02 25 132 02	5	Wiring harness 299 (Use after serial no. 2028400002)	41 176 06
5	Wiring harness 267,280	41 176 03	5	Wiring harness (Use after serial no. 1919300002) 593	41 176 09
5	Wiring harness 272,297,299	41 176 06	5	Wiring harness (Use after serial no. 2028400002) 590	41 176 09
5	Wiring, harness (Use before serial no. 1905200012) 287	41 176 06	6	Screw, H.C. sems 1/4-20x1" (2) (Use with rectifier-regulator marked 41 403 05) 265,274,288,289	X-132-4
5	Wiring, harness (Use before serial no. 2033300012) 300	41 176 04	6	Screw, H.C. sems 1/4-20x5/8" (2) (Use with rectifier-regulator marked 41 403 09) 265,274,288,289,292,294,295,301	X-132-5
5	Wiring, harness 279	41 176 04	7	Kit, rectifier-regulator (Includes 6) 265,274,288,289,292,294,295,301	25 755 03
			8	Connector, female (3 contact) 265,274,288,289,292,294,295,301	236602

**IGNITION
(Con'd)**

M8

Index Number	Description Variation Number	Part Number	Index Number	Description Variation Number	Part Number
9	Connector, female (2 contact) 267,269,274,280,289,299	41 155 03		Lead, black, oil sentry to connector to oil light	
10	Connector, female (3 contact) 264	236473		(24" - 18 gauge - insulated push on tab - uninsulated push on tab terminals)	
11	Connector, female (1 contact) 275,298	277563		300	41 518 41
11	Connector, female (1 contact) (Use after serial no. 2033300002) 300	277563		Lead, white, kill switch (16" - 18" gauge - insulated push on tab terminals) (Use before serial no. 2028400012)	
12	Connector, female (5 contact) 265,274,288,294,295	48 155 01		590	41 518 25
13	Screw, hex. hd. 10-24x3/4" (4) 265,274,288,289,301,292,294,295,301	X-67-51		Lead, white kill switch (16" - 18" gauge - insulated push on tab terminals) (Use before serial no. 1919200012)	
13	Screw, hex. hd. 10-24x3/4" 264	X-67-51		593	41 518 25
14	Stator, 15 amp 265,274,288,289,292,294,295,301	41 085 07		Lead, white, ground to kill (21" - 18 gauge - insulated push on tab and uninsulated push on tab terminals)	
15	Screw, tapping 10-24x3/8" (4) 264,299	25 086 30		269,274,289,295,301	41 518 37
15	Screw, tapping 10-24x3/8" (3) 267,269,280	25 086 30		Lead, white, ground to kill (21" - 18 gauge - insulated push on tab and uninsulated push on tab terminals)	
16	Stator, 1.5 amp 264	25 085 03		288	41 176 07
17	Stator, 1.5 amp 267,269,280,299	25 085 01		Lead, white, ground to kill (21" - 18 gauge - insulated push on tab and insulated barrel eyelet terminals) (Use before serial no. 1905200012)	
18	Clip 260,264,265,267,268,269,272,274,275, 279,280,281,283,286,287,288,289,290, 291,292,295,297,298,299,300,301,302	210281		287	41 518 35
18	Clip (Use after serial no. 2000200002) 295	210281		Lead, white, ground to kill (21" - 18 gauge - insulated push on tab and uninsulated push on tab terminals) (Use before serial no. 2028400012)	
18	Clip (2) (Use before serial no. 2000200012) 295	210281		299	41 518 37
19	Grommet, spark plug 297	47 313 01		Lead, red, connector to ground (4" - 18 gauge - uninsulated male bullet, insulated grip barrel eyelet terminals)	
	NOT ILLUSTRATED			281	47 518 51
	Lead, violet (12-1/2" - 14 gauge - locking tang female 1/4") 289	41 518 46		Lead, violet, rectifier to connector (15" - 14 gauge - uninsulated push on tab terminals) 274,292,295	41 518 27
	Lead, white, ground to kill switch (10" - 18 gauge - insulated push on tab - insulated grip barrel eyelet terminals) 281	25 518 16		Lead, violet, key switch to rectifier regulator (19" - 14 gauge - uninsulated push on tab terminals)	
	Lead, black, starter to solenoid (4" - 6 gauge - insulated barrel eyelet terminals) 265,294,301	41 518 19		265,288,294,301	41 518 29
	Lead, light blue, key switch to solenoid (6" - 18 gauge - uninsulated push on tab and insulated push on tab terminals) 265,288,294	41 518 20		Lead, fuse holder 265,288,294	41 323 03
	Lead, white, kill switch (16" - 18 gauge - insulated push on tab terminals) 283,291,292	41 518 25		Lead, white, ground to kill (21" - 18 gauge - insulated push on tab and insulated barrel eyelet terminals) 272,302	41 518 35
				Lead, white, w/diode, ground to kill (23-1/2" 18 gauge - insulated push on tab and uninsulated push on tab terminals) 264	41 518 38

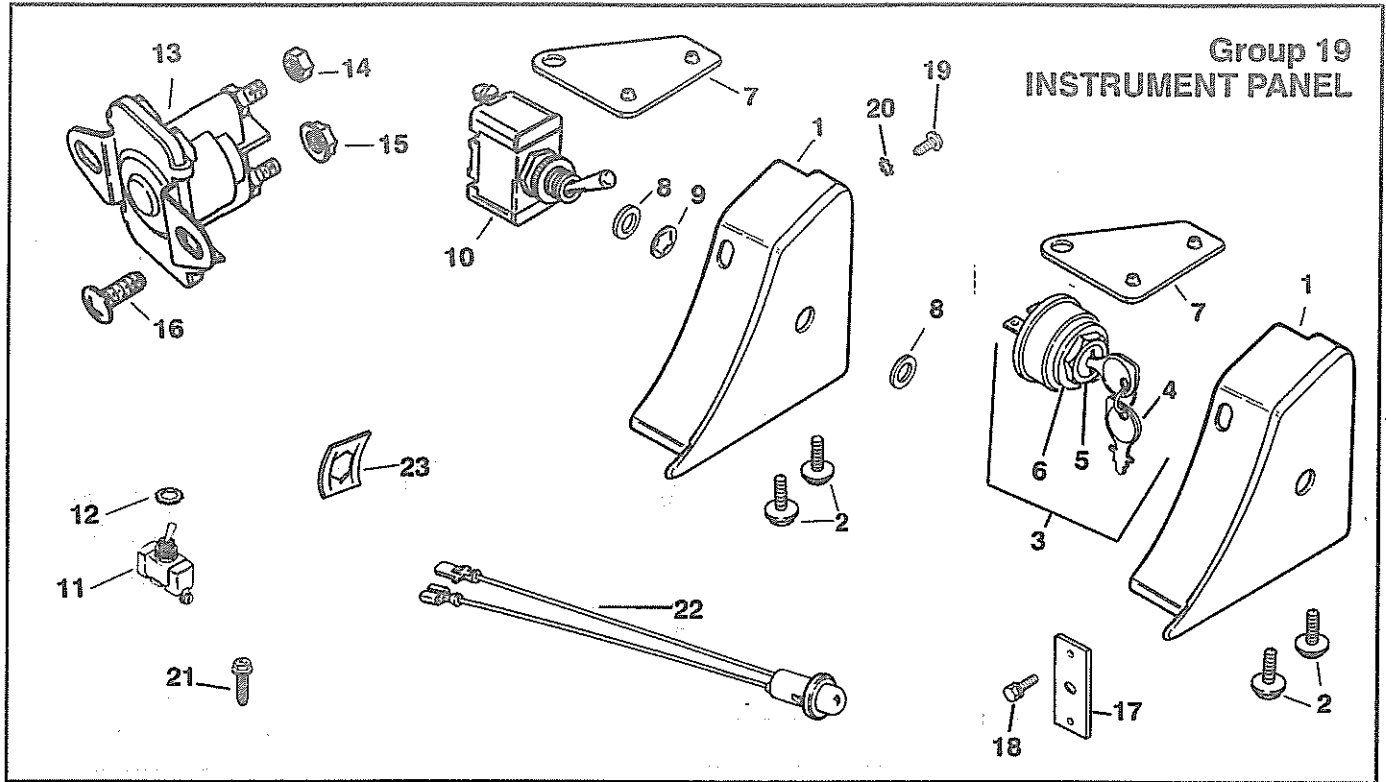

**Group 19
INSTRUMENT PANEL**

Index Number	Description Variation Number	Part Number	Index Number	Description Variation Number	Part Number
1	Panel, instrument 56,58,61,66	41 178 04	18	Screw, truss hd. 1/4-20x5/8"	47 086 08
1	Panel, instrument 65	41 378 07	19	Screw, self tap 1/4-20x5/8"	52 086 11
2	Screw, hex. hd. 10-32x1/2" (2) 56,58,61,65,66	X-806-1	20	Washer, shake proof 56,58,61,65,66	X-22-12
3	Switch, key assembly (Includes 4,5,6) 56	25 099 04	21	Screw, hex. cap 1/4-20x1/2" (Used with lead 25 518 17) 64	X-5-13
4	Key (set of 2) 56	48 340 01	22	Light assembly, indicator 65	25 352 01
5	Nut 56	48 100 01	23	Nut, speed 65	25 100 03
6	Washer 56	48 468 02	NOT ILLUSTRATED		
7	Bracket, panel 56,58,61,65,66	41 126 27		Lead, white, ground to switch (12" - 18 gauge - insulated grip barrel eyelet terminals) 59,64	25 518 17
8	Washer, plain 7/16" (2) 58,61	X-25-34		Lead, black starter to solenoid (4" - 6 gauge - insulated barrel eyelet terminals) 57	41 518 19
9	Washer, I.T./E.T. 1/2" 58,61	X-22-26		Lead, green, ground (5" - 18 gauge - insulated barrel eyelet and uninsulated push on tab terminals) 56,66	41 518 31
10	Switch, toggle 58,61	151510		Lead, green, ground (5" - 18 gauge - insulated barrel eyelet terminals) 58,61	41 518 34
11	Switch, toggle 59,64	238011		Lead, red, switch to connector (14" - 18 gauge - uninsulated male bullet, insulated grip barrel eyelet terminals) 59,64	47 518 50
12	Nut, knurled 59,64	41 100 06		Decal, ignition 56,66,502	41 113 12
13	Solenoid (Replaced by 25 435 01) 57	52 435 01		Decal, ON-OFF 58	41 113 18
14	Nut, hex. 1/4-20 57	X-81-1			
15	Palnut, 1/4-20 (3) 57	X-799-1			
16	Boft, R.H. sq. neck 1/4-20x9/16" (2) 57	52 086 10			
17	Cover, regulator plate 59	25 096 01			

**Group 21
OIL PAN**

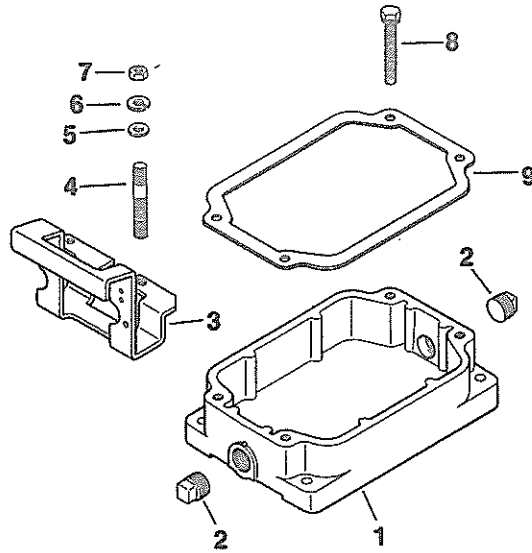

Index Number	Description Variation Number	Part Number	Index Number	Description Variation Number	Part Number
1	Pan, oil (Double drain) 91	41 199 11	5	Washer, plain 5/16" (2) 523	X-25-44
1	Pan, oil (Rear drain) 94	41 199 10	6	Washer, lock 5/16" (2) 91,98,99	X-21-1
1	Pan, oil (Single drain opposite carburetor) 1,98	41 199 07	6	Washer, lock 5/16" (2) (Use before serial no. 1731200012) 523	X-21-1
1	Pan, oil (Double drain) 23,99,100,101,523	41 199 06	7	Nut, hex. 5/16-18" (2) 91,98,99,100	X-82-2
2	Plug, sq. hd. 1/2 N.P.T.F. (2) 91,99,523	X-75-28	7	Nut, hex. 5/16-18" (2) (Use before serial no. 1731200012) 523	X-82-2
2	Plug, sq. hd. 1/2 N.P.T.F. 1,94,98,100,101	X-75-28	8	Screw, H.C. 5/16-18x1-3/8" (2) 91,98,99,100	41 086 15
3	Bracket, handle 91,98,99,100	41 126 21	8	Screw, H.C. 5/16-18x1-1/8" (4) 23,94,101	X-154-3
4	Stud 5/16-18x2" (2) 91,98,99,100	41 072 18	8	Screw, H.C. 5/16-18x1-3/8" (2) (Use before serial no. 1731200012) 523	41 086 15
4	Stud 5/16-18x2" (2) (Use before serial no. 1731200012) 523	41 072 18	8	Screw, H.C. 5/16-18x1-1/8" (4) (Use after serial no. 1731200002) 523	X-154-3
5	Washer, plain 5/16" (2) 91,98,99,100	X-25-44	9	Gasket, oil pan 1,23,91,94,98,99,101,523	41 041 03

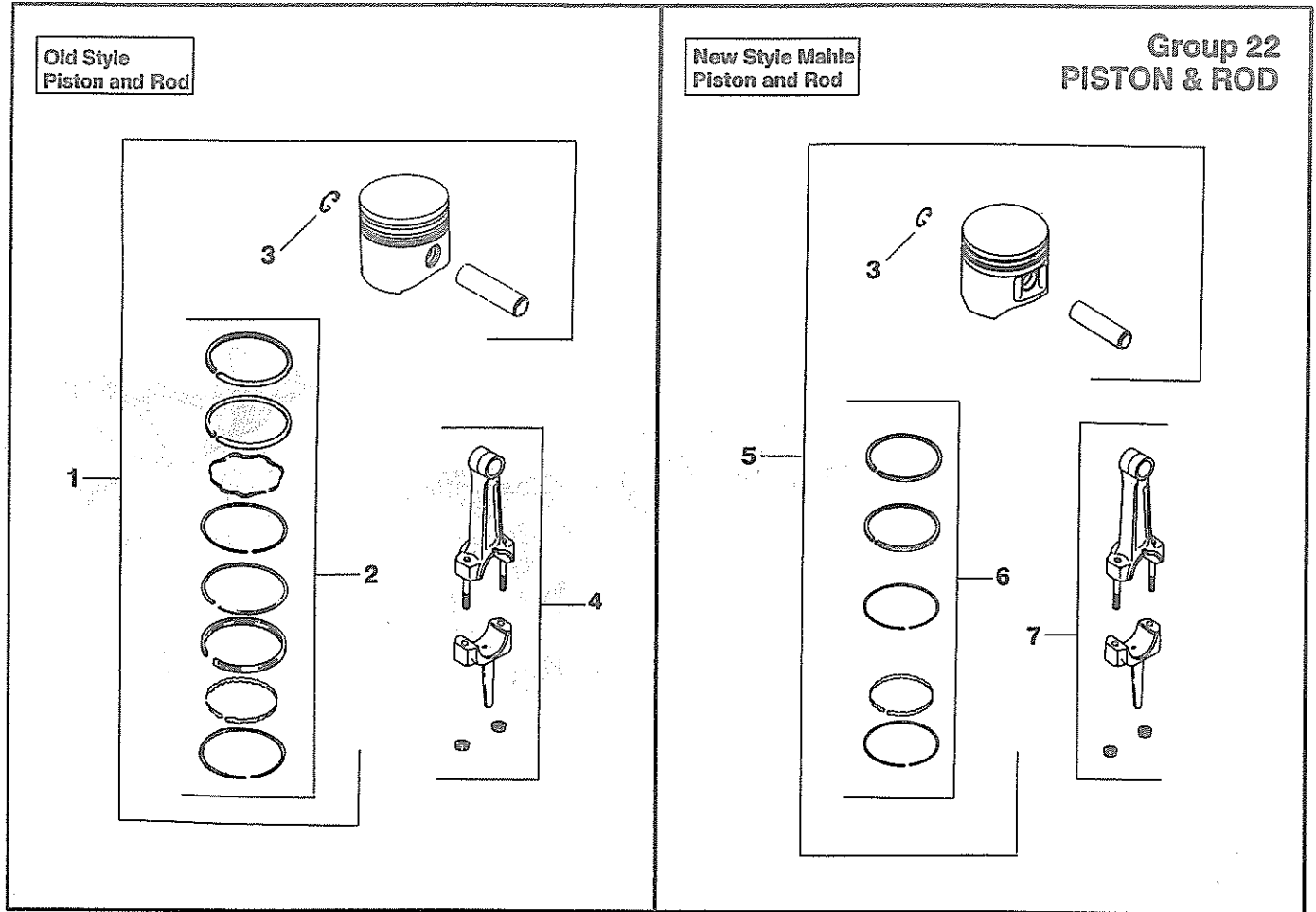

Index Number	Description Variation Number	Part Number	Index Number	Description Variation Number	Part Number
OLD STYLE PISTON DESIGN			NEW STYLE MAHLE PISTON DESIGN		
1	Ring set - standard & .003 500	232575	5	Ring set - standard & .003 16,500	41 108 01
1	Ring set - .010 500	232576	5	Ring set - .010 16,500	41 108 02
1	Ring set - .020 500	232577	5	Ring set - .020 16,500	41 108 03
1	Ring set - .030 500	232578	5	Ring set - .030 16,500	41 108 04
2	Piston with ring set - standard 500	41 874 05	6	Piston with ring set - standard 16,500	41 874 10
2	Piston with ring set - .003 500	41 874 06	6	Piston with ring set - .003 16,500	41 874 11
2	Piston with ring set - .010 500	41 874 07	6	Piston with ring set - .010 16,500	41 874 12
2	Piston with ring set - .020 500	41 874 08	6	Piston with ring set - .020 16,500	41 874 13
2	Piston with ring set - .030 500	41 874 09	6	Piston with ring set - .030 16,500	41 874 14
3	Piston pin retainer (2) 16,500	230004	7	Connecting rod - standard 16,500	41 067 08
4	Connecting rod - standard 500	41 067 10	7	Connecting rod - .010 16,500	41 067 09
4	Connecting rod - .01 500	41 067 11			

Note: Order parts according to style used on engine.

**Group 23
RETRACTABLE STARTER**

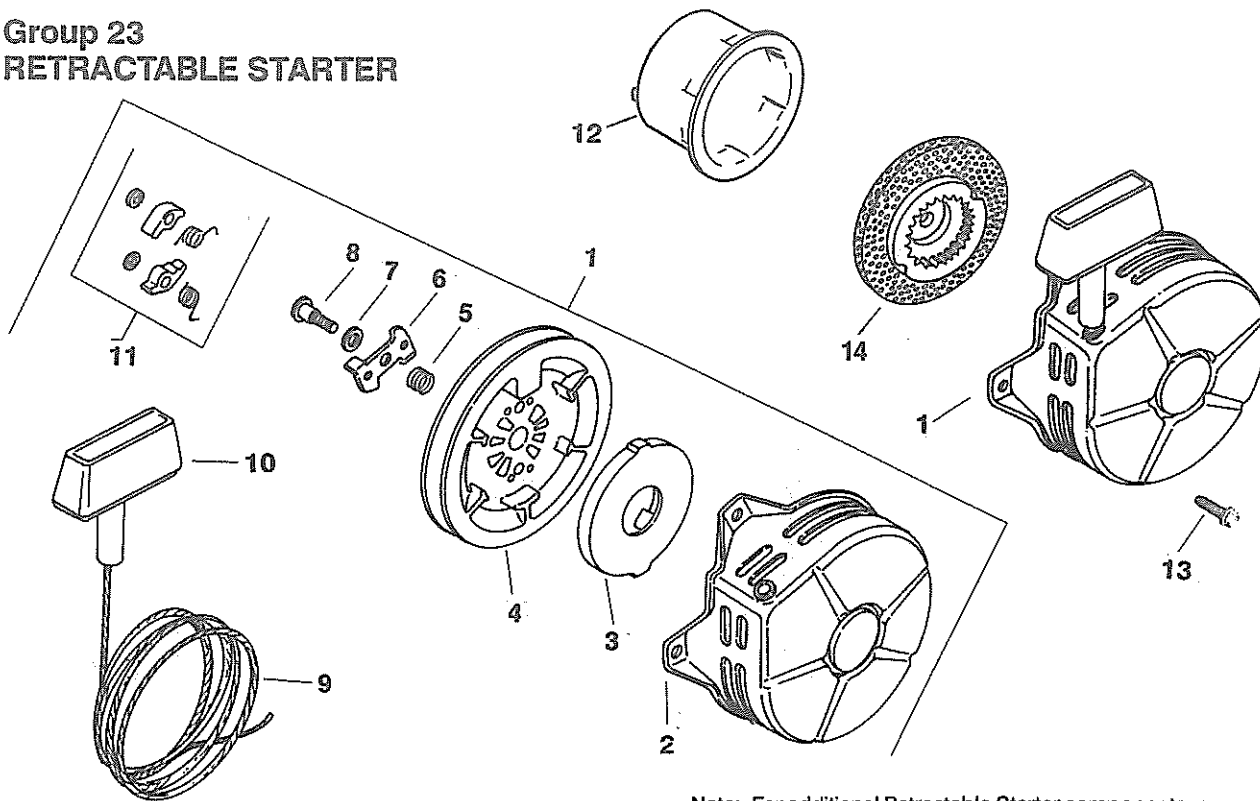

Note: For additional Retractable Starter components, see page 41.

Index Number	Description Variation Number	Part Number	Index Number	Description Variation Number	Part Number
<p>Note: When ordering replacement parts, refer to illustrations on pages 40-41, to determine which starter breakdown to follow.</p>					
1	Assembly, retractable starter (Includes 2-11) (Used before serial no. 1802800012) (Replaced by kit 41 755 26) (Serviceable components are available, see index numbers 2-11.)	41 165 04	7	Washer 527,532	41 468 02
2	Housing 527,532	41 095 08	8	Screw 527,532	41 086 09
3	Spring & keeper assembly 527,532	41089 07	9	Rope, starting (Replaced by 15 160 01) 527,532	41 160 01
4	Pulley 527,532	41 093 05	10	Handle 527,532	234452
5	Spring 527,532	41 089 09	11	Kit, pawl repair 527,532	41 757 02
6	Cam, dog 527,532	41 149 01	12	Cup, drive (Use before serial no. 1802800012) 527	41 109 03
			13	Screw, F.H.M. 10-24x1/4" (5) 9,33,527,532	41 068 06
			14	Cup and screen assembly (Used before serial no. 1802800012) 532	41 109 06

**Group 23
RETRACTABLE STARTER
(Cont'd)**

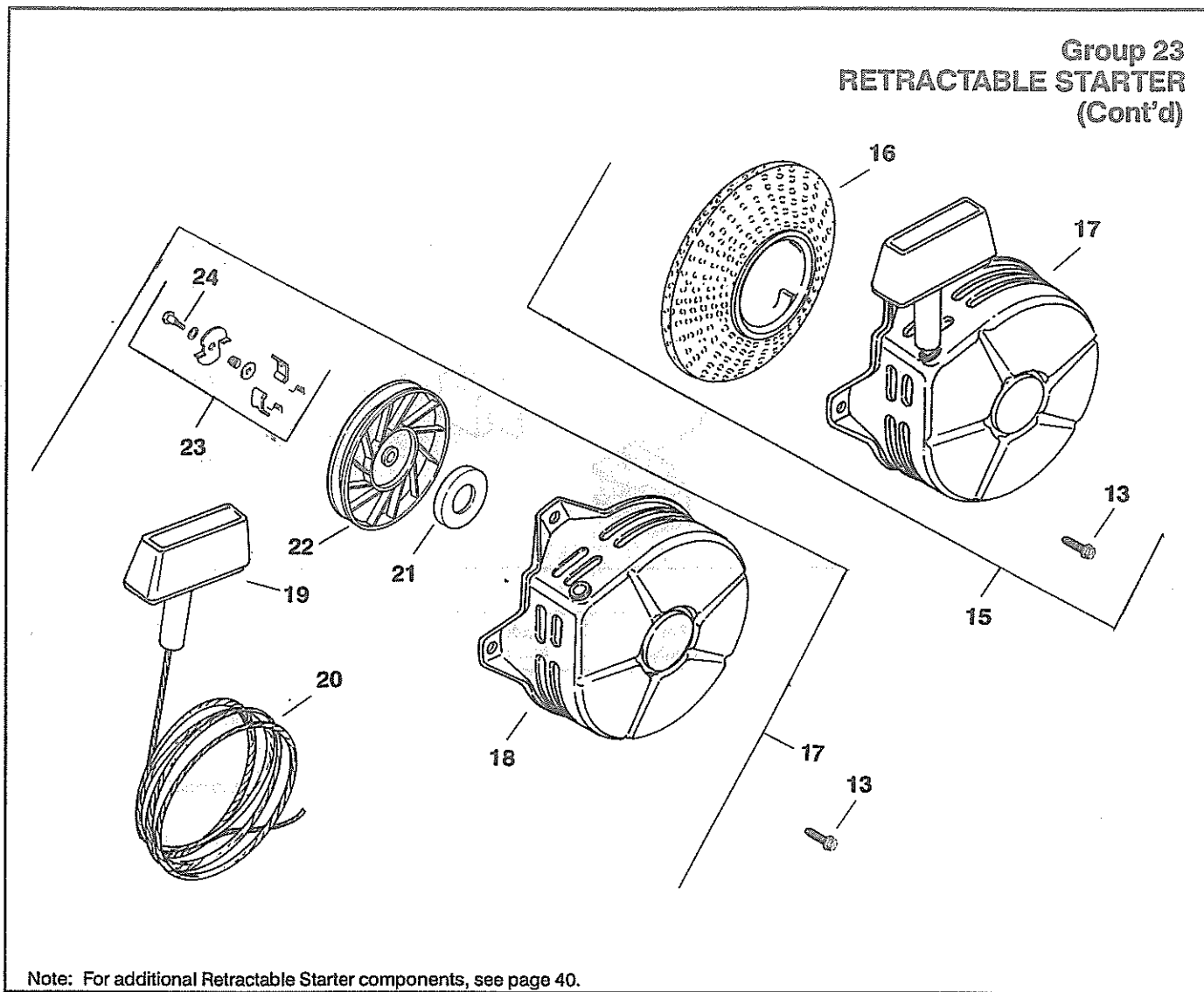

Note: For additional Retractable Starter components, see page 40.

Index Number	Description Variation Number	Part Number	Index Number	Description Variation Number	Part Number
15	Kit, retractable starter assembly (Includes 13,15,17) (Used before serial no. 1802800012) 527,532	41 755 26	18	Housing 9,33,527,532	41 081 04
16	Cup and screen assembly 9,33	41 071 07	19	Handle, recoil starter 9,33,527,532	41 166 01
16	Cup and screen assembly (Used after serial no. 1802800002) 527,532	41 071 07	20	Rope 9,33,527,532	15 160 01
17	Starter, retractable assembly (Includes 18-24) 9,33	41 165 06	21	Spring and keeper 9,33,527,532	12 089 06
17	Starter, retractable assembly (Includes 18-24) (Used after serial no. 1802800002) 527,532	41 165 06	22	Pulley 9,33,527,532	41 093 10
			23	Kit, pawl (dog) repair 9,33,527,532	41 757 07
			24	Screw, pozidriv 9,33,527,532	41 086 09

**Group 32
OIL LEVEL CUTOUT**

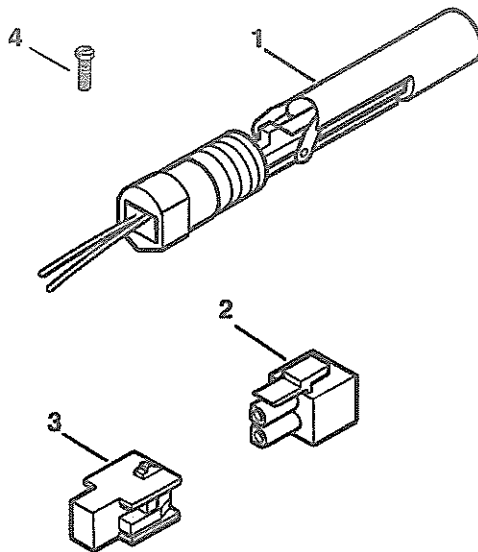

Index Number	Description Variation Number	Part Number	Index Number	Description Variation Number	Part Number
1	Kit, oil level switch (Includes decal 25 113 05, terminals: 25 431 02, 25 452 03, 25 452 07) 1,2,3,8	25 704 03		Terminal (Ring tongue insulated grip) 1,2,3,6,8	25 452 03
1	Kit, oil level switch (Includes decal 25 113 05, terminals: 25 452 01, 25 452 02, 25 452 03, 25 431 03) 6	25 704 04		Terminal (Uninsulated locking tang, female push on tab 1/4") 1,2,3,8	25 452 07
2	Connector, receptacle 8	47 155 13		Terminal (2) (Uninsulated locking tongue, female push on tab 1/4") 6	25 452 01
3	Connector, plug 8	47 155 14		Terminal (Ring tongue insulated grip) 6	25 452 02
4	Screw, sems hex. hd. 1/4-20x1/2" (To ground switch) 6	X-132-6		Sleeving 1,2,3,8	25 431 02
	NOT ILLUSTRATED Decal, oil sentry 1,2,3,6,8	25 113 05		Sleeving 6	25 431 03

Description	Part Number	Description	Part Number
GASKET SET (with seals)	41 755 17	GASKET SET (withoutseals)	41 004 05
Set includes:		Set includes:	
Seal, front oil	X-583-1	Gasket, air cleaner	AC-1787
Seal, rear oil	X-583-2	Gasket, flange	210223
Gasket, air cleaner	AC-1787	Gasket, air horn	41 041 11
Gasket, flange	210223	Seal, breather	230046
Gasket, air horn	41 041 11	Gasket, valve cover (2)	230048
Seal, breather	230046	Gasket, exhaust	41 041 01
Gasket, valve cover (2)	230048	Gasket, oil pan	41 041 03
Gasket, exhaust	41 041 01	Gasket, air cleaner	41 041 04
Gasket, oil pan	41 041 03	Gasket, bearing plate	41 041 07
Gasket, air cleaner	41 041 04	Gasket, bearing plate shim (5)	41 041 08
Gasket, bearing plate	41 041 07	Gasket, cylinder head	41 041 10
Gasket, bearing plate shim (5)	41 041 08	Gasket, fuel pump	52 041 17
Gasket, cylinder head	41 041 10	Gasket, fuel pump	25 041 05
Gasket, fuel pump	52 041 17	Cup plug	52 139 09
Gasket, fuel pump	25 041 05		
Cup plug	52 139 09		

THE NEW SHAPE OF KOHLER POWER

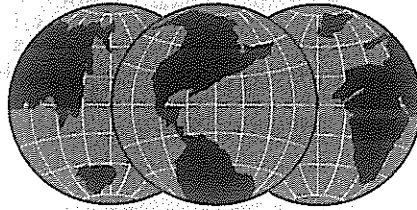

KOHLERengines

ENGINE DIVISION, KOHLER CO., KOHLER, WISCONSIN 53044

FOR SALES AND SERVICE INFORMATION
IN U.S. AND CANADA, CALL
1-800-544-2444

FORM NO.:	TP-2201-C
ISSUED:	3/86
REVISED:	5/92
MAILED:	8/92

LITHO IN U.S.A.